

# Merkur Knowledge Base



Version 2.15

Distribution started December 20, 2006

A compilation of Information from Merkur Enthusiasts  
Worldwide

Edited by Richard Thompson  
Of MerkurXR4Ti.com

Note: Information included herein can be considered merely a guide and is for reference only. Do not attempt any repair or modification for which you do not have the confidence and skills to complete. Neither the Editor nor any authors can be held responsible for the use or misuse of any information within this document. This collection of information cannot be sold, resold, traded, or modified. If you paid anything for this, you were cheated and should get your money back!

[Buying a Merkur](#)  
[Upgrade Path](#)  
[Safety](#)  
[Intake Side](#)  
[Turbocharger](#)  
[Engine](#)  
[Dual Plug Head](#)  
[Car Won't Start](#)  
[Troubleshooting](#)  
[Fuel System](#)  
[Cooling System](#)  
[Body](#)  
[Steering](#)  
[Interior](#)  
[Air Conditioning](#)  
[Suspension](#)  
[Differential & CV Joints](#)  
[Driveshaft and Guibo](#)  
[Wheels and Tires](#)  
[Transmissions and Clutch](#)  
[Transmission Conversions](#)  
[Automatic Transmission](#)  
[Brakes and Upgrades](#)  
[Heating](#)  
[EEC-IV Codes](#)  
[Ignition and Computer](#)  
[Electrical](#)  
[Body – Electrical](#)  
[Sensors](#)  
[Exhaust System](#)  
[Scorpio Stuff](#)  
[Sound System](#)  
[Parts Sources](#)  
[Junkyard Strategy](#)  
[Miscellaneous](#)  
[Merkur Miscellany](#)  
[Index](#)

## Air Conditioning

---

- **3-way switch** Dave Shipley posted about the three way switch. Get either a Frigette 211-176 or Four Season 35922 three way switch from a truck shop or some parts store which sells truck parts. These switches will work in either XR4 or Scorpio. Costs around 35.00. What about BAT? Rapido? The de-icer switch is in the cramped area behind the "first firewall" behind the battery. The unit is mounted with two screws, and the unit's sensor protrudes into the evaporator housing, pointing towards the driver's side, held in place with a grommet. Not too bad to get out, but tough to get back in with big hands. It is located next/near to the air circulation door actuator. Hope this helps! A in K
- Manuel Garriga asks where to obtain a 3-way pressure switch. B.A.T. wants \$105 for one. I purchased one for my Scorpio from Vintage Air in San Antonio Tx. Cost \$35.99 plus shipping. Perfect match. You have to cut the wire harness off the old switch and connect to the new switch. No problem if you have a wiring diagram. Vintage Air calls it an F-male trinary switch P/N 11076-VUS. Their phone is 210-654-7171. Bill

---

- Air-Conditioning Supply that deals in Merks by Jim McQueen  
Hancock Industries, Abilene TX  
[www.hancockindustries.com](http://www.hancockindustries.com)  
(800)289-8282, (325)692-9290

---

- Online \$10 Certification to buy Freon  
The name of the website is called <http://www.epatest.com> and offers a \$10 certification test for Section 609 of the EPA regulations that permits the purchase of Freon.

---

- Source for rebuilt longer air-conditioning hoses by Al Lawler and Bob McGlone  
I got a "new" (very nicely rebuilt) hose a few years back from a guy named Warren at AAPK out in Arizona. The hose was longer than the old one (so it could be routed around the fenderwell instead of over the turbo. Price was around \$216 (that included a pretty hefty core-charge of \$100, which was then returned when you sent him your old one.) Can't beat it for \$116.

AAPAK (Automotive Air Parts and Kits )  
Warren Willingham  
1845 N.W. Grand  
Phoenix, Arizona 85007  
(602)254-1116  
1-800-832-5544

---

- Freon Capacity of Merkur XR4Ti by Jim McQueen  
**Q:** Does someone know the amount of R-12 to fill the XR system? I have lost my spec sheet and need to get the info. back. Ounces or pounds is fine., Thanks Ian.  
**A:** 1 pound 12 ounces. Note, if your replacing with R134a my A/C guy put in @ 1 pound of R134a in due to the higher pressures.

---

- What kind of compressor does the XR utilize by Dimitri Wittal & Ken Kiser  
**Q:** Exactly what make/model IS the compressor on the XR's??  
**A:** our cars use a variant of one of the most popular compressors around. We use a Nippondenso 10P17E, which differs only in the case from the 10P17C, a hugely popular compressor. The E uses mounting ears and the C mounts directly to the engine bracket. The 2.3 mustang after 1990 uses the 10P17C, so the bracket to use that model is available and the cost of the C version is about 1/3 lower than the E. You'd need to switch to serpentine belts or figure out a way to tension a V belt if you use a compressor without ears.  
**From Ken Kiser:** Faced with need for a compressor, I figured it was easier to build brackets for a newish one off a late 80's Toyota something, like a Corolla (not the Camry, and not sporty). Same case style (for the hose manifold), same clutch (no belt/pulley weirdness). Why not just replicate the ears? A few pieces of angle iron, an arc welder... I had to trim the compressor mounting bosses a bit, but it fits like the original (or should, when it's mounted). I used a spare Scorpio a/c

bracket as the template. (By the way, did you know the 88 and 89 Scorpio brackets are different?)  
Hoses mount the same, clutch \_is\_ the same... Pump a vacuum, two cans of 134, and yer cool.

- Air-Conditioning System Operational Restoration by Joshua Lawrence

I did this last summer on my '89 XR, and am happy with the results. I will also be doing it again this summer on 2 88's. As a brief summary, here is what I would recommend:

Get a new hose set, Replace the expansion valve, and replace the receiver/drier.

Clean out the system THOROUGHLY, replace ALL "o" rings, and install the new parts. Vacuum the system down and check for leaks, if none are found you are ready to go! Charge up the system, and hopefully you are set.

As far as the electrical system goes, should the compressor fail to engage, there are two likely points of failure, the 3-way pressure switch (located on top of the receiver/drier) and the de-icer switch (located on the side of the blower case). If either of these are faulty, (and they often are it seems) the system will not engage.

At a minimum, I think you could get by for around \$200-\$250 if you plan on buying the parts and doing all the work yourself, but of course that depends on how successful (creative?) you are at finding good deals on parts. Rapido should have the parts you need, the receiver/drier is \$166 and the hose set is \$187. You might be able to get them from BAT as well, but they didn't have them in stock when I called. You can get the expansion valve from carparts.com, it is fairly inexpensive.

Personally, I hated to pay that much for parts, so I had a shop in the Chicago area specializing in hydraulic hoses repair mine. Of course, I made sure they made them long enough to go around the strut tower rather than directly over the turbo. It was \$85 to have this done.

I took my old receiver/drier, and cut the end off along the weld with a cut-off tool. Emptied out the contents, sand blasted it, cleaned, repainted (outside only), repacked it with new desiccant, had a friend TIG weld the end back on. I got the new desiccant from an A/C & refrigerant shop I found over the net. This desiccant was like \$10.

Personally, I refilled the system with Duracool rather than R12. I am happy with the results, I have vent temps in the low to mid 30s although sitting at an idle it is warmer.

- Air-Conditioning System Operational Restoration additional comments by Don  
I have just restored A/C in three XR's. Two with R-12 and one with R-414B. First you will need to remove the line set that attaches to the compressor at both ends. Then send it to Gary Weaver and ask him to make the top line 47 inches long and the bottom line the original length. He will know exactly what you are talking about. Clean these lines out perfectly with compressed air and then refrigerant oil. It must be perfectly clean. He charges \$120 if you ship it to him, \$80 if you bring it there and wait while he makes the line set. You can also get the high pressure line redone with R-134A compatible hose. I haven't because if the system lets the refrigerant leak then all you have to do is add another 22 bucks worth of R-414B and get that hose made when that happens. It will probably take three years to leak out if you run it 15 minutes every Monday. Get all the O-rings for the whole system, seven in all. Get R-134A compatible O-rings. Find someone near you who sells Hot-Shot, R-414B or go to their web site. It will cost about 12 dollars per pound. You will need 32 ounces for an XR. The R-414B cools better at low speed or idling than R-134A in our systems. Here is the tricky part. If the system was empty you need to either replace or verify the operation of all the components. Look inside the compressor. It should be perfectly clean. Its so difficult to check parts that the simplest solution is just do the conversion and see if it works. If it doesn't work then have them suck out the freon and then replace the bad part. Your high side should be about 300 PSI idling at 90 degrees outside temperature with the A/C on full cold. The

freon temperature (using the R-12 scale) should be ~38 degrees. Make sure the condenser cooling fan comes on. I will tell you right now that the hardest part of the whole job is finding someone who will charge the system for you. There are a lot of misconceptions about A/C out there. The R 414B does not need to have the oil changed to use it. Here's the links:

For Hot-Shot info go to: <http://www.icorinternational.com/>

Gary doesn't have a web site but I did a page on the hoses he made for me at:

<http://www.angelfire.com/pa3/lyzcoinc/AC.html>

And this page shows the hose installed in my car:

<http://www.angelfire.com/pa3/lyzcoinc/tcic.html>

- 
- R-12 Freon Alternatives by Merkurman  
Autofrost nor any "blend" is not the "way-to-go" and a no-brainer would be to use R-12... There are some issues that the Autofrost promoter didn't provide...One, Autofrost is a blend which has composition issues which means that if the system leaks a little you cannot just top of the system and insure the Freon levels and concentrations will be the same.... Two, the R-22 in Autofrost and other blends, despite what the Autofrost tech support claims, eats up neoprene o-rings...Autofrost is 55% R-22 and R-22 operates at a lot higher system pressures and that is why it's used in stationery refrigeration primarily.. Third, since your system was designed for R-12 why not use it or a stable refrigerant like R-134a?

I look at things like this: The system needs to be clean and sealed to work with any refrigerant. The service on your a/c system is miniscule compared to the work on the engine, brakes, tranny, etc.....So why not do it once and do it right?

The oil in the system, if it hasn't been changed, is a minimum of 13 yrs old. Why not change it? Flush out the system to remove any debris and while you are at it change the receiver since it is also min. 13 yrs old and the rubber hoses are also min. 13 yrs. old...A blown desiccant bag is a bad thing plus if the desiccant is saturated, it won't remove moisture from the refrigerant... No reason to get the system up to current standards.... You can use a synthetic refrigerant oil that will work with any refrigerant...Texaco HFC-100 or Polyalpha+ works with R-12 and R-134a as well as the blends too...Blends usually have some added component to help it pull oil through the system to help lubricate the compressor.. There is a R-134a expansion valve for the Merkur that you can change over if you go that way...I would change it though since it is also min. 13 yrs. old and it determines the metering of the refrigerant into and out of the evaporator...Insure the condenser fan works when the a/c is on, the system is vacuumed down, squeaky clean and leak free, and the vent temps either with R-12 and R-134a will be in the 40's with high fan and mid-upper 30's on low and mid fan....

PS...Never use flush solvent in a compressor; only use the refrigerant oil used in the system to flow through the compressor to remove all old oil....

If you want to get the real lowdown on blends, go to [www.aircondition.com](http://www.aircondition.com) and ask the folks that do this for a living daily not a hyped web site on the blend....

- 
- Three groove crankshaft pulley question by Preston Anderson  
Q: I just pulled a 3-groove crank pulley off an 83 Turbo-coupe. It appears to be a correct substitute, but before I pull things apart on my XR to install it, can anyone confirm that it's the right part?  
A: I'd suggest also grabbing the 2 groove water pump pulley. You will want to use them as a pair. You can leave the 3 groove water pump pulley on but it will be hard to put on the AC belt and it will likely rub (but it still works). I just did this conversion on Monday. AAH, the silence is wonderful. I also found the desired pulley(s) on an 83 TurboCoupe.

- 
- A/C Clutch Replacement by Ken Kiser

**Q:** I have a spare compressor which I know is sound, but the clutch is shot. I have another compressor which is shot, but the clutch is decent. Does any one have the procedure for removing the clutch off of the Nippon A/C compressor handy?

**A:** Nothing particularly exotic: 12mm nut on the outer plate; a snap ring on the pulley/bearing; and a snap ring on the electromagnet. Your snap ring pliers need to be pretty stout.

The outer plate may require the special puller tool (~\$35 from NAPA), but it isn't really that tight on the shaft (on the compressors I've handled).

Pay attention to the washers under the outer plate; they're important to get the correct spacing between it and the pulley. Also, make sure you get the snap rings back with the bevel facing out.

---

- A/C Converting to R134A by Ruben James

**Q:** My 89XR needs an A/C recharge. Does anyone have advice on converting to 134a refrigerant?

**A:** Are you doing the a/c work yourself? If so, get the hoses rebuilt with barrier hose; Great for R134a and R12....R12 can be bought from Ebay and other sources though....

Changing the mineral oil in the system is key to using a different refrigerant...There are oils that can be used with all refrigerants that will not absorb moisture like mineral or ester oil...Changing the expansion valve isn't necessary but it's something that I would recommend while the system is apart...Plus the receiver-dryer does need to be changed out too...

Expansion valves are 33-35 dollars from Autozone and the receiver-dryer is about 70-80 from Hancock Industries....If you need the trinary switch it's 30 or so from Vintage Air in San Antonio...

I would also reseal the compressor with an O-ring kit if the compressor is still turning....Flushing the old oil from the unit with the newer oil is the way to go and there is not that much oil in the compressor anyway...

If you need diagrams of the compressor breakdown or a source for the o-ring kit, let me know....Some folks have had problems with the kit and I would reseal it while it's off the car and the system is open...

When you refill with R-134a, you only need to use about 60-80% of the weight capacity of R-12...The sight glass in the R-D is not a useful tool anymore either...But R-134a can be used in the Merkurs with the same condenser and cool into the mid 30's...Typical is 37-45 F vent temps...Really close to R-12 temps....

---

- Additional source for the Scorpio Condenser cooling fan by Roger Jones  
I had sticker shock once when my Condenser Cooling Fan failed on my '88 Scorpio. I can't recall if it was the RARE because it was a version used only on early or late production. However, it was more than \$800 USD. I was lucky at that time to find an ambitious motor shop to revive it.

While stumbling through the Kruse Auction Preview at the AACA Eastern Region Annual Meet, I spied that elusive Fan Motor again. THIS TIME it was fitted not to a Scorpio, but a 1989 Mercedes 560 SEC. Check your bone yards for the late '80's/ early '90's Mercedes S-Class. Grab a Fan, be a hero.

---

- Scorpio Air Distribution Control Motors by Roger Jones

**Q:** I learned today that Hartwood Automotive, Fredricksburg, VA is no longer able to supply ATC "Vent Motors" as they are defined in the Scorpio Shop Manual. Neither are they able to supply the Vehicle Speed Sensor which I purchase last June.

I want to thank Roger Jones for his very informative email that helped me understand what I was seeing and reading in the Shop Manual regarding what Roger defines as the "Air Distribution Actuator".



I have discovered since seeing the Service Code "16" in the ATC control module temperature display that by setting the "Def", "Pnl" and "Flr" to the on position, illuminated that is, I'm able to get heat to the center panel outlets, the defroster and I think to the floor outlet. However, on "Automatic", I only get heat to the defroster.

We have a local auto serviceman who had experience with Scorpions when they were popular.. He also believes that we need a new "Vent Motor" and suggested if we were going to replace one that we replace both the LH & RH and Center "Vent Motor".

There doesn't seem to be any urgency to do this now that I've discovered that I can get heat.

I'm assuming that I'll be able to get some A/C cooling even though it may not be automatically controlled.

I'd appreciate any recommendations that you may have regarding replacement of the "Vent Motors". I won't be doing the work myself so I know that it will be expensive to remove the panel, etc.

**A:** Hey, thanks for the compliment.

First you need to be sure you have a very strong diagnostician for a mechanic.

I never replace ANYTHING until I've thoroughly checked both it and it's driving circuit. You need someone who can confirm that each Actuator Assembly is getting the correct Polarity Drive Voltage at the proper and specified times and the inverse at the correct and specified times. This would determine what is causing the problem - defective Actuator Assy.(s) or a failed EATC control head, wiring, etc.

At the same time it would be wise to monitor the Resistance of the Position Potentiometers as the Actuator Assy.s are driven.

The Scorpio has five (5) Actuator Assy.s.

There is one that drives the two Center Dash Vents together. This one is unique from the others as it does NOT have a Potentiometer. This Actuator Assy. is driven with DC Voltage for a specified period of time to either the Fully Closed or Fully Open positions and it's end-of-travel is limited by physically binding at it's stop.

All other Actuator Assy.s DO contain Potentiometers as they are intended to be controlled to stop at variable positions within their limits of travel and they are fully interchangeable with one another. This aids in troubleshooting as you can move them around to determine if a suspect Actuator Assy. fails to operate in more than one circuit.

Having one Actuator Assy. that's actually broken is not uncommon. It implies nothing more, however, and I do NOT recommend replacing any additional Actuator Assy.s than the one(s) that are broken.

Further, with a solid understanding of their build and operation and with access to parts and tools, I believe it's possible to repair any defect within an Actuator Assy. Practically eliminating the need for buying/ acquiring a replacement.

In the worst case you can get some parts, add in an Actuator Assy. to cannibalize and get 7 to 9 good ones from a batch of 10.

If you're able to operate a screwdriver and willing to buy a few odd-ball sized and shaped Phillips heads screwdrivers, you should be able to get most of this done yourself. Then find some old guy in a radio/ stereo repair shop off the beaten path to do the Actuator rebuilds and YOU're good to go.

Your biggest risk is getting a cracked Upper Dash Pad by tightening it's retaining screws. FYI, there was a Ford TSB about leaving the Screws around the Instrument Binnacle less than tight. I would suggest modest/ slight tightening on all of the Dash Pad Retaining Screws.

I would suspect your current mechanic has already over tightened the Screws.

Carlisle is right around the corner and I'll be available for repairs and consultations live-time.



## Automatic Transmission

---

- Is the C3 Trans strong enough ? by Dave Compton

The C3 is not weak. Most people just hop up cars with over 100k miles on them and don't perform adequate maintenance. Then they declare the tranny was weak when it breaks. Sure it was weak, it had 100k mile old fluid in it. They rarely rebuild it properly, and maintain it thereafter. If they had, they would still be driving on it. It's very popular to swap in a manual transmission. Doesn't make sense to me, but that's what usually happens.

The C3 should take 250 hp or more in top shape. That's an off the top of my head guess, but I know that A4LDs can be built to take 400 lbs of torque and it's the same transmission with an overdrive stuck on the back of it.

Here's a few things that will make it last longer:

If the radiator is not new or recent, bypass the in-radiator cooler for the auto trans. If it leaks and you get coolant in your tranny fluid the tranny will need to be rebuilt. When you bypass the internal cooler, install a LARGE external auto tranny fluid cooler. I'd remove the stock external cooler in the interests of simplicity.

Never power brake an automatic transmission. Figure you're taking 5000 miles off of the life of the transmission every time you do it. And that's with a new tranny with a lifespan expectancy of 100k miles. So about 20 times power braking it and it will soon start to slip. If it's used, and has some mileage already on it, you're playing Russian roulette.

Change the fluid and filter, clean out the pan. Every 20 K miles. Just use the specified fluid, no need for additives.

Make sure that the cable is properly adjusted so that the tranny shifts quickly and cleanly under WOT at about 5200 RPM. If the shift is slow, it's burning up the bands.

Make sure the vacuum modulator is in good shape, and not leaking fluid. Pull off the vacuum hose to it, to check it. Check out the condition of that line also.

Make sure the cooler lines are in good shape, and not leaking fluid.

Check the fluid regularly for a drop in level or a burnt smell. The fluid should be a clear red color, not brown, milky, or opaque.

Fluid is the blood of the transmission, if the blood is bad, it's dead.

Transgo makes a god shift kit for the C3 that works well, just make sure to NOT follow the directions regarding the check ball installation in the reverse circuit or you will not have a reverse gear. For the cost, this is a good mod.

I recommend you become familiar with your transmission by doing the mods and performing the maintenance yourself. This will get you familiar with it, and hopefully prevent a visit to a professional.

If worse comes to worst, the soft part rebuild kit from NAPA is about \$75, and you can do it at home, with a \$20 book. The hard parts very rarely break.

The only negative to the C3 is that it doesn't have an overdrive and a modified XR will reach 100 in a hurry. 110-120, somewhere in there is Redline, and it's just no fun screaming down the highway at 5000 rpm when cruising fast. For a fun car to drive around and back and forth to work, a modified XR automatic is a total blast. Exhaust, boost bleed, maybe later an intercooler and

cam, and it'll surprise the hell out of ya. You might get beat for the first 50 feet, but after that, you are gone. :) It's no trouble to wax a vette or other much more powerful car out on the freeway.

All these tips and statements apply to a street driven car with street tires, not a dedicated drag racer with slicks. If you are racing alot you will break it sooner. But you will be surprised how long it lasts...

---

- Flushing the Automatic Transmission Fluid by Lih-Yin Hsieh

A common DIY technique for getting \_all\_ fluid out is to intercept and divert the return fluid (cooled) at the radiator. Relatively easy.

Gather a couple of used gallon milk jars, and use magic marker to add tick marks to the jars in quart gradations. Get enough fresh ATF. I would say two times the capacity. Get/make a collector hose (see below.)

Run the car until the tranny fluid reaches operating temperature.

First, drain old (HOT, TOO!) ATF from the drain pan into a collecting container – a graduated gallon milk jar so you know how much to fill up.) You may want to service the pan (replace filter, gasket, etc.) before proceeding. Fill the system back up with fresh ATF in the same amount as you drained out.

Disconnect the cooler return line at the radiator, attach a hose with proper fitting and route it to a collection jar. You may be able to substitute the jig hose with clear Tygon tubing if there is enough threads on the radiator fitting to hold the clear tubing onto (these are available at Home Depot or equivalent.) Run the engine to collect old ATF. At the same time replenish with fresh ATF at equal rate from the filler tube. An assistant can help exercise the transmission to achieve better result, but make sure you ...

**TAKE ALL PROPER PRECAUTIONS:** block the wheels, apply parking and service brakes, and never stand in front or behind the car!

Put the transmission through gears, staying in each for a minute.

When the ATF coming out from the radiator return becomes clear you are done with replacing the fluid. Reconnect the cooler return line.

---

- Draining the Torque Converter by Bill Melvin & Lih-Yin Hsieh

**A1:** Shifting through the gears as that should remove a small amount of fluid from the servos. I would add that the line from the transmission to the radiator is the one on the top (Scorpio). This is the one I use. I usually cut the plastic tab above the line so I can get a backup wrench on the fitting to prevent any damage when loosening the line.

**A2:** Yeah, the idea is to get as much of the old ATF out as possible. The cooler, to be effective, probably holds non-trivial amount of fluid. That's why you catch the fluid at the cooler return fitting. If it is not clear which line is which, just open either and run the engine. If fluid comes out from the cooler, the line you opened is the return (and use it.) If fluid comes out from the line, it is the feed. The flow is rather moderate. You shut off the engine and the fluid stops.

Bill is absolutely right. Use a backup wrench unless you want to mangle the radiator.

---

- Transmission vacuum modulator by Don and Others

**Q1:** With the motor off, should I even be able to pull a vacuum with the tranny line connected to the tree?

**Q2:** Would a low tranny fluid level cause the motor to not be able to generate a vacuum, and thus run rich? (it occurred to me after cleaning up tonight that I did loose some fluid when re-plumbing the front lines, and it may have been low already regardless).

**A1:** The line down to the tranny modulator should hold a vacuum, replace the modulator if it doesn't. It will tend to not upshift until you let off the gas when the modulator is bad. The turbo modulator is not easy to get. Most parts guys will get you a stock C-3 modulator, I'm pretty sure it's not the same. I guess you could put in a check valve so that boost doesn't enter the modulator. This brings up another oddity. I have tested some vacuum trees. Some have a built in check valve, other's don't. Anybody have anymore info on this? If the modulator is bad, it will suck tranny fluid into the manifold, if it doesn't have a built in check valve. This could make the flame thrower effect but I'm not positive if trans fluid would do this. Maybe auto cars had a different vacuum tree? That sounds HIGHLY unlikely to me.

A: Vacuum to the modulator is supplied through a steel tube from the vacuum tree, and then a small S-like section of vacuum hose connects to the modulator. That section of hose could be the leaker. I've replaced that section without removing/loosening anything, but the working space is tight and it took patience and some creativity. Replacing the modulator involves ideally loosening the trans mount crossmember and the down pipe--nothing major there, just time consuming--and the space to work in is still cramped as the modulator fits into the upper part of the trans housing.

I got a new turbo engine modulator a few months ago from JCWhitney ("CarParts") @ ~\$27.00 including shipping. Exact same part as OEM.

Available here:

<http://wrenchhead.carparts.com/cgi-bin/sewse?/u/www/webepc.com/cmm/scripts/epc20.cmm+jcw-carparts>

Even less than I first remembered---\$13.62 for the part.

YMMV

- Scorpio Speed Sensor by Jake Delgado

**Q1:** Would somebody please tell me where EXACTLY the speed sensor is located on the Scorpio A4LD trans. I'm going to try to swap speed sensors from my parts car to the daily driver this weekend.

**A1:** The speed sensor is located on the left side of the transmission about the middle of the tail shaft housing. It will be the only thing there with wires going to it. You will probably have to drop the heat shield and slide it back to access the sensor. There should be a ground strap from the retaining bolt for the sensor to one of the 4 bolts for the transmission cross member.

## Bodywork-Electrical

---

- Rear Hatch Open Indicator Switch Replacement by Lih-Yen

To remove the trim panel buttons, I used an awl to pry in and lift one side of the button, then I used a small flat screw driver to completely lift the button up. It took about two minutes to remove all 10.

There is a lock barrel retaining clip, inside the hatch sheet metal, rectangular in shape, about 1.5" x 2", that spring-locks the lock barrel to the hatch outer sheet metal. This usually is the one hidden piece that frustrates people the most. Once you know it is there you don't even need a dental mirror.

It is easier to remove the hatch lock solenoid first if servicing the hatch lock is desired, so after you remove the trim panel, disconnect both the hatch micro switch and solenoid connectors from the harness, then unscrew the solenoid from the housing piece, and gently separate the actuating rod from the solenoid clip. At this point reach in the cavity between the two hatch panels, feel around, and pull out the lock barrel retaining clip. Use a piece of rag/shop towel to protect the back of you hand. The barrel will simply slide out. I had only one very minor bruise in doing this. Then you can examine how the components are (mal)functioning, clean, and regrease, etc., with much ease.

The hardest part is reattaching the lock actuating rod to the solenoid clip. Practice assembling with both the lock and solenoid out of the car, and take a mental picture of how the rod should be positioned and attached to the clip may prove to help very much. After putting the barrel back in place and locked with the retained clip, I first attached the rod to the solenoid clip, then screwed the solenoid back to the housing piece.

Having small hands definitely helps a lot, as in my case. The shop manual, which tells you about this lock barrel clip, is the biggest help.

- 
- Scorpio Euro Headlight Wiring question by Chris Senior

**Q:** I found a good set of European Scorpio Headlamps at an English junkyard and brought them back. I wired them with 4 relays for the 2 headlight bulbs but I'm having some problems:  
- Headlight out indicator illuminates on both sides whenever low beams are on (including flash-to-pass)

- Blue "brights on" idiot light illuminates if stock foglamps are on, regardless of if brights are on

- If stock fog lamps are on and you flash-to-pass, both high & low headlights remain on after releasing the stalk (and stay on indefinitely)

Any suggestions?

**A:** I bought a Scorpio back in January with Euro lights. They were wired the same way. I rewired the entire setup using only one relay. The main headlights I wired directly to the Scorpio headlights eliminating the relay. I then ran a new circuit for the center lights. Signaling a relay when the high beams are on. I then wired the small lights to the Scorpio center marker light so they come on with the parking lights. They look great with the parking lights having the headlights lit up dimly. It sounds light this setup is very similar to they way they are supposed to be wired. The indicator works now also. I used 14 gauge wire for the center high beams just in case I want to use a slightly larger bulb in the future. I don't know why I would want to seeing how with the high beams on it turns night into day already.

- 
- Fuel cut off Inertia switch by Lih-Yen

Inertia switch at the rear, under the carpet flap covering the back of the taillights where the jack is stowed. Black box, little white button. There is an inertia switch along the edge of the rear hatch where the latch the striker in the deck lid catches on to. To reset it, push it in. It is a white tab.

---

- Taillights going Crazy by Pat Hoogendyke

**Q:** I have a problem with my 85xr. When I apply the brakes, the rear right taillight goes nuts. The turn signal and reverse light turns on with the brakes. I checked all the bulbs and wiring and everything seems OK. Any suggestions.

**A:** Its a ground problem...take a piece of wire and screw it into the metal where all the bulbs sit in and then to the body in the trunk somewhere.. if still nothing then clean the connection .They sometimes corrode there.

---

- Scorpio License plate bulbs by Pual Kuettel

The way to replace these is to go to an appliance store and get perfect replacement 5 watt capsules. Get the perfect fit 10 watters at the Auto Part Mall, and they will melt your irreplaceable lenses.

Take your burned out bulb (sounds like a description of my brain) to your local appliance parts store and say it came out of your Fridgeaire. They will come back with a perfect fit 5W replacement, no adaptation needed. \$1.20 tops.

---

- Plasma HID headlights ????? by Lih-Yen

**Q:** What's the deal, anyone used 'em ?

**A:** On the "HID" lighting & blue bulbs, you might want to check out Daniel Stern Lighting at <http://lighting.mbz.org/about/> super-white, high-power bulbs, in most stock US-specification cars, just means a brighter bad pattern for the driver & even more glare for oncoming traffic. the free tech info is tops for serious drivers. We know who we are!

Daniel seems to have a degree in physics, or enough practical knowledge to offer Automotive Lighting 501. He had a great debate with a commercial pilot a while ago debunking a lot of misconceptions and mysteries about car headlights. I enjoyed reading his stuff on high wattage bulbs, HID, fake HID, blue, super white, yellow lights, what have you. For those of us concerned enough about our own, and other drivers' night time road safety as it relates to headlights, I second J. R.'s recommendation without reservation.

---

- Scorpio Instrument Cluster by Jim Wirt

**Q:** My speedometer was working just lovely up until about a week ago. Now it goes up to about 40 and just kind of hovers. Or it doesn't go up past 5. Sometimes it goes to the right place, but only momentary. One message I read said it was a gear in the odometer. Is this correct?

**A:** The speedometers in our Scorpions are electronic units made by VDO. The speedometer gets its signal from the Vehicle Speed Sensor (VSS) on the transmission. This is a Hall Effect device that sends a square wave signal to the speedometer assembly. The frequency of this signal is twice the indicated speed. For example, if the VSS sends a signal with a frequency of 120 Hz, then the speed will show 60 MPH.

If the speedo is acting up, it is NOT a gear issue. The gear is part of the odometer/tripmeter drive. If the odometer/tripmeter has stopped advancing, but the speedometer is still working, then that is the indication of a stripped gear.

If you are seeing intermittent behavior of the speedo, it is more likely that the problem lies with the VSS and not with the speedometer assembly. Here is another test:

Your cruise control also uses the signal from the VSS to know how fast the car is traveling and is completely independent of the speedo. If you set the cruise and it cannot hold the set speed, it is almost certainly a problem with the VSS. If the cruise works OK, but the speedo is still acting up, then it the speedometer itself is probably at fault.

I had the VSS fail intermittently as you describe on one of my 88 Scorpions a few months ago. I was able to get the Ford part from Fusz Ford for about \$80. This is an easy part to replace as it is held in place with one bolt near the driver's side rear of the transmission. Reuse the gear and clip on the old VSS.

- 
- More Scorio Speedometer Troubleshooting by Jim Wirt

**Q:** I noticed that my odometer and my trip odometer just suddenly quit working all together. I'm thinking that it must be something underneath the hood

**A:** If the speedometer works and the fuel computer is showing reasonable numbers, then it means that your vehicle speed sensor (VSS) is fine and it is unlikely that it is an electrical problem.

The usual suspect in an odometer and trip meter failure with the speedo still working, is a stripped gear in the odometer assembly. There is a small, fragile, 20-tooth driven gear that VDO made out of a plastic that is guaranteed to deteriorate with age inside the environment of an automobile. The stepper motor will still operate but the odometer will not advance.

Here is a link to test, diagnosis, and repair instructions:

<http://www.bitsprings.com/gearinst.pdf>

- 
- Polishing Headlights by Greg Munizich

There was some posts about polishing plastic headlights recently. I just want to let someone know how I did mine last night. I have access to some tools that make this method good for me but maybe not for someone else. The critical issues being a cotton wheel on a long mandrel and rouge. If you are going to do it by hand you might as well leave the lights on the car. Protect the car from scratches somehow and start sanding. Regardless of how you do it, remember that the plastic is getting very brittle at this point, and can crack on you.

Step 1 = carefully remove grill and check it for cracks. while it is off it is a good time to wash the back of the grill and epoxy any cracks from behind. I used some "Goop" brand "marine", 2 part, 5-minute epoxy (works great).

Step 2 = use a long skinny screwdriver to carefully pry the steel clips that hold the plastic posts on the adjusting screw heads. They only need to move a little to let the light slip off. I removed the "ring nut" that holds the bulb in place and the bulbs. Don't touch the glass part of the bulbs with your fingers. The oil from your skin will ruin the bulb quickly.

Step 3 = I used 400 grit "wet" paper and wet sanded all the cloudy film off. Then I used 600 grit wet paper to finish sand the surface. I skipped the 1000 grit wet paper because I don't have a show car. Don't use anything more coarse because if you put alot of sanding scratches in the face then it is just more work to sand them out too. The 3 bumps on the face sure make it kind of a pain to sand. Work over a bench to make the sanding safer. If you drop the light it hopefully wont hit the floor and break.

If you are not used to working around machinery and spinning tools you should do this by hand with polishing compound and a cloth! It is easy to twist your shirt up with the mandrel and tear out a chunk of skin and make this a bad day.

Step 4 = I used a cotton wheel with white rouge to polish the faces. I have done plastic polishing at work before and have some experience. I bought the wheel and compound at Sears. I polished the faces to my liking ( not perfect ).

Step 5 = I used "409" and Luke warm water and washed the lights inside and out. Inspected the lights and epoxied the cracks to keep the water out. Let the inside of the lights dry out or they will be foggy inside. Pry the clips back slightly and install the lights. My car is a daily driver so I installed the lights on the car before they were dry. I waited for a sunny day and pulled out the bulbs and let them dry out.



Step 6 = You need to wax the lights a couple of times to protect them. I didn't sand the smaller lights. I only used some polishing compound by hand to shine them up.

Step 7 = Install the grill.

I am not an expert on this and I don't know if they will cloud up or yellow sooner due to sanding off the top layer of plastic. It took me about 4 hours to do this. My lights look great.

---

Refurbishing and repainting headlights by T. LaMers

**Q:** I am the proud owner of an 88 XR4ti and I continue to be astounded by how modern the design of this car is.. however, I do find my headlights are the only sign of the actual age of my Merk. Does anyone have any tips or suggestions on how to clean the lenses, or is that impossible? I was considering the complete replacement option with the Euro lights available-but thought there may be a solution in the shipping interim..

**A:** What I have done is to sand off all the factory clearcoat (this is the layer which yellows and protects the Lexan underneath) and then re-clearcoat the lenses. I used PPG two component acrylic urethane clearcoat and am perfectly pleased with the appearance and leakproof results. Did the same on my '88 Scorpio in 1994 and it still looks "new".

For sanding I used 400 grit wet-or-dry paper wet. Purchase the clearcoat at an auto paint supply and spray it or take the car with sanded headlights to any body shop and ask them to clearcoat the lenses. No need to remove from car.

---

87 XR Rear Defroster Troubleshooting by T. Rhinesmith

I had a problem with my rear defroster not working in the blue 89 several years ago. As we all know, this rear grid "not only functions as an antennae but also as a defroster! " <In the spirit of Ronco Ginsu knives/ pocket fisherman advertising. :-)

I didn't have a problem with blowing the 30 amp fuse in the fuse block, but the defroster just wouldn't work. It turned out that it was the case of another solder joint going south. I took the black cowling panel off to gain access to the unit, and gently disassembled it. I think it was a reddish/orange plastic box held together with some kind of clips, which had to be destroyed in disassembling the darned thing. I then found that the problem was that the heat going to the defroster grid was enough heat to melt the solder joint, thus no longer completing the circuit.

A heater element is just a controlled short circuit. If they draw too many amps, they will go through meltdown or blow fuses. If the soldering or wiring is deteriorating at your joint connection, the amp draw will be too much for the circuit, and blow the fuse. I just took the British unit out and resoldered the joint. It has worked perfectly ever since.

That gizmo being from the Brits reminds me of that old joke about Lucas electric:

Why do the English drink their beer warm? Because their refrigerators are made by Lucas!

---

• Fixing Slow Windshield Wipers on the XR. by Richard Curtis

The solution was as Chris Anglin suggested: Disassembling the wiper linkage, cleaning the wiper posts, lubricating and reassembling. Now they work easily (and at TWO speeds instead of one). Several Merkhheads suggested a variety of fixes but Chris had it pegged.

here's how I fixed it, in case someone else has the same problem:

--Remove wipers.

--Remove the black plastic covering between the false firewall and the windshield that hides the wiper motor, heater fan box, etc. (3 little screws)

--Remove the windshield cowling grill (black plastic. You may or may not be able to salvage the plastic screws that secure it. You can buy new ones from OPMD or other Merkur vendors). In addition to the large center piece, you'll also have to remove the driver's side corner piece of cowling. You won't need to remove the passenger side cowling.



-- Remove 6 torx head bolts (T-35) that secure the wiper linkage to the body.  
--Remove 2 T-35 torx head bolts that secure the wiper motor bracket to the body.  
--Remove the whole shebang, being careful to unhook the electrical connection to the wiper motor.  
--Lay on workbench.  
--Remove the C-clip that secures one wiper post to the linkage. You can do this with a small screwdriver, tapping it with a hammer LIGHTLY. Watch it...that little C-clip just may fly across the room into the darkest resources of your garage, or if you're working outside, springing into the azaleas.  
--Remove 2 or 3 very thin spacers/washers (one post had 2 the other had 3).  
--Slide the wiper post out of the bushing.  
--Clean the bushing thoroughly. I then lubricated it with light grease.  
--Clean the wiper post. I used 400 grit sandpaper. Lubricate it also.  
--Reassembly is the opposite of disassembly.  
Hope this helps.

---

- Cleaning power window switches on 86 XR. by Bud of Virginia Beach  
On my 86 I have fixed the switches many times. The problem is the high current across the contacts makes them dirty and will not make contact.(very bad if window is down in rain/snow)  
Remove three phillips screws holding cover around the shifter, lift up gently, reach under and remove switch wire contacts. take cover out to bench.  
The switchbox will push out of the cover. With a small flat-blade pry the cover off. Gently lift buttons off. You will see the metal rocker contacts. Take them out, clean all contacts with alcohol/contact cleaner. Now you may need to rub off the black carbon buildup. Use stiff brush or 600 grit sandpaper. Clean again.  
If you want or need to you can drop a bead of solder to build up the contact surface. Don't get too much solder on it. Put the rockers back in place, press the pushbuttons into the slots on both sides, reassemble box, insert box into shift cover. Connect wires (tricky cause you can't see the mating points easily) Now windows should work great for awhile longer. If you get tired of messing with this, BAT Inc has a new set.  
**From Dale:** Excellent step by step write up. One quick comment. My switches pry right out of the shifter surround; no need to remove it. There's enough length in the wiring to easily unplug and re-plug the switches.

---

Rear Window Wiper Repair By Richard Curtis

I've just replaced two rear wiper motors in my two 89XRs (yes, one XR is STILL for sale). For the first one, I replaced the rear wiper motor with one bought on eBay. For the second one, I disassembled the one I took from the first one and repaired it. Here's how I repaired the one:

After you've removed the rear wiper motor (if it's not obvious, e-mail me offline and I'll explain it, but it's very easy. Tip: First remove the rear wiper itself), remove the black sleeve that fits over the shaft onto which the wiper itself is fastened.

Then remove the washer and O-ring. Then remove the C-clip around the shaft. Be careful with the C-clip, it will go springgg off into the darkest corner of your garage. Ask me how I know.

Next, turn over the wiper motor assembly. You'll notice 7 or 8 very small knurled studs that secure a cover plate to the assembly (why they didn't use simple screws, I'll never know). You'll need to grind these off. I used a cutoff wheel on my Dremel and ground them smooth. Took 5 minutes.

Remove the cover plate. It will probably take some prying. There will be a paper gasket. Discard it. Inside the assembly, you'll notice a lot of dried up grease. This is why the wiper motor doesn't work, or only works sporadically (mine was working in that it would move the wiper blade to the "noon" position but then stop). Remove the shaft assembly; it simply slides out. Remove the plastic, geared drive wheel (might take a little nudge with a screwdriver but it's just a slip fit).

Clean out all the old grease. I used a screwdriver to scrape away most of the grease, washed the shaft assembly and the geared drive wheel in my parts cleaner then sprayed the inside of the motor assembly with brake cleaner and wiped everything clean.  
Now re-lubricate with your favorite grease.

Reassemble everything in reverse order, using RTV sealant to reattach and seal the cover plate. For extra security, use a large nylon cable tie around the wiper motor assembly to make sure the cover plate doesn't come off although all it's holding in is the grease.

---

Power Window fix By Lih-Yen

Have done this many times using brake cleaner to clean out the grease, then with contact cleaner to clean the points, and after lightly scraping/polishing the contact surfaces, contact cleaner, and by brake cleaner, in that exact sequence.

I use axle bearing grease to **lightly** lube the mechanical parts: plastic plungers tips and bodies (watch those tiny springs inside the switch cap plunger shafts!), and just a little bit in the channels of the contact rockers.

Notice that I **did not** say to 'lube the contacts'. They should be kept as clean as possible.

- How do you polish the contacts: (If you have the time and patience, that is.) These will be curved concave and convex due to pitting and metal transfer. Use very fine wet/dry sandpaper, 600 or 1000 grit, to smooth out the points on the rocker blade. Cut thin strips (about 1/4 inch wide), sandwich it between the rocker blade and the fixed point, and with the abrasive facing the points on the fixed point. Pull the sandpaper through this sandwich while applying light pressure on the points. Repeat until the contact surface is at least somewhat shiny.

- Why I had to do it many times:

Cumulative my Merkurs have clocked 495 K miles. IMHO, once you have a need to clean the contacts, it will resurface every few months or a couple of thousand of uses. Either you will have to buy new switch assemblies, or modify the switch with arc absorbing RC circuits. SIGH! I have gathered some information on the circuit but never found the time to implement.

---

Cleaning power window switches on 86 XR. by Mark Meyer

**Q:** Hi All, I'm working on restoring my '88 xr4, and the passenger side window doesn't work. Are there individual fuses for each side window? I have the door panel off how do you remove the motor assembly? it looks like its riveted. I've already changed out the switch with a brand new one. Whatcha think guys?

**A:** There are two Torx screws that hold the motor on the regulator. Typically there's a pile of goop in the bottom of the motor case. Clean it out, grease it up, see if it works.

---

Replace Scorpio Front Turn Signal Bulb By Jake Delgado

**Q:** After 4 years of owning this car, finally a bulb burned out. I don't want to break anything in the process of replacing it. I am sure that you guys have done this more than once. Please let me know how.

**A:** The bulb is really easy to change and no tools are required. With the hood up, look at the front corner of the engine compartment on the side where the bulb is burned out just behind and below the radiator support. There is a spring about 2-3 inches below the top of the fender with a loop in the end about 1 inch in diameter. Pull that loop toward the rear of the car just enough to unhook it from the sheet metal and move the loop toward the outside of the car while maintaining the pull. Once you have released that spring, the signal light can be gently pulled out of the opening by pulling away from the centerline of the car and slightly forward. There are two plastic locating dowels on the signal light that have to go back in their holes when you put the assembly back in the car. Replacing the bulb is simply a matter of rotating the holder counter-clockwise about 1/4 turn and it will come right out. Press in and turn at the same time to remove the bulb from the holder. Assemble in the reverse order and make sure you have the plastic dowels properly aligned before you try to re-hook the spring or it won't work.

---

- Finding a persistent battery drain by Richard Curtis

A common cause of a battery drain in XRs, is that the passenger- side door lock solenoid gets gummy and only half-actuates, causing a drain. I've found this to be the case in two XRs, I've

owned. The test for it is to lock both doors using the driver's side lock, and watching the passenger door lock to see if it locks all the way; ditto on unlocking. You can easily remove the passenger door panel and spray some lithium grease or Tri- Flow or similar lubricant on the solenoid rod.

If you want to track down battery drains, hook up your digital volt meter in series with the battery (between the negative post and the negative cable). You should see something less than 100 millivolts (on one of my cars the steady drain is about 50 millivolts). You'll always have some steady drain on this order because the radio and the clock, for example, are always "on" plus I think there's a small continuous voltage to the EEC. If you see voltage greater than 100 mV, start pulling fuses one at a time until the voltage on the DVM drop. Then you've at least found the circuit causing the problem.

Another problem I've observed on another of my non-Merkur cars is defective door light switches. If they're defective, they'll drain the battery also. Ditto for power window switches. On one of my non-Merkur cars, the passenger window switch can be accidentally be pushed UP all the way (where it will stick), causing the battery to drain in very short order. All of these are worth checking on an XR.

## Bodywork

---

- Fender repair/reinstall by Dirk Nansen

A good body man can do a lot to straighten and repair a fender. But it is getting hard to find those guys as most shops just replace parts these days. It is not too hard to replace the fender. Removal is easier than it looks and can be done in 15 minutes or so with a little practice. Fitting the new fender can be more tricky and may require a professional. Probably the best bet is to remove it yourself and have a body shop (willing to work with you) install the new fender so they get it lined up just right. When removing the damaged fender, don't drill out the spot welds. You need the special spot weld cutter available from some auto parts stores (\$15-\$85) but more likely from an auto body supply shop (the kind that supplies materials to body shops). It a small hole cutting drill bit set up so it cuts out only the top layer of the spot weld leaving the underneath surface intact. This is important so you can weld the new fender in place (can't weld to holes very well).

The front end is a little tricky as the welds are harder to get to. If you can't reach them with the spot cutter, use a die grinder and try to just grind to weld away. Use a wood chisel or similar to gently pry the two surfaces apart after the welds are cut. Often there will be remnants of the weld that aren't quite cut through and the chisel will break those loose. Also, there may be some bonding compound in the joint so it needs a little prying. There are a couple spots on the top seam that are crimped over and you need to bend back the tab.

Remove the bumper skin so you can get at the few spots on the underside of the front of the fender. The back of the fender on the door post has a conventional line weld that has to be ground off. Then you need a knife to cut through the undercoat glop on the inside of the fender that glues it to the door post. There are also a few spots or conventional welds on the rear bottom seam of the fender. Be patient and get them all so you don't distort the metal more than necessary.

BAT sells new fenders for \$150 which is a good deal considering what it costs to repair even slight damage to a salvage fender. But you will need to have them painted. If you are lucky to find a salvage fender in the right color with no damage, you could save some money by using it. Most salvage yards will just saw off the whole corner of the car (called a "clip") and leave it to you to separate the fender. The replacement salvaged fender can be harvested by just drilling out the spot welds as that will leave nice little holes convenient for welding to the car structure (assuming you didn't drill holes in the car structure removing the damaged fender). The robot welders tend to make all the welds in the same place so the holes in the salvage fender will probably line up with the spots in the car structure.

Be sure to grind or file the remnants of the spot welds flush and straighten out the mating surface to which the fender attaches before fitting the new fender. This is where it gets interesting. Often there is some "adjustment" needed to get the fender to line up just right with the hood and the door. The XR nose structure is pretty soft and any significant impact is likely to have shifted it some so don't be surprised if it doesn't want to line up just right by itself. A good body shop can do this part easily in subtle ways so it comes out right. The shop manual has some measurements of the geometry of the front end so you can check to see if it is tweaked. An amateur is likely to end up with it not fitting well so this is where you would do well to spend some money to get it done right (including pulling out the "frame" as necessary). When lined up just right, the fender is welded on using a wire feed or TIG to weld inside the holes in the new fender attaching it to the underlining structure. If the new fender has no holes, you can spot weld it if you have the machine (rent it) or you can drill holes and use a wire feed (also can be rented). Don't forget to slop some undercoat goop into the seam inside along the door pillar when you are done. The factory put black plastic bags of fiberglass in the hollow spaces behind the wheel well to dampen noise and you should replace those too.

**A later post, also from Dirk Nansen:** BAT usually stocks new fenders for \$150 which is a good deal compared to the hassle of getting salvage yard "clips" which you then have to break down, install, clean up and repaint anyway.

To remove the fenders it is not as hard as it appears. Any body shop can do it but it is doable at home too. Best approach is to get a spot weld cutter from your local body shop supply store. This is a set of drills with a spot facing "end mill" type cutter that cuts a ring around each spot weld. The key is DO NOT drill through the underneath structure. Just cut through the weld area on the fender you are removing. You need the underneath structure to weld the replacement fender to. You may need a file or die grinder to remove the rest of the spot welds on the underlying structure. Though if you do use a salvage fender from a front "clip", you can just drill out those welds which leaves nice 1/4" to 3/8" holes at each spot weld which makes it real easy to just lay the replacement fender over the old structure and the old weld bumps match up with the replacement fender's drill holes. Then you "rosebud" weld them back on (TIG or wire feed). Note that a new fender won't have the drill holes so the supporting structure needs to be cleaned up more.

You also need a die grinder to cut the regular welds back on the door post (remove the door which unbolts from inside). Also some spot welds on the lower edge behind the wheel well. Then use a utility knife to reach in and cut loose the undercoat goop on the inside holding the back of the fender to the door post. It is a little fiddly around the headlight structure and the braces under the end of the bumper cover (remove headlights and bumper cover too) but with some thought you should be able to figure out which welds to drill out or cut and which to leave. With a little practice, it can all be done in 15 minutes.

Do spend some time lining it up before re-welding the new fender. Best to have a pro do that unless you are pretty sharp about that sort of thing. The new welds should be kept as compact, small diameter as possible like the original spot welds and don't grind them smooth. Just in case you need to do it again later. Don't ask how I know this.

**A third excellent post, also from Dirk Nansen** I have done a few. Easier than it seems at first. You need a plug weld cutter which is a special drill bit. Available at better auto parts stores. It cuts out the first layer of the plug weld but leaves the underlying layer intact. The point is to not drill all the way through the underlying inner fender part. You need the metal there to weld the new fender too, especially if you are using a "salvage fender" from a wrecking yard. BAT use to sell new fenders, but rarely has them in stock. I always keep a few in the garage (seriously). Especially driver's side. Everyone wastes the driver's side first.

The doorpost part is welded with a regular welding bead and needs to be ground off with a die grinder or small cutting wheel. Don't cut off any more metal than necessary.

Some fenders have a couple screws on the underneath edge, some have tack welds. You need to cut out the welds, if any.

The tricky part is around the headlights and the bumper. You need to remove the bumper skin and the inner fender liner. Study the bracketry around the fender and the little bits around the bumper and can probably figure out which parts stay and which get the welds cut.

With a little practice, you can remove an XR fender in about 15 minutes. It helps to have a thin pry bar to kind of pry open the seam at each spot weld you drill out. Often there is a small tag of weld left even after you cut out the spot weld and you have to re-drill or just pry it till it pops. Don't bend the metal too much. A spring loaded punch can be handy to set a mark at the center of each spot weld so the spot weld cutter cuts out the whole spot weld (they come in specific sizes). The Karman plant where Ford had the XR hulls built uses very precise robots for welding on the fenders, so you if you use a "salvage fender", the welds will be in exactly the same place on the replacement part, which is why you don't want to drill all the way through the underlying metal when removing the old, damaged fender.

Also, there is some sort of undercoat/bonding stuff on the inside of the fender above and behind the tire that you have to reach up and cut from under/inside. Use a long, old knife blade. You will find some black plastic bags stashed up inside the inner fender space. This is not someone's drug stash. They are there to damp out road noise.

Installing the new fender needs considerable attention to alignment, especially around the gap to between the fender and the rear door. Both the gap and the alignment so the fender doesn't stick out or in relative to the door. There is some adjustment in the door at the hinges, but if the door looked lined up before, you need to line the fender up with the door and with the hood. Spend some time and get this right. Use a small body hammer to "adjust" the inner fender flange and the fender flange that welds to the door post to get the line up just right. It figures that if the fender got damaged, the inner fender part and the brackets may have been deformed a bit in the accident and may need a little massage to get them just right. This is where the body guys earn there pay (or not).

You can use sheet metal screws, small clamps, or for the pros, something called "clecos" (if you don't know, you just don't know), to get the fender lined up so you can weld it on. It is probably OK to use a lot of small bolts or even high grade sheet metal screws and poly sulfide bonding agent ("Thiokol" or 3M "5200") instead of welds. Or use standard auto body "seam sealer" on all joints to avoid rust in there. But if you have a TIG or MIG set and know how to use it, then you know what to do next. The door post and under body seam will need welds in any case (you probably could do it with screws or pop rivets if you got creative, but then you probably wouldn't need my help). If you weld it, clean the mating surfaces before welding, spray on a "weld through primer" and use seam sealant after welding.

Good luck, and be more careful next time.

- 
- Window (in Door) Replacement Tips by Tony Vissoc

**Q:** I need to replace a broken passenger side window. How do I go about pulling one out of a car in the junkyard and installing it in my car? Thanks

**A:** Passenger side window It's actually not too difficult. Let's see if I can remember this....

Remove door panel (duh). You'll need to remove arm rest and the opener surround. Plastic film probably still over door. Remove. Remove the window channel at the rear of the door (the latch side). Held in by one bolt, and clipped into the track it mates with above. Remove all of the trim that the window slides into, or against. All of it. I don't recall if you need to unbolt the door motor from the door, but you may need to. Here's a tip for re-assembly. The window has a metal channel attached to the bottom. This stays on the window, by the way. The window motor mechanism has two wheels that ride in this track. It is easy to get one side in, but getting the other wheel in seems mostly impossible....But....You can remove the wheel from the linkage. It pops off easily. Remove it, put it in the channel and then pop the linkage back on the wheel. You'll see what I mean when you have it all opened up. This job took about 1/2 hour, excluding the time spend sucking the broken glass out of the bottom of the door...Have fun.

- 
- Unlocking an XR w/o keys? By David Weiner

**Q:** Does anyone know how to get into a locked XR without keys. Mine plus the spare are locked inside.

**A:** Pry the screwcaps off the rear swing-out windows. These cover the screws. Unscrew, remove window, reach in and unlock. Simple no damage to car.

- 
- XR Hatch doesn't latch unless you slam it? By Ian Glyn-Jones

Check the stop rubbers on each side of the hatch. These wear down and can cause the hatch to rattle. Also, the striker pin normally has a plastic sheath over it take up some slop. These wear off and the latch will rattle. Have a close look at the latch assembly itself. When in the closed position, you may notice the latch is worn larger again, causing the hatch to rattle. Some of the later XR's had better latches and striker plates than the early ones.

---



- Fixes for a Rattling Hatch By Al Lawler, Roger Jones and Bill

**Q:** Any way to renew the plastic sleeve and get rid of the rattle?

**Bill:** I was able to find some shrink wrap type tubing that went over pretty tight and then took a hair dryer to snug it up. It worked .

**Roger Jones :** There are many types of Plastic Tubing around that can be used as a Sleeve.

There is thin walled stuff used for Vacuum Tubing, then the junk they use for high pressure fuel line, the tubing used in forced vent furnaces and water heaters to monitor atmosphere/ pressure pressures, small water tubing, etc. A lot of this stuff available at Home Depot and other hardware and heating plumbing type stores.... Think outside the NAPA.

**Al Lawler adds:** I can't speak to the adjustment of the striker, but a bit of black hockey (friction) tape around the post that the hatch lock grips will eliminate the annoying squeaks and rattles from the hatch...

- 
- Fender Liners from Taurus for XR By Brad Anesi and Steve Meyer

**Jeremy Hidy asks:** I remember someone saying you could use the fender liners from another car with slight modification. Does anyone recall what car it was?

**Brad Anesi replies:** 1st Gen Ford Taurus / Mercury Sable. Note, I'm pretty sure this was done only with the fronts. No direct experience - just passing it on...

**From: Steve Meyer:** I doubt that they could fit much worse than the ones that I have here now from Rapido. I am not having too much luck getting anything to line up and will likely have to work them over somewhat to make them work. For over \$100 a pop I would expect them to slip right in place.

- 
- VIN (serial Number) decoding ByMike Hughes

**Q:**Anyone have access to a system (Ford OASIS or similar) that would have info about an XR if I have the VIN ? I need to know if manual or not more than anything, but any info that anyone can get is much appreciated.

**A:** Unfortunately, OASIS no longer has 1989 or earlier vehicles in the database.

The VIN will not tell you about transmission. It will tell you about: Country of origin ( W), manufacturer (F1), type of restraint system (B), body style (T80), engine (W), model year (H), assembly plant (M), and chassis number (667585). The "0" is a check digit that is a function of the sum of the numerical values assigned to other digits in the VIN and can be decoded by a proprietary computer program. If the check digit is not correct then the VIN is phony.

- 
- Steering Wheel removal By SoCal Henry and Mohamed El Rouby

**Q:** Mike Mccreight asks: Any tricks for removing my steering wheel? My cheezy puller needs threaded holes. (besides drilling and tapping holes, that is :P)

**A:** Mike, pop the Merkur center face-plate (horn). Insert 22mm socket (If I remember correctly!), and remove center nut. Place ignition key in and unlock steering column. Wiggle steering wheel firmly about until it comes loose. (At the JY, you would have to break the retainer above the red trunk release as you would not have a key to unlock).

**A: Mohamed ElRouby writes:** Here's the tools and the trick:

Tools - 1/2 drive ratchet, 1/2 drive extension, 22mm closed socket, flat head screwdriver. Trick. Put the key to 'lock steering' position. (steering column now locked - note position of steering wheel turn) Remove the horn button w/ flat head screwdriver. Undo the 22mm nut. Now put key in running engine position (unlocked steering wheel). Pull or/and gently rock up and down on steering wheel towards you. It should come free. Once out, lock steering wheel again. Bolt on new steering wheel and nut, very tight but not TOO tight in the same position you noted above. Unlock steering wheel key and place in horn button. Drive. If all ok, enjoy. Done this at least a half dozen times.

- 
- Key miscellany and Key Code Location By Steve Walton

**Q:** I had ordered a key blank from bat and had the local dealership cut it. The problem lies in that the key will not work. Ford wants me to get another blank and let them try again. Ain't gonna happen. The funny thing is while playing with the glove box lock looking for the tx code, I found the key works perfectly in the lock. It doesn't work in the ignition, doors, or hatch though. Since



the key is junk anyway, I was going to hit it with the Dremel and see if I can make it work. Does the glove box lock use less pins? I'm trying to narrow down the areas of the key that need work. Thanks, Justin

**A:** If you don't want a key blank with a plastic head, I have the regular key blanks in stock. Did you furnish a key for them to cut it with or do you not have a key at all? If you don't have an original or working key, **the key code for the door and ignition is located on the passenger door lock cylinder**. Any reputable locksmith, not your local Wal-Mart or hardware store, should be able to cut the key for you. Hope this helps.

- 
- Scorpio paint code mistakes (paint tech service bulletin)

**Q:** Scorpio: BC2722890427

**PAINT** - Code errors on certification label - Codes 00, 05 and 0T are wrong. Correct codes are A0 for Formatisse Blue, A5 for Brabazon, AT for Nautilus grey.

- 
- Sikkens Brand touch up paint

**Q:** If you do buy more, be certain that it's Sikkens brand. Their clip book match is incredibly accurate. Other brands never seems to blend to properly match the Sikkens characteristics.

**R:** Good point Roger. It matches so well because Sikkens made the original paint for the factory. If you are repainting one you will get the best match by also matching the underlying sealer color which is usually white. Yes, I said to use white sealer underneath a black topcoat. It does make a difference.

I have only checked a couple of cars but they have all had a white sealer under the color coat. I'm not sure they all have white sealer but you can check easily enough.

## Braking systems and Upgrades

---

- Some notes on the rear brake conversion by [fmrpro@yahoo.com](mailto:fmrpro@yahoo.com)

Just wanted to let everyone know I received the part from the Well, I got my rear disc conversion working. Great and much thanks to everyone who came up w/ ideas on getting a firm pedal. I've finally got a fairly firm pedal, but its low. Stops well, but can't lock them up. Much prefer a high and hard pedal, so maybe I'll be looking for a different MC setup w/ much larger bore. Any ideas? Drove this on a 450ml round trip to Tahoe, and was pretty happy except for the low pedal.

Okay, the records: 1)most attempts at bleeding (est. 14); and, 2) most major brake fluid spills/leaks (4). And I presumed I thought I knew what I was doing... Murphy's Law, paraphrased, "If anything can go wrong, expect it to, and be prepared." Please refer to my earlier posts for some problems to avoid/expect. ALSO, some of the things not listed in the MerkurEncyclopedia discussion, but which I found out for myself, or others tipped me onto (sorry if I didn't list names, but THANKS!!!) - hope this helps all who haven't done this yet:

- 1) Get a converted hose screw w/ bleeder screw threaded into it - the channels in the TBird caliper allow a persistent air pocket that you can't get out completely, even if you take the caliper off & rotate it so the reg. bleed screw faces upward;
- 2) David Godfrey's advice was to simply undo the hose screw and bleed off air at that point: very effective, not messy, and it works;3) Screw in the parking brake to take up slack before you bleed; this will squeeze the pads closer together, saving you a bunch of time;
- 4) If you dismantle the proportioning valve to clean it out in hopes of reusing it @ a steeper angle, it will be a PITA to get the air out, even if you twist it so the outlet screw faces upward. I finally gave up, disconnected it, and found two major air pockets; I ultimately bypassed it completely (sorry Bill...);
- 5) If you, as suggested in the MerkurEncyclopedia, just gut the proportioning valve and leave the lines intact ("that's how they did it in the SVO Mustang..."), you'll be in for a messy surprise: the valve has an air weep hole that outlets to the attachment bolt channel, to modulate heat/air pressure in the proportioning valve. This will leak severely. If I had the time, I'd weld it up, but it was much easier to just hack off the lines and union them together.
- 6) If you have to cut lines or redo etc., use 3/16" compression unions; use a dremel cutoff wheel, use a magnetic wand to get rid of shavings, and file the cut off smooth; use plumber's hi-pressure paste to coat the ends & threads, and you won't have any leaks;
- 7) Once the lines are hooked up, DO NOT let the calipers clink/hit anything the tiniest amount or the pads and slider brackets will pop out; I've been a certified MB and Volvo mechanic, and I've never had as much trouble getting pads et al back into a caliper as I had w/ these. Can't wait for when I upgrade from the stock pads...
- 8) Unless you have a good buddy, or slave labor (a son interested in cars...) to do manual bleeding, beg, borrow or steal a diaphragm-type pressure bleeder!

All in all, pretty happy w/ the improved braking performance... much more Euro performance like than before. But, now have to solve the low pedal. AGAIN, THANKS TO ALL!!!

A long time ago, I replaced the stock rubber brake lines w/ stainless steel flex-lines. Oops - when I went to install the new Pegasus steel flex-line replacements for the hard lines on the trailing arms (from David Godfrey), the line-ends didn't mate up. Finally went to the hardware store and got flare unions, or a combo, probably 3/16AN -to-1/8 fpt, (can't remember what sizes). Again, hope this helps.

- 
- Foliotech brake caliper paint by Mark Durso

**Q:** I am wanting to paint my brake calipers and was interested in what others have used/where they purchased it. Is folia-tec the best in everyone's opinion? I have been unable to locate it locally, the last time a guy talked me into engine enamel. Worked great until I installed it and the first drip of brake fluid hit it! - Joshua

**A:** I used the Folia Tec system on my Merkur. Yes, it was pricey but it works really well. Because it is applied with a brush it is very easy to do. If you are not too picky you can even leave the calipers in place while you are painting them. The kit was more than enough to do put several coats on the four calipers of my car (I converted the rears). Spilled brake fluid didn't seem to affect the finish though I cleaned it pretty quickly.

- 
- Cheapest Quality Brake Rotor Source by Mike Mccreight

**Q:** I'm certain that this question has been asked and answered numerous times, but I'm looking for the best buy on front rotors XR4Ti.

**A:** Last I checked it was [www.nopionline.com](http://www.nopionline.com) Beware cheap rotors. You want Brembo/Eurorotor or better!

- 
- Cheapest Brembo Contour SVT Rotor Source by Tony Vissoc

**Q:** Found some at \$43.99. Is this a good price on these??

**A:** I'll say! Where did you find them at that price??

**A2:** <http://www.alloemautoparts.com>

- 
- Rear Wheel brake cylinder warning from Tim Lewis

Don't get a Wagner wheel cylinder... too big!! Had to 'file' the shoes down!!

- 
- Noise from the rear wheel by Mike Mccreight

**Q:** My 85 Merkur has a noise in the rear right wheel. Does anyone know what the hell it is? i had the bearings changed and the noise is still present. In fact, there is a lot of free play in the wheel. i need to know what this problem is. Thank you in advance.

**A:** Dunno if this will help. My 85 had an intermittent horrible noise from the right rear. I thought it was the brake shoe dragging or the e-brake had disintegrated 'cause the noise went away with application of the hand brake. After I had it apart twice I noticed a shine on the e-brake cable, and "machining" on the rim. The clamp holding the cable had rotted, and the cable rubbed on the wheel. Did I feel sheepish. I think you could hear this for about 6 blocks.

- 
- Shake and Brake by David Johnson and Rex Shultrich

**Q:** After 4 years of XR4Ti ownership, I am now on my 3rd pair of brake rotors. I recently replaced my TCA's (with new bushings in them, of course), and still experience the shake n' brake problem.

**A:** On my car, it was the slider pins and especially the slider pin bushings. Old, worn, and dirty, they cause the caliper to drag a pad on ONE side of the rotor and that leads to premature death for rotors. I went through several sets of rotors and pads. I finally had the calipers replaced with remanufactured units (from NAPA). These came along with new slider pins and bushings, but I think that you can get those separately.

I also had a ball joint problem that resulted from the bad rotors. I fixed that problem by installing new Lower Control Arms and outer Tie Rod Ends (from BAT). Today, I have no shake-n-brake problems. Other problems - YES; Shake-N-Brake - NO. :- ) I don't think that the LCA's had anything to do with the shake-n-brake since I had decent LCA Inner and Bar bushings (3-4 year old GrpN bushings) and the new LCA's from BAT came with the new (but soft) factory bushings.

PS. My rotors also came from BAT along with my MINTEX street pads and SS lines too. I had the rears overhauled (kit from BAT) to get away from potential front/rear bias problems...but I think that the magic came from the slider pins-- be sure to lube them well!

- 
- XR4 Caliper differences by Lih-Yen

**Q:** I was ordering a remanufactured caliper for my '89 at AutoZone, when the parts guy asked me whether it's a '10mm clip' or a '1.5mm clip'. Does anyone know what this means?

**A:** I have the answer now.

There are indeed two kinds of calipers:

- 10mm clip (Autozone P/N C8698 / C8699 for right / left)

- 1.5mm clip (Autozone P/N C9190 / C9191 for right / left)

The sizes refer to the anti-rattle (retainer) clip receptacle size. The 1.5mm clip is for a spring wire. I understand that the 10mm clip is a changed design, and the receptacles are indeed 10mm dia. through holes, but I have not seen what this piece of hardware looks like. Search for Jim Wirt post on 2001/07/31, subject: "Front Caliper Heads-Up", although that pertains to a Scorpio, but, to quote Jim, "it is the same part."

My experience is if you order the complete, loaded kit, which includes the caliper, \_and\_ the mounting bracket \_and\_ the anti-rattle clip, it should not matter. But if you are ordering only the caliper, you should verify what is in your car.

---

• XR4Ti Brake Light won't go off by Jon Welsh answered by Greg Munizich

**Q:** Well, here's a new twist. My brake lights won't go OFF! Just happened in the last half-hour! I'm about to go crawl under the dash to see if unhooking the switch at the pedal (assuming there is one) will turn them off for now...Any suggestions on what might cause this are VERY welcome!

**A:** I had the same problem 6 months ago. It was the relay in the fuse box under the hood. It is easy to locate the one for the brakes. Pull it out and carefully pry off the square plastic cover. use a small strip of fine sand paper to smooth the contact points. I slipped the sand paper between the contacts and held light pressure that closed the contact on the sand paper and pulled the paper out. Repeat this until its good enough. This should fix it until you find another one.

---

• Cannot get rear drums to go back on by Mike Hughes and James Albanese

**Q:** I can't get the rear drums back on after doing a brake job. What's the deal ?

**A:** The lower shoe was thinner then the upper shoe from the factory. Back when you could get OEM rear brake shoe kits, the shoes were also of two different thicknesses and the thinner one went on the bottom. Now the after market brake shoe kits come with both shoes the same thickness. This results in too much lining material on the lower shoe and the drum is not going to go on easily, if at all. Turning the drum to make it fit will harm the performance of the brakes as the top shoe will need to travel way too far before making contact with the drum. The self-adjusting mechanism will eventually take up this slack, but then it will reach the end of its adjustment well before the brakes are worn down and then performance will suffer again. Plus, you've probably ruined a hard to find drum. Rear drums on an XR almost never need turning, in our tech's experience.

They also have passed along this juicy tid-bit: Many state inspectors will try to fail an XR because of "uneven brake wear" or one shoe being so much thinner than the other. This is the way the factory set it up! Every tech in our shop agrees that the rear brakes on an XR will last 100-150K, at which point the upper shoe will be thinner than the lower shoe! The best suggestion any of the techs at our shop can come up with to deal with this issue is to take the shoes to a reliable racing shop and have them shave about 30% of the lining from the lower shoes prior to installation.

**A2:** My relined Raybestos shoes are like the OEM, thin and thick linings. When I sat thin, I mean thin! ...James Albanese

---

• PBR Brake swap notes, real world Experience by Unknown

**Q:** I might be doing the DG brake upgrade tomorrow. I have all the parts listed on Ed Key's site and have read the directions as posted on Ed Key's site numerous times so that (hopefully) all goes easy. Anyone have any problems or things to add to these directions?

**A:** Are you doing the master cylinder too?

Here are my experiences:

Front:

- I used PBR calipers and they did not clear any 15" wheels that I had.

- Easiest swap, but use loctite on the bolts. DO NOT trust them to stay tight with the nuts/hardened Allen bolts.
- If you use the earl's adapters there is not enough room to use the stock stopnut on the fitting on the car end. They are not long enough.

Rear:

- if you use straight adapters on the car end, you will have clearance problems with the rear spring. I bought two very expensive -3 90deg adapters to solve this problem, but you can get away with the straight ones.
- the calipers are very hard to bleed. On the SSB kit, they include special banjo bolts with a bleeder in them. I just turned the calipers upside down and bled them that way with a wrench between the pads.
- PB cable routing is funny. You may have to do it 3 or 4 times to get it right.
- those calipers are not the world's best design. Take the time to rebuild them or get rebuilt. I tried to be cheap and one was frozen.
- I had some issues with the parking brake cable attachment to the calipers, I actually used a stock drum brake shoe retainer as an adapter for the end of the cable. This might be because I used 1989 Tbird rear calipers instead of 88.
- I gutted the stock prop valve the first time, and replaced it with a straight 3/16 inverse flare coupler the second time. To gut the stock one, take the lid off, remove the ball but do not remove the shuttle/piston.

Master Cylinder:

- Flaring and bending the lines is a PITA. I got some pre-made lines for one end and flared the other. I hate flaring lines anyway, so you might not have a problem.
- You must use the late (87? up) booster. The early one will not work.
- the connectors for the light are easy to adapt.

Overall:

My car now STOPS like I want it to. I can make the CD player skip if I want.

Bias:

- the bias is just a little too heavy to the rear, but I do not have any prop valve in the rear line. I think that a cheapie from Summit racing would cure that problem but I have not ordered one. I have used them in the past, and they are pretty good. You might not need one with the iron thunderbird calipers.

- 
- Using Speedbleeders to bleed XR brakes by Richard Thompson

**Q:** Can someone give me the basics for bleeding brakes ?

**A:**

Strategy:

1. fill reservoir with new brake fluid.
2. drain fluid from brake lines by opening the "bleeder" screw at each brake.
3. refill reservoir.
4. drain fluid
5. refill reservoir.
6. drain fluid, till it runs clear.
7. Lather, rinse, repeat.

The tricky part is not letting air go back up into the lines when the fluid comes out. This is where the Speedbleeders are magic. They are little check valves that screw in in place of the stock bleeder screw. They stay on the car, and the stock ones go in the trash. You tighten the speedbleeders down after bleeding, so you are not depending on the check valve for anything.

Sooooo.....

Jack car up. Use jackstands and normal precautions. Take off a rear wheel. Find bleeder on

back of drum backing plate. Unscrew it and remove it. set container under brake to catch fluid. It is bad for paint and eats some plastics. I usually dispose of it by mixing it with old oil for recycle.(for any lawyers out there, this is said in jest... ;P )

Take old rear bleeder to Autozone or equal. Buy a pair of SB1010 speedbleeders for the fronts and find an equal for the rears (the one in your hand) I think their "book" is wrong on this part. They are \$10 per pair, more or less. Buy bottle of brake fluid. also, [www.speedbleeder.com](http://www.speedbleeder.com) Rear speedbleeders are Motormite (Help) part number 13906 - M10-1.0x35mm brake bleeder screw.

Stop at Home Depot and buy about 3' of clear tubing that fits tightly over the bleeder end. This is to direct the old fluid into a container and since its clear, you can see old fluid, bubbles, etc....

Screw in the speedbleeder in the hole in the back brake. Run it down tight, then back off a few turns. Shove hose over then end. Drape the hose so that some fluid is trapped in a low point and does not freely drain into the container. This is to save a "sample" so that you can monitor progress.

Hop in car and pump brake about 5 times. You are pumping old fluid out, and its being replaced by new, clean fluid. Stop pumping. Check fluid level in master cylinder. Top off. Pour slowly so as not to make additional bubbles. Do not pump it dry or you start over. Its easy and fun to have a helper pump the brake while you watch the fluid. When it runs clear and no bubbles, tighten bleeder all the way down, and move to other rear wheel. Then, do the fronts. Start with right rear, then left rear, then right front, then left front.

Pedal should be rock hard. If not, do one more round. Make sure there are no bubbles.

Actually, I don't jack the car up, I just slide under, now that I think of it.

Have fun. Its really not bad at all. Total cost is \$25, or so. Shop charged me \$70 and did a chitty job. Now its easy to change fluid again next year. Reuse bleeders.

Take care,  
Richard

=====  
• Clicking Sound from Scorpio ABS Module When Brakes Are Applied by Ed Lijewski  
That clicking is not normal, has nothing to do with the accumulator or the ABS pump of any other ABS part, and is an early warning signal from one of the ABS relays behind the dash that it's dying. It may survive for some time in that mode, but only replacing it (replace all three relays in that block behind the dash) will deal with this issue. Doing that eliminated the clicking from that area in my Scorpio that suddenly appeared one day. Removal of the dash is a bit of a PITA just for that purpose, unfortunately.

=====  
• Where are Scorpio ABS fuses found on the car by Ed Lijewski

**Q:** I am having some difficulties with my antilock brakes and wanted to do some experimenting. Does anyone know where the fuse or the relay for the antilock brakes are located. I looked in the fuse box and it was a no go there!

**A:** ABS relays are mounted under the dash on the center/passenger side; remove the dash to get access.



## Buying a Merkur

---

**Q:** I want to buy a Merkur xr4ti in very good condition. Anyone have any tips on buying one please let me know.

**A:** Here are three excellent e-mails that were contributed by Richard Curtis, Bill Stobbe, and Chris Cleeland to the previous IMON list that I think will give you a great head start in purchasing your "new" XR.

- From: Richard Curtis

But, look for these things. Each is a serious bargaining point and hardly any is a reason to walk away from the car as long as you can do a lot of the work yourself. If you have pay a mechanic to do any of these, you're probably talking serious money:

- Air Conditioning. Fixing XR a/c is very expensive. If yours doesn't work, deduct some serious dollars. Check the long hose going from compressor to expansion valve (runs right above the turbo). If cracked or aged, it'll cost hundreds to replace. If compressor is shot, very, very expensive.
- Does the fan work on all three speeds (low, medium, high)? If the fan works only on high speed, and you're dealing with an uneducated seller, this is a very good bargaining point because it's an easy and cheap fix.
- Cracked leather upholstery, or split seams. Very expensive to fix.
- Check the exhaust manifold for cracks, especially between cylinders No. 3 and 4. Very common. Not too expensive to fix but a real pain.
- Steering wheel shudder when stopping = either warped brake rotors or worn lower control arm bushings. Fairly easy to fix and not too expensive but a tremendous bargaining chip.
- Steering wheel shudder at all speeds = very expensive fix. Bad inner tie-rod ends and/or shot wheel bearings.
- Rusted exhaust system. Expensive.
- All coolant hoses.
- Check that the heater works. If not, it could be very, very expensive to repair (new heater core) or relatively cheap (flush the heater core and/or replace the heater control valve).
- Leaking taillight gaskets can cause water in the luggage compartment (pull up the carpeting and check, especially the spare tire well. Easy and inexpensive to fix but the seller might not know that.
- Sagging headliner. Looks terrible; tremendous bargaining point. A do-it-yourself repair (covered in Archives) that can be done for about \$50.
- Inoperative turbo (loud whining, sometimes notable police-siren-type noise) can be very expensive repair.
- If automatic transmission, can be expensive to repair. Check for leaks. Check fluid for proper color and smell (if it smells burnt, run away from the car; if it's any color other than cherry pink, run away).
- If manual transmission, it should shift cleanly, without noise (crunches, graunches, rattles, etc.).
- Clutch should be in good condition, of course. If not, deduct some serious dollars.
- If you experience vibrations at speed, probably needs any number of things: guibo, suspension bushings, etc.
- Does the body sit level, or does it sag (needs new springs, shocks, etc.).
- Check for uneven tire wear (alignment).
- Engines are generally bulletproof if not overheated. If engine temp gauge doesn't work, deduct some dollars from the asking price and be very wary of a bad head gasket. Check for water in the oil (not a good thing). Engine should not generate either black or white smoke.
- Turbo boost should reach 15 pounds in automatics, 18 pounds in manuals (is that right for autos?)
- Check condition of power steering fluid (it will probably be black and watery-looking. Fresh fluid is pink. Check for notchiness in the steering. Sometimes this can be cured by simply flushing and refilling the power-steering fluid but sometimes it means a new steering rack (several hundreds of \$\$\$).



--Don't be surprised if all the warning lights on the dash flash on and off without reason. Almost all of them do this.

--If the car has obviously been well cared for (clean, in good repair, etc.) expect to pay more than one that has been neglected (dirty, unkempt, things falling off or wired on).

--Faded paint, especially on the rear wing in pre-88 XRs.

--Batteries do not last long in XRs (a year? two years?) so expect to be buying a battery soon.

--Find out when timing belt was replaced. Should be replaced every 60k.

--Clicking from the rear wheel area while driving slowly with the window down = bad CV joints. This is another bargaining point because it's fairly common among high-mile XRs AND it's a repair you can do yourself if you have patience and an endless supply of Torx bits.

--Among things you may have to fix/repair: vacuum lines, fuel-pressure regulator, fuel pump(s), injectors (if leaking; check for puddles of gasoline on the fuel rail/intake manifold), oil/fuel/air filters, bent wheel rims, leaking valve cover gasket, gummed up Idle Air Control valve, EGR valve, clean the throttle body, replace PCV valve, fan belts, timing belt, spark plugs and wires, distributor cap/rotor, TFI (you should carry a spare TFI anyhow)(only buy the Motorcraft version = \$80+), instrument cluster illumination bulbs, sluggish tachometer, inoperative or erratic fuel gauge, broken emergency flasher button (it should be red atop the steering wheel column), inoperative power window switches (usually just need the contacts cleaned), cracked dash (figure at least \$100 to fix it, no matter how you do it)(almost all 85-87 XRs have cracked dashes), replace the coolant cap immediately after buying the car, don't expect the automatic radio antenna in pre-mid-87 XRs to work.

--Extra points if the seller has a fire extinguisher already in the car.

- From: Bill Stobbe

The big things for me are general maintenance and upkeep. I always go for a car that has signs of good upkeep and has receipts to prove it. Look at the body panels, if they are rippled, or you can see where they don't match, or if the car was just recently painted this may be NG. Bad bodywork can not be redone, and a recent paint job might mean a cheap cover up of rust to sell the car. Though recent paint which looks professional and is receipted is probably ok. You could visit that body shop and make a check of the cars that they are working on. How do they work, slock artists, they won't give you time of day or are not proud of what they put out the door? Common sense is a good guide with any car. Look at the trunk and door bottom lips to see if they are rusted out.

A low mileage original car is good in my eyes, although they are getting harder to find. Next choice, a car which has been maintained well by an owner who likes the car, regardless of mileage. Take Paul West's car for example, it looks like it just came from the showroom, and has 100k+ miles on it.

Also, I don't like receipts for non-ford parts to be used, but sometimes I have to accept that. E.G. If the history has parts installed from cheap manufacturers, say Monroe shocks, or Midas muffler, this knocks down the car in my eye. I know they will fail sooner than OEM parts.

Do you have clutch or auto tranny rebuild receipts, this is usually required for clutch between 70- >100k mi, and my 5-spd trans lasted 115k mi. Don't know auto trans info.

Also look at the color of the brake fluid, oil, and steering fluid. They should be clear, not muddy or black. Dark brake fluid means they never changed it, and you may have leaking brake cylinders in the rear, and possibly calipers seizing up front before long. Same with wear on the engine and steering gear.

I always want a car which has no leaks. Check the oil, steering fluid, brake fluid etc. You can see evidence of this where the car is normally parked, or if you park it after running. Look underneath at the car on jackstands or ramps. Does it look clean and dry? Leaks have 2 problems. 1st, they make messy work areas when mechanics want to do anything. So they do work more sloppily.

Also, you get drips etc on the pavement. 2nd if I forget about the leak for awhile, the component which is leaking undergoes extra wear because it doesn't have enough lubricant. Every car I have bought has had a leak in the steering line where it is mounted to the frame. (black rubber hose)

Steering gear normally has a slight whine when the wheel is turned, should not be loud, but barely discernable. Like your car idling, you can hear it if you listen, but a leak in the exhaust makes it noticeable, same w/steering.

Car should pick up without hesitation, idle at a consistent RPM. Look at the seats for broken stitching. This is more common with leather cars. Figure \$200 per seat to have anyone good take off and re-sew the leather coverings. I think cloth has lower maintenance, although not as cool. ;-)

You don't have to be a guru to make a good general checkup. If you find a car which passes general checks, put out email for someone in your area who can come look at the car for you. There is a mechanics listing in the Merkurbahn webpage some- where for Merk friendly mechanics. Have the car checked by one of them maybe? A private owner is a good resource, someone who has owned XR4's for a number of years.

My XR4's have been pretty trouble free for the 11 years I have driven them, and they've always been my daily driver. They are especially fun in winter, go anywhere. Make sure you get snow tires on all 4 wheels, else they are a terror to drive in even the lightest snow. [unless you go reaaaal slow]

This list got me out of the clutches of incompetent dealers and mechanics, and into fixing my own computer managed car. I was afraid of the EEC-IV idea at first, and got to really appreciate it as time has gone by. A very trouble free system that is well-proven in Ford vehicles. Use this resource to it's greatest extent, a lot of good mechanics reside here. Oh, and may I mention, alot of great people too!

- From: Chris Cleeland

Personally, given the age of many of these cars, I would prefer to find a car that, instead of low accumulated mileage, has low average mileage. The worst thing you can do to a car over 5 years old, IMHO, is not drive it--it's like what doctors say about getting enough exercise.

So, rather than look for the holy grail car that has 10,000 original miles (and likely lots of dry-rotted and cracking stuff), prefer to look for a car that has been maintained, has mostly highway miles, and has a low number of miles on it for the age of the car. IMHO, low annual mileage would be < 10,000 miles/year, so for some cars even 150kmi wouldn't be out of the question (an '85).

- From Pat Hoogendyk. Southern Alberta Merkur Association

Look for:

- 1}Kick the tires.. how much movement, could need bushings or lower control arms...
- 2} Whining of the turbo
- 3}Smoke when start up cold, or knocking of bottom end
- 4}Rough idle could need TPS or new Air by pass
- 5}clutch
- 6}switches all work
- 7}fuel injectors leaking
- 8}radiator in good shape
- 9}windshield
- 10} rear main engine leaking
- 11}exhaust ok

- 12}Rear end leaking
- 13}bounce the front struts ad rear shocks
- 14} Rear hatch lock work
- 15}heater motor works on all speeds
- 16}interior in good shape
- 17}Rust behind the cladding
- 18}rubber driveshaft guibo ok
- 19}wheel bearings..
- 20}brakes
- 21}Rear CV joints and boots
- 22}power steering rack boots and inner and outer ball joints
- 23}rear windshield wipers work
- 24}gauges all work
- 25}coolant leaks

If all pass or at least 75%...should be a descent car....these cars done right can be very enjoyable and be very reliable...i would drive from Canada to California to Florida in mine ,well after i put new tires on it and a wheel alignment from lowering it...

**Don Spence Asks:** Hello All I'm new to the list. Live in western Canada, looking at buying a Scorpio and would appreciate feedback as to why I should or shouldn't. In particular is there a checklist of things to watch out for? Particularly the expensive ones. Are they reliable or is owning one like owning an old English car?

**Ken Kizer replies:**

Nicely designed German vehicle. I was surprised how much room there is around the motor to work. The main problem is they're just getting so old now. Not many prime examples left.

(High maintenance)

Well, part of the reason they're not still being sold was the high price. But they include most of the extras. This adds to the enjoyment, and to the list of items to watch.

What is life expectancy for major components like engine, trans, AC system, Electrics etc.?

Lower end of the motor is bulletproof; heads are prone to cracking if run hot. They also used it in the Bronco II's and Rangers. Parts are easy to find.

Transmissions suffer, too, if the motor gets too hot. Generally, though, they're fine.

A/C system is average to good in reliability. I've switched mine over to R134a without modification. Throws slightly smaller ice cubes now...

Blower motors can go. Kind of a pain to replace.

Electrics are okay, in general. It's just that there's so many electrical options/relays/wiring. Get a factory manual- there's no substitute- and a code reader. These two items save a bunch of time.

Gauges can be finicky. Sometimes it's a cold-solder problem. Speedo uses an electrical sender.

Power steering often builds up shellac on the rack- steering is 'notchy'. Various fixes for this.

Rear defog switch is often fried, because, for some strange reason, it wasn't wired through a relay.

Leather seats are often worn by now.

Driveshaft rubber donut and transmission mounts are common wear items. Still available for less than \$100 total.

Headlights turn yellow... various methods to clear them up.

Run premium gas if you get it. You'll get a little better mileage.  
Mine knocked some with regular.

I've been looking at one with a leaking ABS module.  
Big bucks?

Not necessarily. Several European makes use the same system. More commonly, the ABS light stays on... it's a fussy system.

As you can tell I know little about these cars, but I am intrigued.

Lovely vehicles, if you start with something in good shape. They aren't bluffing with that 150mph speedo.

They can also nickel/dime/dollar you to death if it's not right. Cuts your cost way down if you do your own work, even more if you can find used ones in the bone yard.

I have two- the first one was accidental, the second one I went looking for. At best, I get ~28 mpg on the road, ~22 around town.

## Cooling

---

- Coolant Temperature senders (see Sensors for additional info)

**Q:** Do you need to specify a purple ring sender when buying an aftermarket coolant temperature sensors ? Aren't all the current sensors sold for the XR built to the purple ring specs. ?

**A:** I replaced them in 2 of my XRs with aftermarket units. Both cars now read high all the time (I have since read of others with this problem also.) My recommendation is to ONLY use the purple ring unit unless you don't mind "normal" being right at the bottom of the red on your gauge. ---  
Joshua Lawrence

---

- What to do about a gurgling car Radiator by Bill Stobbe

**Q:** I've developed that most annoying merkurism. Every time I shut the car off she feels the need to purge her coolant system. Does anybody have a good local source for a new coolant cap???

**A:** Interesting you should bring this up. My '87 was spitting coolant when I arrived at Carlisle. It also boiled antifreeze after turnoff. I had just bought a new cap from NAPA, but both old and new did the same thing.

I talked to Nick Mannarino of Modern Performance at the show. He told me that the Stant catalog has the wrong part # for XR4TIs, and checked my cap. When off it's center plunger under the rubber drops down and isn't spring loaded. (You are holding the cap right side up :-)) This is the WRONG CAP. The one you want has a small 1/2" spring loaded center thing which is spring loaded as you pull down. So it sits up against the rubber on the of the cap bottom. Nick mentioned that bad one is for an "open" system I think.

Anyway I went to AutoZone with Jim Gosses on Sunday and checked. They gave me the wrong part # there also. Both parts at NAPA and AutoZone listed the bad part. I got one per Nicks description and voila, problem gone.

BAD PART: Stant 10331 [16 lbs pressure, vented]

GOOD PART: Stant 320 [16 lbs pressure, no vent]

Note, there may be other bad numbers, as Stant sells both vented (lever to release pressure) and non-vented caps.

Change it and your problem will be fixed. Thanks greatly to Nick for the diagnosis, and Jim for taking me to get the new one.

- Additional part number by Chris Senior

FWIW I put a new Radiator cap on my XR last night. I bought a Stant PN 230 (10230) for like \$4.00. It was the perfect match.. Non vented. No more gurgling.

- Additional part number by Davis Stewart

I have a 331 vented cap and it works fine.

---

- Removing air pockets from the cylinder head by Jon Welsh

**Q:** My car is overheating, the radiator fluid is backwashing back in to the tank once i shut my car off. The tube also shakes while it does this, and steam comes from the radiator tank. What do you guys think is the problem? Besides that BUFFALO HIT 90 DEGREES!!

**A:** Sounds like you're making steam in the head. Looks like you got some other good suggestions on the List, but you might also try this:

With the car cool, fill the cooling system with a 50/50 mix. A little Water Wetter is never a bad idea, either. With the cap off, start the engine and let it warm up enough so that the thermostat opens (the top radiator hose will get warm when this happens). The let the engine continue to run for AS LONG AS IT TAKES for the stream from the small hose into the reservoir to become constant. By this I mean you need to wait until this stream stops being intermittent; stops sputtering & spitting; etc.; sometimes this takes quite a while, and sometimes you need to increase the engine revs a little to get it to do this (depends on your water pump volume). If the level in the reservoir drops while doing this, continue to add 50/50 coolant to keep the level [at least] above the "minimum" mark.

What you are doing is purging air out of the head... There are a few places in there that are higher than the cooling system, and there are some places that just DON'T want to purge. And if you leave any air in the head, you will have a cooling system that can't pressurize all the way (air compresses; water doesn't) regardless of how good the rest of the system is. If the car

belches after it's been shut off for a few min (either just into the reservoir, or right out onto the ground), and if it blows steam into the reservoir, this confirms that there is still air in the system; probably in the head... The air is both expanding as it gets hotter from the heat sink with the engine shut off, and because it is keeping the system pressure down, it may be allowing the coolant to boil in the hot spots in the head.

Give it a try... The results are amazing, and I know that most of us (and most mechanics) don't do this as thoroughly as we should when adding coolant. It's 96 here now, at 4:30 PM, and I hear it went over 100 earlier. No overheating or gurgling problems in my '89, despite having a known "sludgy" radiator that I intend to replace this weekend.

- Alternate Radiator Source by Dave Baylor  
Here's some information on radiators available from Fisher Radiator in Mars, Pennsylvania. Don Fisher is the owner. 724-625-3370. Great place to do business!

Hello Dave,

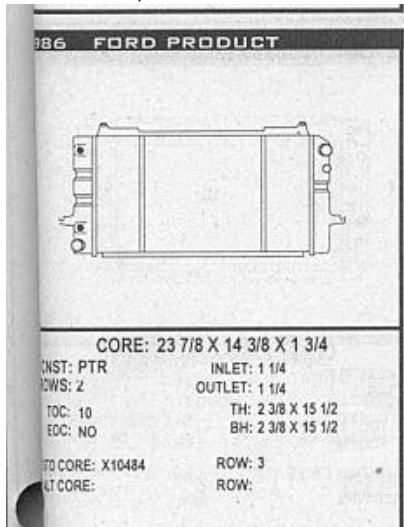

Above radiator # UAR-986  
Automatic Transmission  
Price - \$204.00 which includes UPS shipping via ground.  
Warranty - LIFETIME  
In Stock

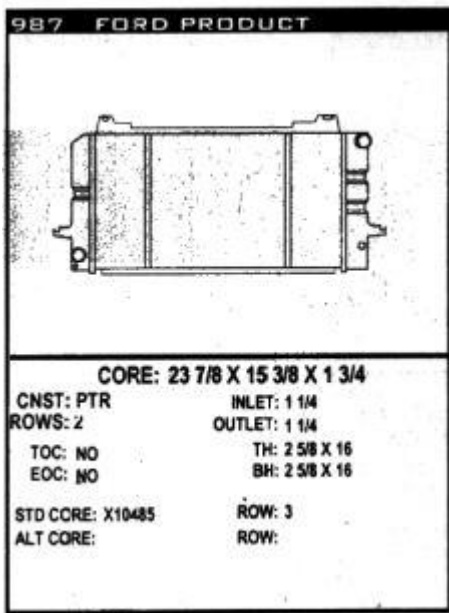

Above radiator # UAR-987

Manual Transmission

Price \$191.00 which includes shipping via UPS ground.

Warranty - LIFETIME

In Stock

If interested please use secure order form located at [www.heatercore4U.com](http://www.heatercore4U.com) and put radiator number and price in comment box.

Thanks...Don

Fisher's Radiator Service

Don Fisher

[www.heatercore4U.com](http://www.heatercore4U.com)

- I got one from radiator.com. It was pretty close. The only problem was drilling a few holes for the electric fan mount. Good quality, though. Scott Skinner

=====

- **Radiator cap for 89XR** by Stephen Roberts

My symptoms: even with new radiator, thermostat, etc., etc., car was running consistently hotter than my 87. Radiator fan kept coming on after only a minute of idling at stoplights, and the gauge needle always ran at the 3 o'clock position. The overflow bottle was always above the HOT Full mark, and sometimes dangerously close to the radiator cap. Dave Planakis correctly diagnosed the condition as the radiator cap not holding enough pressure. Installed new radiator cap, all conditions now back to normal

**A:** Jerry Chandler writes: I found that the perfect match screw-on style fill bottle cap is actually from Ford for under \$10. The cap from the 1998 Contour is a perfect match, except that it is black and not yellow. I can't recall the exact price, but it was less than 10 bux.

**A2:** Stephen Roberts adds: Same here. A new cap solved the problem. Also, I thought I remembered that the same cap may be used on Contour, but I could be wrong. Another possibility for not holding pressure could be small cracks in the seam of the plastic reservoir tank. Depending on the water level in the reservoir, you could get a pressure leak without losing much water.

**A3:** From Jon:, The part number for the cap is 703-2468. I got it from NAPA. It's the same as the cap for the 2001 Taurus 3 litre. This thing looks VERY different from any cap I've seen on a Merkur; it has a \*huge\* flange around the base of it that interfered with the hose clamp on the top, small, hose into the coolant tank until we repositioned the clamp. But looking inside the cap at the sealing area convinces me it is a much better design internally than the Ford screw-on part. No flimsy rubber gasket that will be in direct contact with the neck of the tank (so cannot be stretched out of shape by tightening and loosening, which is how the Ford part fails prematurely). So far so good; stopped the occasional burping-up problem instantly.



Since this is a very old thread, a reminder for the rest of you: This cap is to fit the '89 XR coolant tank, and is a screw-on cap which \*may\* be the same as those used on Scorpios but will not fit '85 - '88 XRs.

---

- **Radiator isolator sources** by Clem and Andrew Smutniak

In McMaster-Carr under the "Vibration Control Mounts" section there are "Rubber Sandwich Mounts." I believe these are known as lord mounts to some in the aviation and racing worlds. At any rate, McMaster-Carr's style number 3 has a mount that looks similar in dimension to the ones on our upper radiator mountings. They are available with Metric threads on the studs as well. The part number that I believe would be best for our application is 9376K115 and you must specify Metric and also whether it should be natural rubber or neoprene. (I'm not sure what would be best yet) I put these on the car this weekend and they are a very good replacement. The studs are marginally longer than the piece that came off of my car, but that should have no adverse affect (I'm talking about 1/16" or so). The price from McMaster-Carr: \$1.30 each. **ALSO:** The rubber insulators are an inexpensive **Volvo** part. #1228599-5. Around \$4.50 each.

---

- **Cooling fan operation** by Richard Curtis

**Q:** Why doesn't my fan work now? It worked before I replaced the radiator. Now it doesn't. The fan itself works if you apply voltage to it.

**A:** Check the wiring. The radiator fan is controlled by a coolant temperature switch on the backside of the lower intake manifold (there are two sensors there... the upper one controls the dash temp gauge, the lower one – and the one more difficult to access – controls the fan). Check that the wiring connector hasn't come loose. Not that it should have when you changed the radiator but you never know. The coolant temperature switch/sensor could also have died.

---

- **Alternate Replacement Puller fan for XR** by T. Rhinesmith

Okay everybody, hold onto your hats for this one. I promised Greg Larsen that I would post this e-mail. Here is the scoop. At 100,000 miles, I was concerned about how long one of the electric motors would last, so off to the junkyard I went. I was able to match up a comparable fan/motor assembly for the Merkurs. I hope you are all sitting down. A suitable replacement part is a 1988 Pontiac LeMans fan/motor assembly. Yes, I did say Pontiac. It turns out that the Pontiac LeMans did indeed use a Bosch fan for that year. Perhaps there are other years applicable? It is virtually identical, with the only difference being the three holes in the mounting bracket tabs. Just drill them out a bit, and they fit right into the Merkur XR4 fan shroud. No kidding. I have been running this replacement for about 100,000+ miles. I have my original fan as a backup when the replacement LeMans fan fails.

---

- **Small Hose makes for big coolant woes** by Steve

Sorry for the length of this post, but please read on if you are interested/plagued by this problem...

Here's my rather subtle scenario, which I have just experienced. On my '89, after driving slowly in traffic and shutting down, I would sometimes get bubbling and then some coolant would be released from the reservoir under pressure. The release was from the cap (this is an '89 XR4Ti with the screw cap). Prior to these events the gauge would indicate warmish, but certainly no overheating. The usual volume release was typically about a quart.

I got good suggestions from the list. I tried carefully refilling the coolant system and "burping" it. I purchased a new OEM cap. These didn't help.

I put a pressure gauge on the coolant system and extended it into the car, just to observe the pattern of pressure in the system. I initially thought maybe the cap was not holding pressure. The cap was holding fine up to the rated 16 PSI. The pressure under freeway driving was typically 1-5 PSI. It climbed under street driving varying anywhere from about 5-12 PSI. When I shut down the pressure would climb pretty quickly to 10-16 PSI. Sometimes under these conditions the cap would release and I'd lose some coolant, maybe a quart or so.

What did I do? The radiator was only about 3 months old, so I didn't suspect the radiator. I did notice through all this that the fan did not seem to be coming on very often. I felt it should be coming on more often.

I tested the fan by supplying 12V directly to the fan motor connector. Fan ran great.

I changed out the fan thermostitch on the intake manifold. No improvement. I partially tested the fan power circuit by pulling off the fan thermostitch connector and jumpering the connector. Fan came on and ran great. I changed out the thermostat. No improvement.

Here's the answer! I pulled off the small hose at the lower bottom part of the intake manifold. Almost no water came out. I stuck a coat hanger in the manifold fitting and quickly got a pretty good water flow coming out. Water seemed to flow pretty well from the hose also. I then filled the coolant and ran the engine and again pulled the small hose off, and let some water flush out. Then I reconnected the hose, and refilled the coolant.

I went for a drive. The first thing I noticed was that the temperature gauge showed a much quicker climb to operating temperature than I was used to. I drove around on city streets for a while, and then went home. I let the engine idle, and after a while the fan came on. Then it went off, I let it go through a couple of off/on cycles. No loss of coolant occurred.

Summary: I conclude that water had stopped circulating through the small hose on the intake manifold. It had gotten plugged by a piece of crud or something. This is where both the temperature gauge sending unit and the fan thermostitch are located. With the small hose fitting plugged, the water in the manifold was literally a sort of "backwater", not seeing the normal circulation of water through the engine. So, this body of water was slower to respond to temperature changes in the engine. The engine had to get hotter than normal for the manifold water to heat and cause the thermostitch to finally close, thus the fan was much delayed in coming on. This would cause the coolant to run hotter than normal, and so when shutting down there was that much less "margin" for the climb in coolant pressure.

I just resolved this about a week ago, so time will tell if this is the total answer to my problem, but for now I assume it is. Hope you can make some use of this information.



for the newer crimped-in vinyl boots as they last longer and leak grease less. BAP can get the new boots from a VW Combi.

4. Making sure the new joints are well sealed is the secret to long life. One tip is to seal the mating faces with non-hardening Permatex sealant. It is surprising how much grease can leak out of this seemingly tight joint. Also be sure the boot seals at the shaft. A good hose clamp is preferable to the hard to install little clamp supplied with most boots. Get the narrow BAP hose clamps similar to the ones used on Merkur radiator hoses.

5. One detail I would appreciate help on is the question of "phasing" of the two joints. I have noticed over the years that if a joint is a bit too tight or drying out the axle shaft will walk in and out as the wheel rotates. This causes a vibration in the rear end. There should be a favorable alignment of the two joints on the splines to minimize this effect. No one seems to have the answer. If you do buy assemblies could you check the alignment of the two joints and share what you find?

Welcome to the Interesting World of German Auto Mechanics,

---

- Halfshaft Lengths by Steve Meyer

**Q:** Can someone tell me [quickly] which side (driver's or passenger's) halfshaft on an XR is the long one and which is the short one?

**A:** ..I was just noting that on my rebuilt halfshafts. Incidentally, I just had mine completely rebuilt by ARI through NAPA and they did a nice job. ARI is the rebuilder for all west coast NAPA stores. They did not have any cores so they R&R'd mine in 24 hours as is their policy. The cost was \$40 each with a 1-year warranty.

Here are the ARI/NAPA numbers along with their respective location and length:

<u>NAPA#</u>	<u>ARI#</u>	<u>Location</u>	<u>Length</u>
8395	20081	Left	18-7/8 inches
8394	20080	Right	20-1/2 inches

---

- Wheel Bearing Experience by Marty

I had a nightmare with rear wheel bearings when the originals went @ about 60k. Replacements started squeaking about 10k later, had them re-tightened several times, then finally replaced them. 3rd set started to squeak within a couple hundred miles. Went through same tighten, re-tighten several times with those. FINALLY, brought it to another shop, they tore it apart & said couldn't find anything wrong & put it back together with the warning that they weren't familiar with XR's & couldn't guarantee they hadn't missed something. Drove to MP in NJ (for other work too), and no problems all the way down. They tore em apart & found nothing wrong, but said .... looks like the last guy that worked on it re-staked the nuts to make sure they didn't loosen up, maybe that hadn't been done on previous repairs. 20k later & still no problems. Pretty sure that was the problem all along, the nuts were loosening. They should be either re-staked or replaced with new any time they're taken off.

---

- Bearing part no confirmation by Various Folks

**Henry:** I picked up a set of Timken seals # 3743 yesterday and they are the same size as the Napa CR19647 for the rear outer. The Napa CR16518 Rear Inner Seal is close to Kragens CR16523 for The rear. Looks like the 3743 or CR19647 can be used for both front and rear, and that Napa & Pepboys have the correct part numbers as far as I can tell until I install them.

**Jeff Martel:** The front, rear, inner and outer wheel seals are all the same. The BCA/National Book is all messed up, they have the correct seals listed for the front, and the incorrect ones listed in the back! It took me a week to figure it out...

Rear Wheel Seals The correct BCA/National Number is 3743...all are the same...

**Tony:** Ok, so to summarize, The front bearings are the same as the rear. Inner and outer are the same as well. Seals for the front work in the back. Use the part number that is always specified for the front. I haven't torn into the mess yet, so how many seals do I need for each wheel?

**Henry:** The shop manual show only 1 front seal (capped), but 2 rear seals for each wheel. Also, two bearings are needed for each wheel.

**Ed:** Front wheels, inner and outer bearings, A-31

---

- Was does a bad XR wheel bearing sound like? by Lih-Yen

**A:** Hi, Kevin, call Car Talk, the Click-n-clack brothers, to see if they have some sound tracks recorded from caller describing it. :-)

Seriously, wheel bearing noise sounds like low pitched, uncomfortable rumbles. It varies with car speed in terms of the number of noise 'beats'. The beats are about twice per tire revolution. Roughly, at 10mph speed you will hear about 5 beats per second. At highway speeds you may not be able to hear it because it blends into engine, road, and wind noises, and because of the beat frequency is so high (relatively speaking.)

You can also check for wheel play. Put the corner on a jack stand, grab the tire by the top and bottom, and move it in and out. If you can feel any play either the bearings are bad (or, hopefully you don't have this, the spindle is worn.)

If coasting tight turns (engine idling) makes the noise louder, then suspect the wheel bearings, and the direction of the turn is the opposite of the problem bearing side.

But you can go ahead with the caliper and rotor work. Worn bearings aren't as bad a situation as brake problem. Usually from when the bearing noise starts to when the bearings go completely bad there is a few thousand miles. But I am not advocating procrastination; you should have them looked at.

BTW, while you are on the brake job it is a good idea to also completely bleed the brake fluid. Hope this helps,

---

- Wheel bearing changes over the years by Brad Anesi

**Q:** Turns out after cleaning all the parts and dry fitting, there is enough wear on the spindle that the bearings are a sloppy fit.

**A:** Hi, I \*think\* what often happens here is that the bearings get worn and loose, and then due to the play, you DO get wear on the spindle. I'm not 100% sure on this, and if I had it all in front of me, I could analyze better what's actually happening. I have heard of others having this problem though, so it's not uncommon.

On a related note, bear in mind that for the front, starting in **1990, the factory changed the bearing setup to an interference fit and** made the entire spindle assembly available as the only service part. This applies to both the XR and the Scorpio, although I've never been able to figure out if there is some way to externally identify these later parts. Not sure what they may (not) have changed on the rears.

---

- CV-Joint Torx bolt removal tips by Chris Cleeland and Richard Curtis

The correct size is Torx T-40. Standard bits available at Home Depot. I did this recently and the best bit I found was, surprisingly, at K-mart. Guaranteed just like Craftsman and Home Depot brands (I tried those also).

Be sure to clean the heads of the Torx bolts thoroughly and make doubly sure the bit is fully seated. You'll most likely need a long breaker bar and be sure to use copious amounts of FreeAll or similar for several days prior to removal. FreeAll, or PB Blaster: they are your friend. Also, smack the bolt heads dead-on with a hammer to help the penetrant penetrate. While wearing safety goggle, get some canned air (like from camera shop or computer place) and spray out the bolt heads.

Smack the bolt heads some more. Put the bit in and smack the back of the bit (this also helps seat the bit).

Be careful with long bars; I found it much easier to round off a bit. I got better results by holding one fist around the std. 3/8" ratchet head and, while laying on the ground under the car, using my

legs to push against the handle. It's contortionistic, but my legs are MUCH stronger than my arms.

Good luck. Just plan ahead and spray away, and you'll be okay.

- 
- Diameter of Diff axle flanges by Tim Roman

**Q:** I know someone has the diameter of the diff axle flanges stashed away in their vault of useless knowledge somewhere. Is it 100mm or 110mm?

**A:** The stock XR CV joints are 100mm OD, or size 13 in GKN lingo.

- 
- Replacing just the CV joint boots ??? by Paul West

Well the Scorpio has a new half-shaft. I never intended to put a used one on the car and don't know why someone suggested it. The job took 1.5 hours with the impact wrench and the cost for the new half-shaft was \$82 at Car-Quest.

Unless you are that short of cash that you'd prefer to buy two CV boots and grease for \$19 each verses spending \$82 on a complete half-shaft and save yourself the labor and cleaning of the old grease and boots - it's a no-brainer.

- 
- Replacing XR Wheel Studs by Rod in Spokane

**Q:** I need a few replacement wheel studs for my '86 XR.

I read in the old archives that contour studs may work. One old post said they were a little smaller base knurl diameter (which scares me) and other posts said they worked great. Does anybody have a sure fire application for studs that fit our cars. i.e., make, model, year type info. I'm not even sure what year contours came out. If there are other applications, such as a ford ranger or Mazda or something, I'm open to that too. I'm not too worried about if they're a little bit longer because I will probably be using open-ended lugnuts anyway.

On the subject of lugnuts, has anybody experienced any problems using the aftermarket lugnuts that have the large cone that's part of the nut? I mean as opposed to the OEM large cone that can act as a washer (and not gall against the wheel surface as you tighten it). I don't foresee any real problems with these, I just thought I'd ask.

**A:** Go to NAPA and tell them you want some 641-2166 studs. They probably won't have them but they can order them and most likely will arrive overnight. These are stock studs. Sorry, but don't have a sub for the nuts. Hope this helps.

**A:** '93 ranger studs are a perfect fit, and a mm. or 2 longer. Napa has them. Don't use the aftermarket nuts. Wrong angle (I think) and not enough surface area.

- 
- CV Joint failure modes in detail by Scott Shidel

**Q:** What's that noise ?

**A:** As someone who used to rebuild CV joints, I can say that if the guy who built the axles was his first time, he may have put the joint together wrong. The joint is made of an inner and outer race, 6 ball bearings and a cage. The races have grooves for the balls to slide on. These grooves are angled, and make a pattern like / \ / \ / \ . Some people who are not familiar with the joints attempt to assemble them with the tracks lined up. This is wrong, and if assembled as such the joint will bind. If the inner track for a particular ball goes one way, the outer track should be its mirror image and point the other way. To get the balls in should take a process of constantly manipulating the inner race to expose the next window in the cage. Also, if the builder found wear on the old joint, the common fix is to install a slightly oversize ball. This is not the precise science it is on engine bearings, and basically you build the joint for a particular acquired feel. It is possible that the builder set it up too tight, or did not polish the tracks enough in the race, or a combination of both. See, when joints wear, they wear in small sections of the track. That is the reason worn joints click on FWD cars, because when the wheel is turned the balls are using 100% of the track, and they bounce in and out of a wear pattern that is established by the suspension angle at cruise. Larger balls in a poorly prepped track could cause binding that has a significant bang when loaded, but it is not near as common on RWD cars. Usually about the only problem that really pops up on a worn rear CV other than builder error or a catastrophic failure, is vibration.



- 
- What lubricant to use for Differential by Mohammed El Rouby

**Q:** Could someone tell me the proper type\weight\amount of lubricant used in the XR differential? I am going to check the diff in my 87 XR this week and I would like to refill it with the right lube.

**A:** As per my expensive Cosworth workshop manual: Hypoid oil SAE-90 Ford specification SQM2C-9002-AA for the diff. Yep, just 90 weight hypoid oil. Both LSD and non-LSD use the same oil, as the LSD portion uses it's own non-serviceable viscous fluid, hence the use of GL additive used on friction-plate LSD diffs is not necessary or recommended. BTW, this is in contrary to what the Merkur encyclopedia ([www.merkurenyclopedia.com](http://www.merkurenyclopedia.com)) quotes in the 'Installing a 7" XR4x4 LSD diff' section.'

---

- Wheel Bearing part number for 88 XR4Ti by Unknown

Dave Marshall asked about the specific's of TIMKEN's SET 24 bearing's for the Xr4ti. Dave has suggested that the following be archived.....

Dave, You'd get one standardized Timken bearing with the Set 24. The inner and outer bearings are the one and the same..... This number is also good for the rear wheel bearings. So to do the entire car you would need a total of 8, Set 24's.

It seems that the rears under go less torque in the turns and I have had not to replace them in the '85 at 199K thus far.

Our <Timken> bearings are made in a < first melted, then refined> two step, ladel refined, degassed, then Bottom Poured Steel Ingot process..... This type of process insures that there are virtually no inclusions when compared to our competitors.... I work in the rolling mill and have toured and given many tours in the melt area, the refining areas, rolling area, and the conditioning areas of TIMKEN. I am familiar with much of the process and highly recommend the product... It's a family owned concern that is recognized all over the world.

---

- Differential fill plug replacement source by Daniel Matzke

Hello all, I have confirmed that the differential fill plug size on the 86 XR4Ti, both auto and manual tranny, is M20x1.5. NAPA had a replacement magnetic plug with rubber gasket in stock for around \$2.50. Just ask for an engine oil drain plug for 83 – 86 1.6L Dodge Omni or Plymouth Horizon.

## Driveshaft and Guibo

---

- Source for guibo by Andrew, Joshua Lawrence, and C. Holloway  
Andrew adds : ~~Here's the part number (BMW) for a heavy duty NYLON guibo from the M3/M5: 26112226527. Chris Senior posted this, and he heard they are supposed to be bulletproof.~~ **Heavy Duty Nylon Guibo does not fit !**

The standard BMW guibo part number is 002-26-11-1-107-832.

Just wanted to let everyone know I received the part from the place below as suggested. So if anyone should need one, this place was quick and sent it out with no hassles at all. This was the Goetz part, which was identical to the original, FWIW.

1909 W. Kingsley  
Garland, TX 75041  
972-271-3643

Part No. BMW 26111107832 (for BMW 733i/735i ) ~~\$38.00~~

Freight ~~\_\_\_\_\_ \$ 5.00~~

Total ~~\_\_\_\_\_ \$43.00~~

If you speak to Angel, he will know exactly what you need.

**PART IS NOW \$50 FROM THIS SOURCE,**

**David Reese says THAT BAP GEON CARRIES THEM FOR \$30 OR SO.**

---

- Another Guibo source by Jim Korczak  
FYI - most of you probably have already done this and know about this, but I thought I would share my experience anyway. Guibo was disintegrated on the '86 XR. Purchased the BMW Guibo, Part # 26 11 1 107 832 from Bavarian Autosport ([www.bavauto.com](http://www.bavauto.com)) via their web site for \$44.95 plus \$6.95 shipping via 3-day FedEx. A very pleasant experience and alot better than the usual sources.

BTW, carparts.com has them listed for the Merkur also, for ~\$68.

I was got a replacement from my local parts store yesterday. It was expensive (~\$91 including tax), but that is the price I had to pay for instant gratification. The guibo I got is the one Beck-Arnley lists for the Scorpio. The part number is 103-2103 and it looked exactly like the original except it was not in many small pieces...

---

- Rotoflex replacement by Dirk Nansen

Rotoflex (guibo) replacement is one of the really neat and arcane things that separate Merkur guys from the rest of the world. So when you complete this job you can feel special. But don't bother bragging about it as no one else will understand. That's another special thing about Merkurs.

Four tips:

First, mark the back end of the driveshaft and diff input flange it attaches to so you can reinstall it on the same spot. That makes a difference in vibration. You will probably have to disconnect the driveshaft at the rear coupling to get the new guibo on. Note that if, after you are all done and you still have a driveshaft vibration, you can sometimes reduce that vibration by violating this rule and rotating the driveshaft rear coupling to one of the other three possible orientations. That's how the factory does it. You need the rear wheels off the ground later on anyway so you should have the car up high on good jack stands for this project.

Second, don't push the front section of the driveshaft deeper into the transmission tailshaft housing (and bushing) unless you have cleaned off the rust and gunk that builds up on the shaft that sticks into the bushing as it can damage the seal. It builds up immediately behind the seal

(especially in salt country) and you need to push it in to get the rear flange off so try to clean it up before pulling the rear flange. Hopefully you can get the old guibo bits out of the way and they move it back a bit so you can clean it before installing the new guibo. And if you pull that section out of the transmission (not necessary), oil will come out. So at least don't be directly under it.

Third, don't take the metal band on the new donut (guibo) off till you have the bolts in or if they don't fit that way, take it off (cut it) and replace with a large hose clamp (or two or three coupled as one big one) which you can adjust to get the bolt holes to line up. Easy to do when it is the right size. I always use the hose clamp approach but I sure admire those people who get it on with just the band. By the way, the BMW part sourced from various discount parts houses is relatively reasonably priced but you can get one from BAT or Rapido too. Pretty much the same part.

Fourth, be sure to realign the driveshaft across the donut as in the shop manual NVH section. This entails clamping a small dial indicator to the driveshaft so the finger touches one of the bolts that go into the front section (which sticks into the transmission). I use a length of 1/4 inch threaded rod bent to lay along the driveshaft and carry the dial indicator at one end. Most dial indicators have a 1/4" mounting hole. A couple of nuts hold it in place on the threaded rod. A hose clamp or two holds the rod to the drive shaft. Cheap dial indicators (\$20) will work fine. Small ones are needed to fit in the tunnel above the drive shaft. Zero it out with that bolt rotated to the bottom and then rotate the shaft so that bolt is on top (180 degrees). Use a small mirror and a light to read it if needed. The difference should be less than 0.005 inches. Achieve that by shimming the driveshaft support bearing or the transmission crossmember. Usually the driveshaft support bearing needs to be moved down. Use washers as shims. Sometimes you need as much as 1/2 inch of them to get it right. If you have trouble figuring out which way it needs to move, just pull the shaft down or push up at the support bearing and note how the dial moves. If the motor mounts are ever changed (and they probably need to be) you will need to repeat this process so you might want to look at them now. If the oil pan is touching the cross member or the fingers on the inside of the motor mounts are all the way down in their slots, the mounts need replacement (and they cost about \$200). After getting it shimmed correctly, then do the side to side alignment the same way. Zero the dial with the bolt on one side and then rotate it 180 degrees to the other side and slide the center bearing or the transmission cross member to line it up. Then recheck the up and down axis. With this completed you are close to Merkur nirvana with a vibration free driveline (assuming the driveshaft isn't just bent which is all too common especially after blowing the guibo). And also you get to wonder why all the fuss about lining it up to within 0.005 inches when Colin Chapman, for one, used these same couplings for "U-joints" on the rear half shafts of several of his designs.....Good luck.

- 
- XR Driveshaft Lengths by Tony Vissoc
- Q:** Are the drive shafts used in automatic XRs the same as those used in 5speed XRs?  
**A:** The Automatic driveshaft is longer. The difference is the section between the transmission and the center support bearing. See picture here:  
<http://www.team-v.net/xrpics/autovs5spds.jpg>



---

- U-Joint replacement and center bearing parts source by Jerry Chandler

**Q:** I am finally in the process of removing and installing new half shafts, rear differential, rear diff support bracket, and driveshaft center support bearing. I understand that the drive shaft U-joints are staked, and these can be redone with conventional U-joint caps and c-clips. I was curious about the procedure to effectively test whether or not the U-joints need replacement. Since I'll have it out anyway, now's a good time to check it out. All suggestions are welcomed.

**A:** Yes, XR and Scorpio driveshaft u-joints are staked. However, Rockford Driveline (<http://rockforddriveline.com/>) offers replacement u-joints. Their replacement staked u-joints are held in place using a circlip on the inside (closest to the cross) of the u-joint cap. This differs from a typical u-joint that is held in by snapping a circlip into an undercut groove in the top of the u-joint bore. Their replacement u-joint has a zerk fitting so it can be greased and maintained.

Their parts listing shows p/n 430-10B for the Merkur Scorpio. When I last spoke with one of their tech guys, he could not say that this same u-joint would not also work for the XR. We need someone from our group to check dimensions of the XR and compare them to the Scorpio and/or to the dimensions listed on Rockford's part in their parts pdf at:

<http://rockforddriveline.com/Staked%20Ujoints.PDF>

<http://rockforddriveline.com/replacem.htm>

I have not been able to check this.

He said that removal of the staked joint was accomplished by either mildly grinding back the staked deformations or just driving the u-joint into and past the staking, or both. It doesn't seem to be very difficult. I don't recall ever having seen anyone in our Merkur groups report on doing this. Also, he said that the important point about the ability of their replacement joints to work was that the shape of the inside of the yokes be as 'square' as possible, rather than angled.. thus allowing for installing that circlip. When you see that pdf diagram, you will understand what he meant.

Rockford also sells the driveshaft center carrier bearing for the the XR and the Scorpio, same part, p/n 461-56.. internal rubber and bearing only, no housing. Old internals need to be pressed/pushed out of the housing and new one pushed in.

When I spoke with them earlier this year, the u-joint was about \$25 and the center bearing was about \$80. Those are really cheap parts to be able to completely renew the driveshaft for another 20 years!

I had spoken with a Randy (ext. 123). I asked him 'why' they offered this for the Merkur Scorpio. He understood that there had been a Scorpio owner connected with them somehow that did the leg work to get this part made. No one had done the dimensional checks to verify if it fits the XR also.

We need to have someone confirm that the XR u-joint is the same as the Scorpio (I suspect that they are). When you study the little dimensional chart, you will see the dimensional options. Hopefully Tom or someone else can endeavor in this task and report back.

## Dual Plug Head Conversion

---

**Q:** Is that is it possible to put a DP head on a 2.3T? What is all required to run?

**A:** You will have to modify the turbo block to take the crank trigger sensor, then get rid of the distributor because the DP head intake manifold will not clear it. Below you will find just about all I know up to this point.

This is a ever changing write up, so as time passes by new comments/instructions will be added.

The advance is controlled by the EEC4 by means of the sensor input, The DIS module sets the base timing (10 advance) SPOUT disconnected it's like magic. Hence there are no base timing adjustments.

First of all you need the following parts from a DIS 8 plug head 4 Cylinder 91-93 Mustang or 89-93 Ranger. Yet the setup on the 91-93 Mustang is the best.

- Crank pulley assembly has the hall effect rotor in the back of it. You will need a puller to remove it properly with out damage, they are in very tight. Then again some come out by hand. Front engine cover. This is the one that holds the front crank seal It has a special shape to fit around the crank trigger bracket.
- Crank trigger bracket/fasteners and sensor assembly to include wiring and connectors.
- DIS module and wiring harness.
- 1 Coil pack or 2 coil packs and brackets depending if you are running a 4 plug or 8 plug head.
- Also plug wires.
- Dummy Distributor plug. This is needed in order to drive the oil pump after the distributor is removed.
- Water pump pulley and alternator (serpentine).
- If you are not going to use the DPDIS motor intake (4 plug head) you will need a heat sink to install the DIS module so to dissipate the heat and don't forget to put some dielectric grease in between the back of the DIS module and the heat sink. Also the DIS module requires a good ground for it to work properly.
- Crank trigger bracket installation.

This is the hardest thing to do because it requires that two holes be drill and tap on the from of the stock turbo block also is best to do it with the engine out of the car and oil pan removed.

You will need to make a template of the holes for the installation of the crank trigger this is done by copying the location of the holes on a DIS block. You can use the lower passenger side front cover bolt holes on the DIS block as a reference since they are in the same location as on the Turbo block. I used a piece of Plexiglas to make the template, I trim it so it would lay flat on the front of the DIS block and with a drill I made the holes on the piece of Plexiglas. Then I lay it on the front of the turbo block and center punch mark the spots to be drill for the crank trigger bracket.

**NOTICE:** The #1 main bearing cavity runs very close to where the holes for the bracket go. So you have to be very careful when drilling or you will ruin a good block, you may want to let a machine shop handle it. I took a chance and did it my self with a hand drill. Once the crank trigger bracket is installed there is a air gap that has to be set just right for the sensor to work properly, from my experience as long as the sensor does not rub against the hall effect rotor there is no problem and it will work properly.

Also when installing the DIS block front cover it will be needed to remove the gasket from the front part of the oil pan, you will need to use sealer because the gasket is going to be too thick for it to fit properly or use the oil pan from the DIS block.

DIS and EEC-IV wiring.

1. Unwrap the DIS wire harness all the way to the "Y" at the DIS module (do not unwrap the aluminum foil wrap wires).
2. Remove 2 wires from the White connector Black(Shield ground) and Blue/Orange stripe(CID not used).
3. Remove 1 wire from the Brown connector Tan/Yellow stripe(IDM).
4. Cut Red/Green stripe wire from multi splice, remove White and Brown connector with the MAF sensor connector/wires.
5. Remove IAC wires from Gray connector, at this point you should have just the DIS specific wires only.

The following is a break down of the wire color as per function and pin location on the DIS module connectors.

Top connector (Black) wires 1 through 6.

- 1- Red/Green stripe start/run power.
- 2- Blue/Orange stripe CID (output to turbo EEC-IV not used).
- 3- Gray/Orange stripe PIP.
- 4- Blue PIP (Crank sensor input).
- 5- Pink Spout.
- 6- Blue/Yellow stripe DPI (to ground).

Bottom connector(Gray) wires 7 through 12.

- 7- Orange/Red stripe IGN Ground.
- 8- Tan/Blue stripe Coil.
- 9- Tan/Green stripe Coil.
- 10- Tan/Orange stripe Coil.
- 11- Tan/Red stripe Coil.
- 12- Tan/Yellow stripe IDM (TACH).

You may want to use the DIS wire harness Gray connector that has most of the wires necessary for the connection or delete it and just solder straight to the wires from the Thick film ignition connector.

Notice the power multi splice it is a lot simpler to cut one wire to the coils off and splice it to the other, also the same can be done to the wires that feed the Crank trigger sensor and the DIS module. I figure this would be a call on the installer. I prefer to feed power to the coils directly from the battery + post by using a fuel pump relay which is good up to 30 amp.

Case ground(Chassis) is achieved by the mounting holes on the DIS module on the left side of the module holding it with the black connector up while facing you. Note this ground has to be good otherwise the DIS module will not work properly it also will get extremely HOT.

Pin orientation is marked on the DIS module just pull the connectors out and you will see the markings 1 and 6 for the top connector and 7 and 12 for the bottom connector.

This is actually very simple once the DIS module wires are identified =  
SPOUT, IDM, PIP, DPI, CID, IGN GND, IGN PWR and on the EEC4 thick film connector = SPOUT, IDM, PIP, IGN GRN, IGNPWR START, IGNPWR RUN.



After this is done splice the wires from the DIS connector to their respective equal on the thick film connector. NOTICE; the CID wire from the DIS going to the EEC4 is not used since the EEC4 does not have this feature, but the DIS module needs it to calculate timing. The DPI wire from the DIS goes to ground or you could use a normally closed relay driven by the starter solenoid wire so it will open the circuit on START so to turn OFF the driverside coilpack just like the stock system does. I prefer to use a source of power to the DIS that is on both when starting and running instead of the thick film ignitions power feed wires. I used the power feed wire that would normally feed the stock coil. You will be able to trim the DIS wiring harness of some unnecessary length of wire once you figure the location you will install it.

The DIS module has to sense it is grounding two coil packs to produce the IDM (tach) signal. If you are going to run a single coil pack on a 4 plug head then splice the wires from the unused coil pack connector to the coil pack that is going to fire the plugs. This will fool the DIS module in to thinking it is running two coil packs.

The following are base timing adjustments that need to be done when using the DPDIS 8 plug setup in order to achieve better performance and the capability of running higher boost level that other wise would not be possible due to the DPDIS head design. The design of the head does not require as much timing advance as the turbo EEC-IV put out so because of the mismatch of the newer head with the older turbo computer (LA3) the following steps have to be taken.

1st since there is no mechanical adjustment of the base timing in the DIS setup as there is with the earlier distributor setup found in all turbo 2.3L cars (this means turning the distributor). I figured that by trimming metal ( $1/16 = 2\text{deg}$ ) from the leading edge PIP tabs of the rotor that trips the crank trigger sensor (keep in mind the rotor turns clockwise as you stand in front of the engine) the base timing could be retarded from 10deg advance to 4deg advance. This setting helps limit total timing advance and in turn helps control detonation at boost.

2nd the OCTANE switch feature of the 87-88 TC LA3 computer has to be set at regular fuel so to limit total timing advance and controlling detonation even further.

I have been able to run 20psi boost spikes and 15 to 18psi boost continuous boost with out detonation while using a IC in both my 85 SVO and Pinto SW 89-93 DPDIS equipped cars while using a Saab APC boost controller. G-Tech test runs have shown a gain of 20hp in other words from 210hp to 230hp. Special thanks to Joe Morgan and Marcello Canitano with out their help the above timing adjustment would not have been possible.

Tachometer problems (remember) the DIS system tach pulse to the tachometer is of 12 volts so if the tachometer has a high resistor in the tach circuit it will not work. The fix is to add a 1k Ohm resistor in parallel to the first resistor inside the tachometer tach signal circuit or solder in a wire so to bypass the resistor. Yet some cars like the Merkurs will have no problems with tach signal. Then there is the 87-88 TC this cars will need a diode installed in the tach power feed circuit at the fuse box to filter out the DIS signal so it will not cause problems with erroneous reading with the tachometer.

The use of a efficient front mounted IC and engine coolant temperature control (around 180°F) is of the utmost importance in this setup in order to achieve high boost levels.

# 1991 R (Ranger)

60 - Engine

4 CYL. 2.3L - GAS - OHC

Engine parts - internal - upper

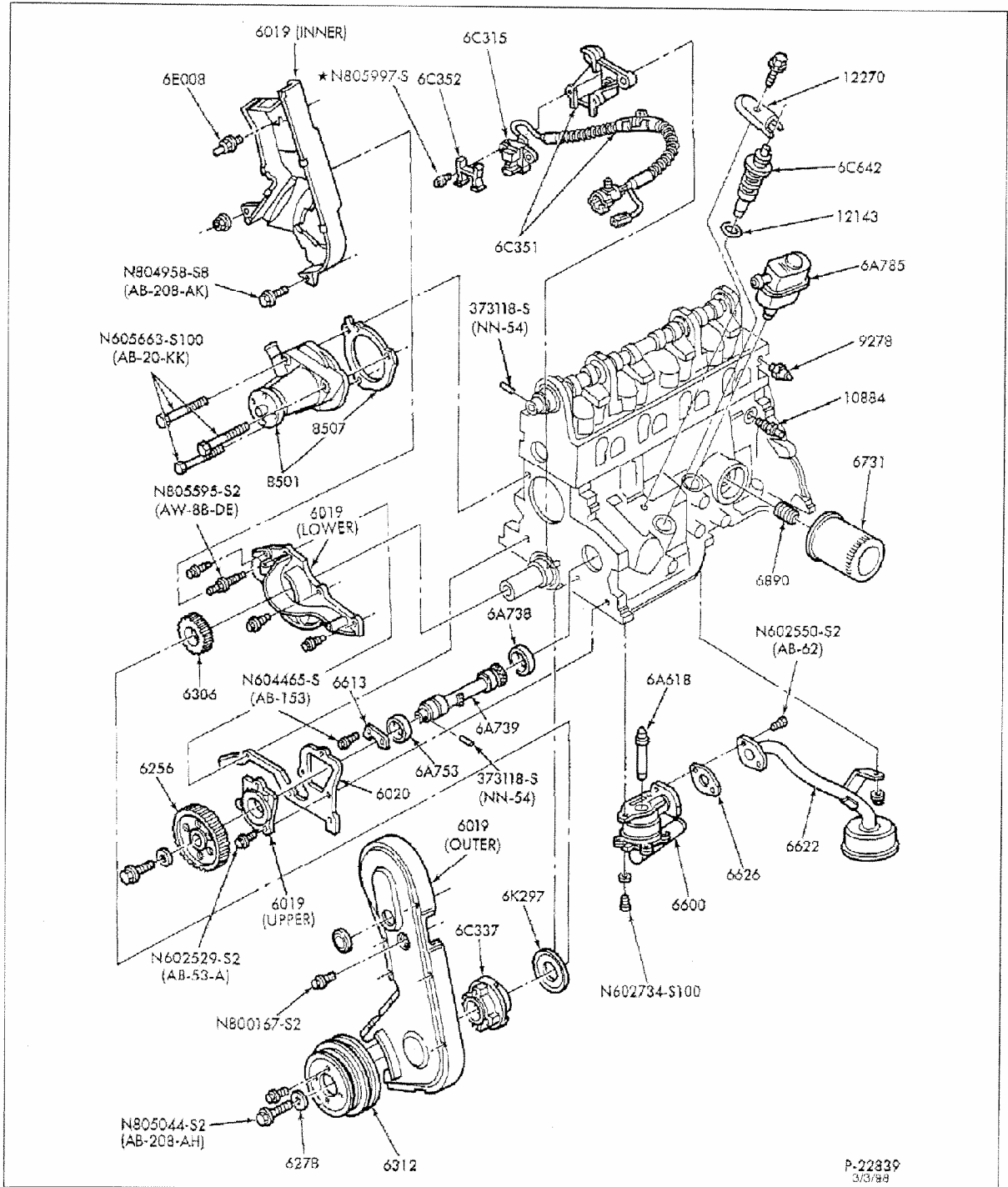

P-22839  
3/3/98

## EEC-IV Computer

---

- Code 34 EGR by Dave Compton and Charles Akins

**Q:** I have a 1986 XR4Ti w/134k and A/T. When I scan the EEC-IV I get a constant code 34 (EGR ON/OFF) The compression is ~140 across all 4 cylinders. TPS is set correctly. Idle and timing is within spec. EGO sensor is OK. Boost goes to 10 on gauge. Acceleration is Ok- seems a little mushy. Gas mileage is poor ~12 to 15MPG. I don't have a shop manual yet. How do I verify that the EGR is working/not working?

**A:** You are probably getting that code because of the delay valve that was inserted in line with the EGR valve during a recall. Temporarily remove the valve and test again. If you get code 11 then that's what it was. Reinstall the valve after testing. Check my TTT site Turbo Tek Toys

<http://www.TurboTekToys.com> TIPS for info on repairing it, if not. Poor gas mileage is probably leaky, bad, or dirty injectors or fuel filter. Possibly the O2 sensor. Dave Compton

**A:** In addition to what Dave C said.....there is a relay controlled valve mounted on the driver's fender well by the firewall that operates the EGR. If this is not operating, you will get the code. Follow the vacuum hose from the EGR over to it. 12V operates it open. After the KOEO test runs, you should be able to exercise it by applying full throttle on and off. I've had two fail. Charles Akins

---

- Which computer makes more boost ? by Jeff Baker

**Q:** I had heard you can get more boost with the '86 SVO computer ?

**A:** The computer doesn't inherently limit the boost, except through the ignition maps The boost itself will be limited by controlling the amount of boost the wastegate actuator on the turbo sees - when it sees 10psi, it will open and hold the boost there. The later turbo computers varied what the wastegate actuator saw through use of the BCS (Boost Control Solenoid), but that is one of the first upgrades most people make, to bypass the BCS and control the boost instead with a controlled bleed valve of some sort.

---

- What to the trouble codes mean ? by Jeff Baker

### EEC-IV Diagnostic Codes

- 11 - System pass
- 12 - RPM unable to reach upper test limit
- 13 - RPM unable to reach lower test limit
- 14 - Pip circuit failure
- 15 - PCM read only memory test failed
- 15 - PCM keep alive memory test failed
- 16 - IDM signal not received
- 18 - SPOUT circuit open or spark angle word failure
- 18 - IDM circuit failure or SPOUT circuit grounded
- 21 - ECT out of self-test range
- 22 - BP sensor out of self-test range
- 22 - BP sensor or MAP out of range
- 23 - TP sensor out of self-test range
- 24 - ACT sensor out of self-test range
- 25 - Knock not sensed during dynamic test
- 26 - VAF/MAF out of self-test range
- 26 - TOT out of self-test range
- 26 - TOT sensor out of self-test range (E4OD)
- 28 - Loss of IDM, right side
- 29 - Insufficient input from vehicle speed sensor
- 31 - PFE, EVP or EVR circuit below minimum voltage
- 32 - EVP voltage below closed limit
- 33 - EGR valve opening not detected
- 34 - EVP voltage above closed limit

- 35 - PFE or EVP circuit above closed limit
- 41 - HEGO sensor circuit indicates system lean
- 41 - No HEGO switching detected
- 42 - HEGO sensor circuit indicates system rich
- 44 - Thermactor air system inoperative-right side
- 45 - Thermactor air upstream during self-test
- 45 - Coil 1, 2 or 3 failure
- 46 - Thermactor air not bypassed during self-test
- 47 - 4WD switch closed (E4OD)
- 48 - Loss of IDM, left side
- 49 - 1-2 shift error (E4OD)
- 51 - ECT/ACT reads -40°F or circuit open
- 52 - Power steering pressure switch circuit open
- 52 - Power steering pressure switch always open or closed
- 53 - TP circuit above maximum voltage
- 54 - ACT sensor circuit open
- 56 - VAF or MAF circuit above maximum voltage
- 56 - TOT reads -40°F or circuit open (E4OD)
- 59 - 2-3 shift error (E4OD)
- 61 - ECT reads 254°F or circuit grounded
- 63 - TP circuit below minimum voltage
- 64 - ACT sensor grounded or input reads 254°F
- 65 - Overdrive cancel switch open, no change seen (E4OD)
- 66 - MAF sensor input below minimum voltage
- 66 - TOT grounded or reads 290°F (E4OD)
- 67 - Neutral/drive switch open or A/C on
- 67 - Clutch switch circuit failure
- 67 - MLP sensor out of range or A/C on (E4OD)
- 69 - 3-4 shift error
- 72 - Insufficient MAF/MAP change during dynamic test
- 73 - Insufficient TP change during dynamic test
- 74 - Brake on/off switch failure or not actuated
- 77 - Operator error
- 79 - A/C on during self-test
- 79 - A/C or defrost on during self-test
- 81 - Air management 2 circuit failure
- 82 - Air management 1 circuit failure
- 84 - EGR vacuum solenoid circuit failure
- 85 - Canister purge solenoid circuit failure
- 86 - Shift solenoid circuit failure
- 87 - Fuel pump primary circuit failure
- 88 - Loss of dual plug input control
- 89 - Converter clutch solenoid circuit failure
- 91 - Shift solenoid 1 circuit failure (E4OD)
- 92 - Shift solenoid 2 circuit failure (E4OD)
- 93 - Coast clutch solenoid circuit failure (E4OD)
- 94 - Converter clutch solenoid circuit failure (E4OD)
- 95 - Fuel pump secondary circuit failure - PCM to ground
- 96 - Fuel pump secondary circuit failure - battery to PCM
- 97 - Overdrive cancel indicator light - circuit failure (E4OD)
- 98 - Electronic pressure control driver open in PCM (E4OD)
- 98 - Hard fault present
- 99 - Electronic pressure control circuit failure (E4OD)
- 111 - System pass
- 112 - ACT sensor circuit grounded or reads 254°F
- 113 - ACT sensor circuit open or reads -40°F

- 114 - ACT outside test limits during KOEO or KOER tests
- 116 - ECT outside test limits during KOEO or KOER tests
- 117 - ECT sensor circuit grounded
- 117 - ECT sensor circuit below minimum voltage or reads 254°F
- 118 - ECT sensor circuit open
- 118 - ECT sensor circuit below maximum voltage or reads -40°F
- 121 - Closed throttle voltage higher or lower than expected
- 122 - TP sensor circuit below minimum voltage
- 123 - TP sensor circuit below maximum voltage
- 126 - BP or MAP sensor higher or lower than expected
- 128 - MAP vacuum circuit failure
- 129 - Insufficient MAF or MAP change during dynamic responded test
- 144 - No HEGO switching detected
- 167 - Insufficient TP change during dynamic response test
- 171 - Fuel system at adaptive limit, HEGO unable to switch
- 172 - HEGO shows system always lean
- 173 - HEGO shows system always rich
- 174 - HEGO switching time is slow
- 179 - Fuel at lean adaptive limit at part throttle; system rich
- 181 - Fuel at rich adaptive limit at part throttle; system lean
- 182 - Fuel at lean adaptive limit at idle; system rich
- 183 - Fuel at rich adaptive limit at idle; system lean
- 211 - PIP circuit fault
- 212 - Loss of IDM input to PCM or SPOUT circuit grounded
- 213 - Spout circuit open
- 224 - Erratic IDM input to processor
- 225 - Knocked not sensed during dynamic response test
- 311 - Thermactor air system inoperative
- 312 - Thermactor air upstream during self-test
- 313 - Thermactor air not bypassed during self-test
- 327 - EVP or DPFE circuit below minimum voltage
- 328 - EGR closed voltage higher than expected
- 332 - Insufficient EGR flow detected
- 334 - EGR closed voltage higher than expected
- 337 - EVP or DPFE circuit above maximum voltage
- 411 - Cannot control rpm during KOER low rpm check
- 412 - Cannot control rpm during KOER high rpm check
- 452 - Insufficient input from vehicle speed sensor
- 511 - EEC processor ROM test failed
- 512 - EEC processor Keep Alive Memory test failed
- 513 - Failure in EEC processor internal voltage
- 519 - Power steering pressure switch circuit open
- 521 - Power steering pressure switch did not change state
- 525 - Vehicle in gear or A/C on during self-test
- 536 - Brake on/off circuit failure, switch not actuated during KOER test
- 538 - Insufficient RPM change during KOER dynamic response test
- 538 - Operator error
- 542 - Fuel pump secondary circuit failure: PCM to ground
- 543 - Fuel pump secondary circuit failure: Battery to PCM
- 552 - Air management 1 circuit failure
- 553 - Air management 2 circuit failure
- 556 - Fuel pump primary circuit failure
- 558 - EGR vacuum regulator circuit failure
- 565 - Canister purge circuit failure
- 569 - Canister purge 2 circuit failure
- 617 - 1-2 shift error (E4OD)

- 618 - 2-3 shift error (E4OD)
- 619 - 3-4 shift error (E4OD)
- 621 - Shift solenoid 1 circuit failure
- 622 - Shift solenoid 2 circuit failure
- 624 - EPC solenoid or driver circuit failure
- 625 - EPC driver open in PCM
- 626 - Coast clutch solenoid circuit failure (E4OD)
- 627 - Converter clutch solenoid circuit failure (E4OD)
- 628 - Converter clutch error (E4OD)
- 629 - Converter clutch control circuit failure
- 631 - Overdrive cancel indicator light circuit failure
- 632 - Overdrive cancel switch not changing states (E4OD)
- 633 - 4WD switch is closed
- 634 - MLP sensor voltage out of self-test range, A/C on
- 636 - TOT sensor voltage out of self-test range
- 637 - TOT sensor circuit above maximum voltage
- 638 - TOT sensor circuit below minimum voltage
- 654 - MLP sensor not in park position
- 998 - Hard fault present

Definitions:

- ACT = Air Charge Temperature Sensor
- BP = See MAP
- EEC = Electronic Engine Control System
- ECT = Engine Coolant Temperature Sensor
- EGR = Exhaust Gas Recirculation Valve
- EVP = EGR Valve Position Sensor
- HEGO = Heated Exhaust Gas Oxygen Sensor
- KOEO = Key On Engine Off
- KOER = Key On Engine Running
- MAF = Mass Air Flow Sensor
- MAP = Manifold Absolute Pressure Sensor
- MLP = Manual Lever Position
- PCM = Powertrain Control Module
- SPOUT = Distributor Jumper to Allow Initial Timing
- TP = Throttle Position Sensor

Comments

1. Not all codes apply to all vehicles
2. Some codes have 2 listings, use the appropriate one

This info was found at Chilton's "FORD Full Size Trucks 1987-96 Repair Manual"

---

Here's another chart we found with some slight differences...

---

EEC-IV Diagnostic Codes, Rev. 1.1 2/25/93

11 (orc): No problems found in this portion of the test

12 (r): ECA could not increase idle speed above normal idle.  
Suspect throttle body coking. KE1

13 (r): ECA could not lower idle speed.



Suspect Idle Bypass valve problems. KE15

14 (c): Intermittent PIP signal operation.  
Suspect PIP sensor or TFI module, or grounding or interference problems at the TFI module. Y1

15 (o): ECA ROM test failure- failure is internal to ECA.  
(c) ECA KAM (Keep Alive RAM Memory) failure. Q10

18 (r\*): Loss of TACH signal from TFI (Thick Film Integration- the module on the side of the distributor) module to the ECA. There is an open in the SPOUT circuit.  
Suspect SPOUT connector. N1

19 (o): Failure of ECA voltage regulator. Replace ECA.

21 (or): ECT (Engine Coolant Temp) out of range. Coolant is less than 50degF for KOEO, or less than 180degF for KOER, or greater than 250degF for either. If coolant temp is in proper range, suspect ECT sensor (It won't be, for KOER tests on cars tha have a 160degF thermostat!) DE1, DE90

22 (orc\*): MAP (Manifold Absolute Pressure, for speed-density cars) or BP (Barometric Pressure, for mass-air cars) sensor signal out of range.  
Suspect MAP or BP sensor and harness. DF1, DF90

23 (or): Closed throttle TP (Throttle Position) sensor voltage out of range.  
Suspect TP sensor. DH1

24 (or): ACT (Air Charge Temperature) sensor voltage out of range.  
Suspect ACT sensor and harness. 1984-85 2.3 Turbo - Vane Air Flow voltage out of range. DA1

25 (r): 2.3 Turbo. Knock Sensor failure. DG1

26 (or): VAF (Vane Air Flow, 2.3L Turbo) or MAF (Mass Air Flow) signal out of range. Suspect sensor and harness. DK1

28 (or): 1986+ 2.3 Turbo. Vane Air Temperature out of range.

34 (r): 2.3 Turbo. EGR On/Off not working. KA1

41 (c): 2.3 Turbo. EGO read lean for more than 15 seconds while in closed loop. HA11

42 (c): 2.3 Turbo. EGO read rich for more than 15 seconds while in closed loop. HA8

51 (orc\*): ECT voltage too high (coolant too cold, circa -40degF!).  
Suspect ECT, harness. DE10, DE91

53 (orc\*): TP sensor voltage too high (indicates WOT condition). DH3, DH90

54 (orc\*): ACT (air Charge Temperature) sensor voltage too high. DA10, DA90

56 (orc\*): MAF (VAF for 2.3 Turbo) sensor voltage too high. DK10, DK90

61 (orc\*): ECT voltage too low- indicates coolant temp greater than 250degF. DE20, DE94

63 (orc\*): TP sensor voltage too low. DH10, DH94

64 (orc\*): ACT (1984-84 2.3 Turbo, VAT) sensor voltage too low, indicates intake air temp greater than 250degF. DA20, DA93

66 (rc\*): MAF (2.3 Turbo, VAF) below minimum test voltage. DK20, DK93

67 (o): Clutch switch open, AC left on, transmission in gear. FA1

68 (oc): 1986+ 2.3 Turbo. VAT out of range.

73 (r): Insufficient goose during Dynamic Response test. Rerun test, goose it harder. 2.3 Turbo - Faulty Throttle Position sensor. DH20

74 No Brake Switch Actuation / Cruise Control Switch Actuation Detected

76 (r): 2.3L Turbo only. Insufficient VAF variation seen during Dynamic Response test. DK30

77 (r): No goose detected during Dynamic Respose test. Rerun test, goose it harder. M1 81 (o): 2.3 Turbo. Boost control circuit failure. KN1

82 (o): 2.3 Turbo. Check EDF signal to Integrated Controller for short to ground.

83 (o): 2.3L Turbo only. Check for EDF signal to Integrated Controller for open circuit.

84 (o): EVR solenoid circuit failure. 2.3 Turbo - Check for EGR solenoid open circuit.

85 (o): 2.3 Turbo with Automatic (T-Bird). Check for 3-4 shift solenoid open circuit.

87 (oc): FP relay circuit failure- suspect inertia switch, fusible link, FP relay. J1

98 (r): Hard fault present. The ECA is running in FMEM (Failure Effects Management Mode), so something is royally screwed up that the KOEO test should have told you about. Rerun KOEO and fix whatever you find there.

99: ECA hasn't learned yet

## Electrical

---

- Crazy warning lights by Kevin, Mike, and Richard C.

**A:** That's usually caused by bad solder joints in the control boxes for the lamp monitoring and sensor monitoring boxes. They sit up on top of the EEC behind the glove box. If I remember correctly, these are made by Lucas (the company that invented darkness, the prince of darkness, etc etc). I "reheated" the solder joints on the boxes in my first XR, and it cleared up the trouble. Mike.

**A2:** 1) The unit is one of 2 metal boxes on top (not under) the EEC. One has a black and one has a brown connector. The warning lamp indicator is the brown one.

2) If you're not too crazy about soldering, just make sure you hit the big power transistors. (The ones with heatsinks on them) Basically the reason the "disco lights" happen is because a joint on one of those transistors goes, so the unit loses power. Then it comes back, thinking the car was just turned ON again. I would get all the joints if possible, but the ones with heatsinks are the important ones.

**A3:** here's another tip: just remove the panel (1 screw), remove all the bulbs, reinstall panel.

Another tip: if you resolder the computer that controls these lights (as Mike correctly points out), be sure to use a low-wattage soldering iron. Personally, I like Tip One better.

---

- Lazy Tach repair by Jonathan Compton and Dan Rhodes

**A1:** After enduring the three painful hours it took for me to re-install the hatch open indicator switch, my automotive repair confidence factor was at an all-time low. I knew, however, that if I were to continue my ownership of the XR4Ti, I would either need to become instantly wealthy or regain my earlier status (which was only slightly above the "barely competent" level). Having acquired some PCB soldering experience in the past year, the non-functioning tach would be the next victim on my "annoying issues with the Merkur" list.

I used Dave Compton's incredibly helpful tach removal guide from his turbotektoys.com site. The top steering column cover had one screw, the bottom had two. While there, I noticed that my hazard blinking light button cover was actually badly damaged at its base. (Little red cover added to list of junkyard parts wanted.) While in there, I took a peek at the turn signal wand...it will signal a right-turn, but will not turn it off on its own. It will usually not signal a left-turn unless I hold it down. I decided I would save this for another day since it was incredibly easy to get to it.

The cluster came out without a problem...I had to drop the part of the dash under the steering column to get to the speedo cable. The turbo gauge hose was chemically bonded to the gauge. The dash light dimmer & intermittent wiper dial were awkward, but not a real problem (I don't think Dave mentioned these...but, for a reasonably competent person, these would be a non-issue...). With the cluster out, I retreated to the air conditioned comforts of the kitchen table...(my wife was out of the house at the moment)...

With my trusty Phillips screwdriver, I had the tach & turbo gauge isolated...(which reminds me of another example of my cluelessness...I had put "posidrive driver" on my list of tools to acquire after finding many references to it on several different websites. I had never heard of one of those and hoped it wasn't too expensive. I didn't realize I had dozens of them already...since it's just a generic name for a Phillips...)

I thought the needles would pull right off, but they seemed very reluctant. I didn't want to do any damage, so I tried to find a way to the little circuit board without removing them. No possible way...a quick prayer and a little more effort and they came right off.

I looked over the board and finally found a loose solder point...on the red wire, which is a good thing since it wasn't on any of the more-sensitive components. I fired up the trusty Radio Shack soldering iron (15/30 watt) and "pop"...it was dead...turns out, I fried up the iron. (A 10-minute detour to look into the iron and I found I had burned through one of the heating wires. I must have twisted a short into it when I tightened the tip.) This meant the only option I had in the house was an old soldering gun. It didn't have the wattage on it, but it was at least a 40 watt...this sucker dimmed the lights in the house...way too high for PCB work...but I didn't want to take a trip to get a new iron, so I had a beer...and thought...and pondered...and rationalized...it was just a

jumper wire...so I finished my beer and squeezed the trigger. A few short seconds later (okay, several seconds...this thing was seldom-used for a reason), the solder turned to liquid and the connection was solid again. No melting, no crossing any connections, it was perfect (enough)...and you thought this was heading for disaster, right?

I put the needles back on, the gauges back together, the contact nuts back on...(while putting on one of the contact nuts, I noticed it was starting to pull the copper up from the board...be careful when putting these back on...) I didn't have any extra vacuum hose lying around, and was too lazy to go buy some...so I trimmed an inch off the end of the existing hose and put it back on. The whole mess was back in the dash and the dash reassembled in a surprisingly short time...and not a single extra part left over. I turned the key on the 2.3 half-expecting either absolutely nothing or needing to use my newly-acquired fire extinguisher. The needle jumped to 1k and I let out a primal victory scream that immediately brought the kids to the garage to see what body part Dad had lacerated/burned/smashed this time...(me screaming in the garage and bodily harm were usually closely correlated...the kids are eerily fascinated by this). I revved the engine a few times and the needle followed.

**Q2:** My tach has gone lazy on me. Has anyone resoldered their cold solder connections and, if so, would you please share with us (especially me) how to do that? I know how to get the gauge cluster out (lord knows, I've done that enough) and I've got a solder gun. TIA.

**A2:** I hope that the term "solder gun" is used as a generic name and you really don't plan to use a solder gun on your tach. Solder guns are far, far too hot for a printed circuit board and you will quickly delaminate the copper circuit pads and traces destroying the board in the process. A solder gun is a 150 watt device and is OK for BIG stuff.

Ideally, a 22.5 watt soldering iron should be used for printed circuit work but you can get away with as much as a 47 watt iron if you are careful. You also need some 24 ga rosin cored 60/40 solder (good 22 ga solder is OK, but you have to be careful and not get too much solder on the joint or you run the risk of "bridging" to adjacent traces or pads). Radio Shack is a marginal supplier for this kind of stuff, you would be better off going to a good electronics supply store (sorry about that, Radio Shack - I do use them for some things).

Resoldering all the joints on your Tach board should not be too difficult a job, just be sure to reheat the joints until the solder reflows and just touch the solder to the reheated joint. Remember that the key to a good solder joint is first of all, a good mechanical connection, and the solder is applied to the joint and NOT the soldering iron (except to "tin" it). Keep the soldering iron clean, clean it between resoldering joints, the tip should be "bright silver" in color with no rosin flux residue. A wetted paper towel is good for this, wet one and fold it into a small rectangle. Squeeze most of the water out of the towel and wipe the iron on it between resoldering joints. If you happen to wear Levi's (which I usually do) you can also wipe the iron tip on your pants leg, that also works well.

Don't miss resoldering any joints, start "left to right, top to bottom" or some such system. The Merkur (both XR4Ti and Scorpio) is full of bad solder joints, the manufacturing plant for the electronics should have had everyone take and pass a military specification soldering class before being hired for assembly work!! Good luck!! Be careful, the circuit boards are sensitive but this process very often gets good results. I have resoldered the fuel gauge, temp gauge, tach and speedometer boards in my Scorpio and this has helped the functionality of these instruments.

- 
- Fix for Scorpio dead Tachometer and Cruise Control by Conrad  
This has to do with a Scorpio. I just fixed my dead tachometer and cruise control by simply replacing one little part. The part is some type of filter I think which is located near the coil. May be all wrapped with tape so not readily visible. The green tach wire comes off the coil and goes into and out of this filter before going on to the tach. After spending two years driving with no tach or cruise control, I finally solved the problem. Discovered there was no electric signal at the post on the back of the tach. Started tracing the wire back to the coil and found the filter. I found no continuity through the filter, so put one on from another car and what do you know? Both tach and cruise control now work.

There are two green wires coming off one side of the coil. One goes to the tachometer, the other goes to the speed control module under the dash. So they are connected in some way. I suppose a broken or shorted wire could cause the same problem I had. If your tach and cruise control don't work, first test the little filter to see if there is continuity. There seems to be a few ohms of resistance. Don't know what the limit is supposed to be, but mine had zero continuity.

I have tried everybody else's suggestions and nothing worked. Hope this one works for someone else out there.

- 
- Battery light comes on at start-up by Lih-Yen

This is a known problem with the earlier XRs. There is actually a Ford TSB addressing it which adds a power resistor to the back of the instrument cluster. They fixed it from the factory about '88.

TSB Article 87-6-3

Electrical Systems - Alternator - Regulator - Starter

"Charging System Inop. After Cold Start"

Alternator warning light stays on after cold start due to not enough voltage passing thru warning lamp to alternator. This is serviced by installing a 100 Ohm/10 w resistor in parallel with warning lamp. Resistors may be obtained from electronic outlets such as Radio Shack. This problem affects all 1985 - 1987 Merkur XR4ti models.

- 
- Scorpio Alternator Light question by Jerry Chandler

**Q:** It is very cold here in Northern Virginia. It was 6°F and the wind was blowing very hard making it even colder. The Scorpio started very slowly. I got about 6 miles when the battery gave up the ghost. I was driving on the battery and it was depleted.

The charge light never came on. I checked the bulb condition and it's good. When I turn the key, it never comes on. Bad alternator?

**Dejan Cokic:** Test the alternator with a voltmeter while running to see how much it puts out.

**Q:** But what does the 'no light' condition mean?

**A:** The charge/alternator dash light is an integral part of the charging circuit. If it does not light, the alternator will not charge, even though it is functioning. The bulb should illuminate when with the other dashpod lights when you start the car. This is the startup test mode.

Install a new bulb or get the existing one (the one that 'tested' good) to work. If that bulb does not light up, you will never get the alternator to charge the battery.. just won't happen. Ask me how I know. Oh,.. don't fool with anything else until you get that bulb to light up.. you will just be wasting your time. once again.. ask me how I know.

- 
- Rear Hatch Open Indicator Switch Replacement by Lih-Yen  
(see Body-Electrical section)

- 
- Intermittent Tachometer Fix by Ed McCaslin

I was experiencing similar symptoms with the tachometer in my '87.5. Two weekends ago I found a fixed the problem, so I'll share my discovery with you in case it's a common occurrence. On the tachometer, on the small circuit board, the red wire runs through one of the holes and is soldered with a stud termination on the back side. The red wire solder termination on mine was pushed up off of the board, and was making intermittent contact.

To remove the tach, I separated the cluster by removing the five screws around the outside. Then, right behind the tach, remove the three nuts from the cluster back (one of them has a black wire lead). With the nuts off, the tach is free from the cluster. I pulled-off the boost gage and tach needles. then removed the two corner screws separating the tach from it's dial. Next the boost gage comes away from the circuit board by removing the nut. Then use a small screwdriver to release the circuit board from it's clips, and the wire terminations will be visible when you turn the board over.

- XR4 with clacking relays by Bill Stobbe  
All, Great thanks to Don for posting about clacking relays and the computer being the problem. My '89 died in March (it's my winter car) so I had to put my summer car into service early.

Symptoms:  
Clacking relays  
battery drains quick

Fix:  
Re-attached black ground wire, which goes to battery box, changed computer

Commentary:  
Black wire relieved clacking relay symptom.

QUESTION: what is that black wire for anyway? EEC ground?

Computer changed 1st hoping it would fix problem. After taking out new one, since I was sure ground wire was problem, found I needed computer too.

This is a great list!

- Alexander Chaney adds:  
The car that Don was referring to in his original post was my Merkur.

We were working on several issues with the car one night and when we were all done, we turned it on and the relays clicked liked crazy. When we tried to turn it over, it just refused to start.

Don immediately tried to run the codes, but no response, which led us to believe that it was in fact the computer. Don had a couple LA and PK boxes around, so we tried the PK and the clicking stopped and the codes came through. And of course the darn thing started.

- Wiring a 3G (Ford third generation) alternator into an XR by Unknown  
No problem. On a 3G into a Merkur, the one single (blue) wire from the Merkur's harness goes to the green and red wire (probably labeled as "I" on the alternator case) on the alternator's 3 wire plug. The yellow and white wire (probably labeled as "A" on the alternator case) on the plug goes to where the main battery charging lead goes (the stud for the ring connector) of alt. The middle black and white wire (probably labeled as "S" on the alternator case) goes to the stator connection on the alt. and your done. Because my G3 was uprated and puts out over 170 amps., I ran a 4 gauge power wire to the starter solenoid. I had previously used the t-bird alt. but found out that it was only 75 amps. The factory Bosch Merkur is a 90 amp. and a stock Ford 3g is 130 amps.

- Testing the Charging System by Mike  
I see posts like this that make me cringe. Pulling the battery to test an alternator does not work. Years ago when cars had generators this test would work because generators put out DC (Direct Current). Then someone developed alternators which put out three phase AC (Alternating Current). The output of the alternator is rectified by six diodes into DC. The problem is to produce the AC it requires an excited field which is produced by 12 volts energizing a stator winding. This 12 volts is supplied by, (you guessed it), a battery. Removing the battery causes the whole thing to shut down and the car dies. Ever wonder what the little wire is going to the back of the alternator? That is the one going to the stator winding. Pulling it won't shut the car down because the battery is still running the car until it has exhausted its charge but it will stop the charging system from working. So everyone stop pulling batteries and pull the alternator. Take it to a competent repair shop to test it and the built-in regulator.

**Ian adds:** Most alternators, once energized and spinning, will continue to build voltage even when the battery is disconnected. They will continue until they eventually destroy themselves due



to there not being any control voltage signal (12v battery) to limit itself. NEVER disconnect the battery when the vehicle is running or you will be buying a new alternator.

---

- Scorpio Speedometer Cable by Jake Delgado

After 103,000 miles, my 88 Scorpio's speedometer died on me...

**Q1:** Is it most likely a cable break or could it be something else to cause it to go out? If a cable break, advice would be appreciated for the best strategy on replacing it. Not surprisingly, the CRUISE CONTROL also went out, since the computer is linked directly to the speedometer...

**Q2:** How can the computer still give me a readout on my mileage RANGE? (Range read-out drops down as usual as I drive).

**A:** There is no speedometer cable in the Scorpio to speak of. There is a speed sensor in the transmission tail shaft housing that provides speed information to the speedometer, speed control and computer. The speed sensor fails fairly commonly and is most likely the cause of your problem. The trip computer will keep trying to guess MPG and so forth even though it thinks you are running the engine a lot and not moving. Here is a message from Tom on the list from about a year ago when he had to replace the sensor:

Just bought one from AutoZone for \$63.00. Its a Wells SU1031 but the part appears identical to the OEM item and even has the Ford logo. Took 8 days to order but it came and it works.

I have also heard you can get them from NAPA, but I have not tried them myself.

---

- Resistor in-place for charging on later clusters by V.Callaway

Later instrument Clusters have a 120  $\Omega$  0.5 watt resistor soldered across terminals on the circuit to permit the charging system to function if the cluster bulb blows.

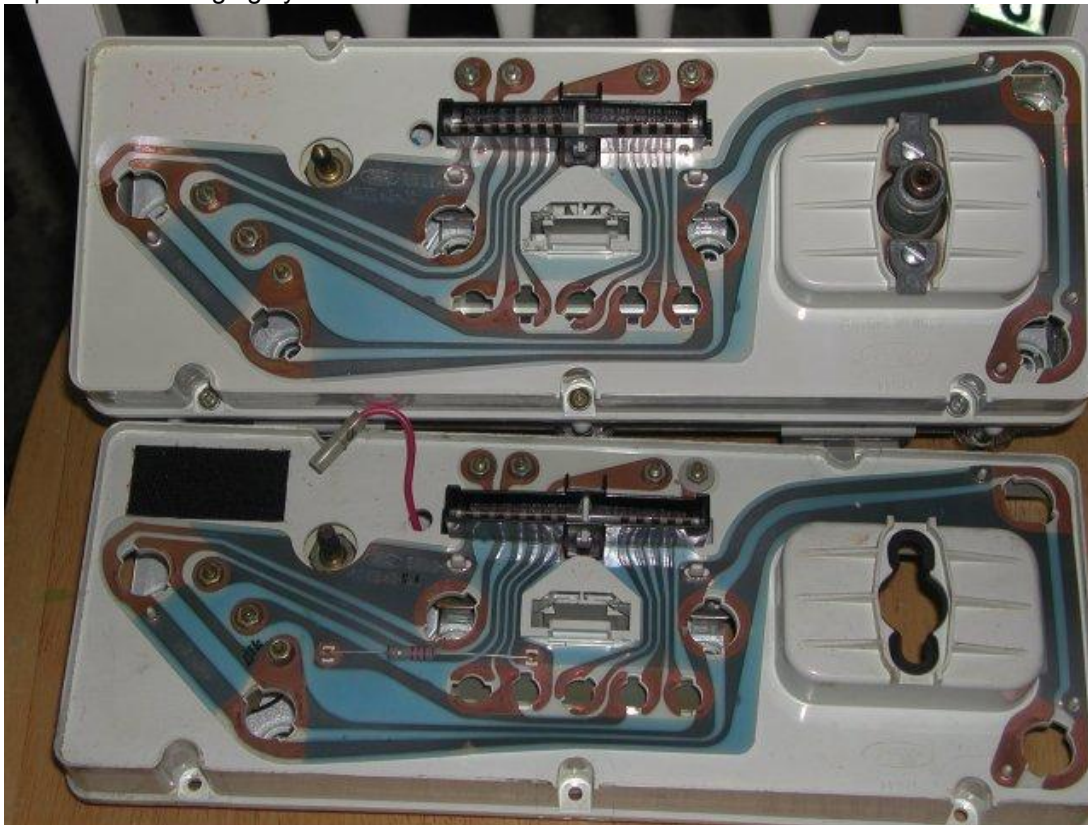



## Engine

---

- Ranger valve cover gasket info by Ian Glyn-Jones of the XR Connection

THE best valve cover gasket available is the Ford gasket for the Ranger. This is much better designed than the Felpro one. Felpro used to make them for Ford but there was a high level of failure so they dropped it. My car almost burnt up due to this gasket splitting on the turbo side and spraying oil onto the turbo. Also, the Felpro gasket is not reusable whereas the new Ford one can be over and over. It has a reinforced rail along the entire length except where it goes over the cam tower at the front. Part # is F57Z-6584-A  
Get it and you will never have to worry about it again.

Also...I'd go to your friendly FML dealer. I have a felpro one that is just plain rubber but it does not have the rigidity that helps when you install it.

---

- Ranger Improved head bolts from Ford Dealer by Stan in Pugetopia

Ranger Head Bolt Kit (10 Bolts with instructions)

Old# - F3ZZ-6065-FA in 2000 \$19.99

New# - F3ZZ-6065-FB in 2002 \$38.53

---

- Steam Holes in Engine Block info by Rick Byrnes and Brad Anesi

Edward Key asks: I remember sometime in the past, someone (maybe Allan Slocum) was going to try to drill some additional passages in their cylinder head to help eliminate steam pockets. Rick Byrnes did this on his turbo race engine.

Brad Anesi responds: A few of us have done this - Randy, Rick, Allan, and myself - we all stole the idea from Roush, although credit Rick for documenting the concept. It's hard to say whether it really matters in the real world, but there doesn't seem to be a down-side, so I didn't hesitate. Check the Files section under "Brad's stuff" if you want to see where the holes get drilled.

Rick Byrnes Wrote: Well, I am finally getting around to writing again. Actually, we did not steal from Roush. What Lee White was doing in the GTO program was cross flow cooling in the head and communication from block to head on the intake side. I could not utilize this system, so copied SB chebby siamese bore cooling holes. The intent was for my siamese bore SVO block, but I think the additional water movement helps all blocks. I also used a water port near each exhaust port to exit steam and water as necessary. This may have helped more than the transfer holes. Without back to back tests under exactly the same conditions it's hard to tell. We need to remember my water pump flows considerably more than the 2.3 paddle wheel.

---

- I have the part number from the Merkur encyclopedia for the Felpro F57Z-6584-A . .

Three questions:

- 1.) Is it possible my gasket is reusable? I can see that it is the blue rubbery one . .
- 2.) Is the Felpro gasket a dealer item only? (the encyclopedia says \$25)
- 3.) I'm swapping in the 'all black' valve cover from my parts car because it looks better . . Is it desirable for any other reason(s)?

Thanks,

Craig "cramadmerk"

---

- Some have used the Felpro gasket with no troubles, but I would recommend the newest FORD creation for a 93 Ranger instead. I just went through this process and this gasket is very nice and re-usable. It was about \$30 from my local dealer. I believe there was a Ford engineer on this list not long ago talking about why this gasket works so well. Make sure you don't have any leftover load limiters on the the bottom of the valve cover you're replacing. When the valve cover bolts are overtightened, the metal in the gasket impales itself into the bottom of your valve cover. The valve cover surface should be nice and smooth. Scott McClure 89 XR 5spd with a limp ps. Sorry, I can't find the part number, anyone else have this # ?

- 
- They both were the last I got them less than a year ago. You will have to get the belt from a Motorsport dealer. Not all Ford dealerships can get the Motorsport parts. The belt tensioner can though.  
Belt Part # M-6268-A221  
Tensioner # F57Z-6K254-A

Good luck.

Ian Glyn-Jones  
The XR Connection  
Ontario, Canada

---

- Service bulletin on correct flywheel bolt torque by Don  
I was at the Recon engine remanufacturer site. They have a tech tips section. It lists the 2.3 and states that the rear main seal will leak if you over torque the flywheel bolts. They list 65 Ft.Lbs. as the correct torque. Click on Tech Tips. FYI <http://www.reconengines.com/index2.html>
- 

- Sources for replacement motor mounts by Brad Anesi and Ed McCaslin

**From Brad Anesi:**

You want the mounts from the V6 T-Bird, not the TC.

There appear to be at least 4 similar mounts that are available.

They are: Ford E9SZ-6038-(A-D) Fluid Filled '89 3.8L T-Bird

..... Anchor 2661 Fluid Filled (75mm)

..... Sealed Power 270-2864 Solid Mount (cheapest price)

..... Sealed Power 270-2865 Fluid Filled

**Ed McCaslin adds :** I just got two of the Anchor 2661 mounts from Wrenthead.com (\$55/ea ). I open the identically packaged Doan boxes, only to find that there must be (at least) two different suppliers. One mount measures 82mm in height, has the center hole pre-drilled (not tapped), but has no locator pin in the base. The other measures 79mm, has only the outer threaded 8mm holes drilled, but DOES have a locator pin on the base.

I'm going to work on getting a pair of the 82mm mounts since I want maximum height, the center hole is already drilled, and the upper metal surface appears to be thicker (it is at least 15mm thick). Since I'm going to use the upper 8mm holes to prevent any rotational movement (stock aluminum arms will be drilled), I'm not concerned about the loss of the lower locating pin.

**Rick Granlund adds:**

These are all the same mount. The numbers are just each mfg's number for the same part.

I did this -this past weekend. It was a simple project. The 2661 mounts have a lower stud-M12-1.75 and upper center hole I drilled and tapped to 3/8-16 and used a 3" bolt. One of the small outer holes on top of the mount (there are 2)-5/16 fine- I put a bolt in then cut off the head into a stud) and drilled the upper keeper plate and the motor engine bracket to size to keep them all lined up. I used the solids for my son's car, but now that I have done it, will use the liquid mounts for my '88.

**Preston Anderson adds:** The mount I used is indeed for a 3.8 T-bird. The same mount was used from the 80's well into the 90's thus spanning the Fox and MN-12 chassis. The exact part I used was a NAPA 602-1649 Hydraulic Motor Mount. It is rumored to be about 2mm taller than the stock Merkur part. No biggie in my book, just realign the driveshaft after install if necessary. Probably ought to check the trans mount and guibo anyway.

This mount is not a simple bolt in part, it requires modification to both the mount and your crossmember before it will work. The hardest part of the process is threading the central hole in the top of the mount. I used M10 X 1.5 stainless rod. I drilled out the central hole and threaded it for the rod. It was very hard to cut the threads in this material. It might save some frustration if you farm out this task to a machinist. I used stainless rod and cut it to the same length (installed) as the rod/stud in the stock mount. Permanently secure the rod/stud with Loctite red (282 or 287) or better.

The stud on the bottom of the new mount is M12 and you will need to drill out both the lower portion of the bracket that goes around the mount and the crossmember. The stock hole is for a M10. Also, you will need a M12 nylock nut for the bottom too, it doesn't come with the mount.

You may or may not feel this is necessary but I also added locating pins in the upper and lower portions of the mount to keep from twisting the rubber mount when tightening the nuts on the mounting rods/studs. I used a 10/32 x 3/8" hex set screw on the bottom and a M8 to M6 reducing set screw into one of the two existing threaded holes in the top of the mount. You'll have to drill and thread the bottom of the mount to accept the locating pin. I found both of the set screws at Lowes.

Being as I was also changing a steering rack at the same time I removed the entire crossmember and assembled it with the new mounts then jacked up into place. It was also damn cold outside (26 deg F) when I was doing the work so I did as much work inside as possible. You likely can do the mount installation including drilling out holes in the crossmember from under the car by jacking the motor up a few inches. If you have the car on stands you can also loosen the crossmember (2 bolts each side) to gain a little more clearance.

But wait there's more.... **Only the hydraulic 3.8 mount has enough material to cut the necessary threads into. The solid rubber 3.8 mount will NOT work.**

The new mounts in my car have been in for just over 1 year with absolutely no issues.

- Incorrect XR dipstick mark and proper oil quantity by Don
- Q:** What harm(s) does too much engine oil do? Oil leaks? Blue smoke?  
**A:** Blown engine seals, low horsepower, parasitic drag, oil coming out of the dipstick. Use five quarts only with the stock filter. Then mark the dipstick after sitting for twenty minutes. The dipsticks are wrong from the factory and were the subject of a Technical Service Bulletin.

- Engine Part Numbers by Richard Thompson  
 Melling brand standard volume oil pump is Melling number M-86E  
 Standard Main Bearings: Clevite 77 brand MS-1117 P  
 Crankshaft, aux shaft and cam oil seal Ford E8ZZ-6700-A  
 Sealed Power Rings E-441K .50mm (0.020" oversized bore)

- List of Parts to build a Performance Cyl Head by Terry Watson  
 Here is the parts list I put together when I built up my head.

### 2.3 Head Parts List

Item	Qty	Size	Source	Part#	Price	Phone
Valves, Int.	(4)	1.890"	Mid-West Motorsport	SIV23I	\$40.00	913-334-0477
Valves, Exh.	(4)	1.590"	Mid-West Motorsport	SIV23E	40.00	913-334-0477
Springs, Retainers, Locks	(16)		Mid-West Motorsport	MWM935	40.00	913-334-0477
Springs	8		Mid-West Motorsport	CRA 998848	64.99	913-334-0477
Lifters	8		Mid-West Motorsport	FMPHT2012	35.00	913-334-0477
Head Stud Set	1	ARP ARP1514702		95.00	800-826-3045	
Adj. Timing Gear	1		Race Engineering	JM-1201	89.00	561-533-5500
Timing Belt	1		Race Engineering	JM 121HD	25.00	561-533-5500
Head Gasket	1	Felpro 1035		52.00		
Intake (Upper) Gasket Set	1		Felpro	MS 90266-1	6.00	
Rocker cover gasket	1		Ford	F57Z-6584-A	33.00	
Cam	1	NAPA 87.00		310-676-2228		
Cam Bearings	1 Set		Vellios	DUR-F-34	25.00	310-643-6613
Cam Seal	1		Ford	E8ZZ-6700-A	10.00	
Roller Rockers	8		Vellios	SPW-R-1006	136.00	310-643-6613
Exhaust to turbo gasket	1		Nissan	14415-V0301	15.00	

Total \$792.99

- Distributor Components Troubleshooting by Kenny Heck



Couple things I've seen mentioned on this thread that probably ought to be clarified. As the problem seems to be no-spark related, I focus on those issues. There are actually two electrical parts in/on the distributor that may fail. One is the Hall Effect Sensor (referred to as PIP by Ford: Profile Ignition Pickup sensor). This item is inside the distributor and requires disassembly of the distributor for replacement. Early ones (black in color) had a higher failure rate than later ones (yellow in color). Though the PIP tends to fail less often than the TFI (Thick Film Ignition) module on the outside of the distributor, I have on one occasion had to replace one. Failure of the TFI is much more common (note the dispute in courts with Ford over this exact issue). Failure of either of these will produce no spark at the coil and is definitely more likely than a coil failure (not seen a coil failure yet! though it is possible). BTW, for all the bad rap of the Ford TFI, I have seen WAY more failures of aftermarket TFI's than the Motorcraft variety. As either of these parts can produce a no-spark condition, it is not possible to say for sure which may have failed (if the rest of the system is functioning properly) without removing the TFI and testing the components individually. Another possibility that was suggested as highly unlikely is actually quite possible. The distributor is driven by the aux. shaft (which is driven by the cam belt) via a worm gear assembly on the aux. shaft. Though not likely for the aux. shaft itself to "break," it is very possible for the worm gear assembly to strip. I've owned 2.3 turbos since 1990 and have put in the vicinity of a couple hundred thousand miles on them without incident in this respect (including engines that were already high mileage) but have had this happen to me three times in the past year, twice in one engine and once in another. Easily diagnosed by pulling the distributor cap and watching for rotor movement (assuming your timing belt is good). Unfortunately, every time this has damaged both the aux. shaft and the distributor gear, requiring replacement of both of these parts along with removing the oil pan to remove the shrapnel (which did NOT come out with a simply oil drain). Not fun... As stated by others, if the timing belt is shot, obviously the rotor in the distributor won't turn either, so it really needs to be checked before assuming what I stated in the previous paragraph is a problem. Easily checked by simply watching the cam belt guide plate at the back of the cover while cranking the engine. There is a HIGHLY important consideration when checking either a broken timing belt or a "stripped" auxiliary shaft. The oil pump is driven by the distributor. If the distributor is not turning then you are getting NO oil lubrication to your engine. DO NOT crank endlessly trying to figure this out or you will likely cause more problems. Quickly determine that your distributor is indeed turning! And one last note: one member suggested are placement distributor from Autozone. A very worthwhile consideration if you find problems, but keep in mind that the distributor does contain electrical components (the PIP) and typically auto parts stores do not give refunds on installed electrical devices, even if you determine it was not the problem. You maybe able to get away with it a few times, but I wouldn't want anybody to get stuck by this either.

- 
- Plug wire choices by Dave Compton and Alan Coles

If you are buying Motorcraft wires make sure to buy the Merkur specific set. Unlike wires for a Turbo Coupe T-bird or Mustang SVO, the Merkur set has 100% silicone boot ends. I've never had a problem with them disintegrating don't sell them anymore and I don't know how much they cost. The part number is WR-4036. WR-4011C is spec'd for Turbo Coupes and SVOs, and have regular boot ends. Be aware that wires are a wear item and will need replacement about once a year. Dave Compton

- Alan Coles adds:

Tim and others, the archives are your best source for this type of advice. There are hundreds of threads on plug wires, with many good "Been There Done That" antidotes. The bottom line is that the stock plug wires are very difficult to beat unless you are running a highly modified (300+ hp) motor. Don't believe me, believe Rick Byrnes as he has stated in the archives. (Originally published in the Official Show Directory, 1997 Carlisle All-Ford Nationals - Four World Land Speed Records. The World Record for the one mile standing start. Over 500 horsepower and top speed in excess of 205 MPH. All from a modified, off-the-showroom-floor, production four-cylinder Merkur XR4Ti. That's what Rick Byrnes of Dearborn, Michigan has accomplished so far in pursuit of his favorite hobbies: FORDS and SPEED.) This was in 97. In 98 Rick set a fifth Land Speed Record with the XR4Ti. World Record Land Speed holder - 1998 - 204.952 Fastest speed



208.389. What most people don't remember is that Rick used to Drag Race the XR4Ti (for testing purposes). It ran an 11.53 second ET and with trap speed of 120.46 MPH. You'd better believe he knows what it takes to deliver good spark. Rick's advise and many others is - there is no need to spend your money on trying to re-invent the wheel. Nobody has produced a measurably better ignition for a stock to medium modified XR4Ti than the stock Ford parts. Sure, Magnecor, Rapido, etc., will make claims, they want to sell their wires! They look nice and work well (I've used them) and usually last longer than the Ford wires. But, why would you want them to? Buy the Ford wires, and replace them every 1-2 years when you replace your spark plugs. They have a lifetime warranty so there is no additional cost, the Motorcraft/Autolite plugs are very well suited to our motors, so just pick up the wires (under warranty) at the same time you pickup the plugs. The under hood temperatures of our cars are way too hot (although I did get 7 years out of a battery on one of my XR4Ti's and six years out of it's second battery). Spend the money, time and energy you'll save on venting the hot air out of the engine compartment. That wouldn't be re-inventing the wheel. It would be making a great vehicle even better. Just my opinion.

- Tim Wojtyniak

I bought a set of Magnecor 10mm wires over five years and 140,000 miles ago and they immediately smoothed the idle. The people at Magencor say that the XR is especially vulnerable to electromagnetic interference and thus recommend the their special EM suppression wires. They make and sell wires for a living, so I figure they know, and my experience has been excellent. Occasional boot sticking (I'm going to look into the mica thing), but the wires and boots are still pliable, clean up well and don't seem to be bothered by heat at all. I can't imagine putting anything else on it. Especially replacing them annually. If I recall correctly, Magnecore offered a IMON discount when I bought mine. BTW, I had a battery that lasted for five years and 120,000 miles in the stock location. The secret (I believe): get one that you can add water to when necessary. Many of the "maintenance-free" batteries have tops that can be removed to replace the water that boils out of them in the XR. I check mine about twice a year and add as necessary.

- Spark plug info by Brad Anesi

**Q:** It's time for the annual tune-up. What was that NGK spark plug that performed the best on the high boost test? Was it a NGK 5RU or something like that?

**A:** I just put a batch of these in, so the box was close at hand...NGK V-Power TR5 Stock No. 2238----

**A:** Richard Curtis suggests: **Autolite 764**. Cheap, change 'em often. Available at NAPA. Gap at 0.030. They're also available at Wal-Mart. \$1/each. I always carry an extra set.

- Mysterious Oil Leak from top of Engine info by John and Jason Richardson

John---Found of new source of a lot of oil leakage: valve cover oil-inlet cap. Took a long time to find it because the oil moves to the rear of the cover, runs down the passenger side of engine, onto the bell housing, tranny & sway bar. Makes it look like either the air breather is plugged, or valve cover gasket is shot, or worse, like a bad rear seal. And, I'd clean all the oil off, and it was right back the next day. Really had me worried. I was "relieved" to pay the relatively steep cost of a new one from Ford for \$20.20. Seems there's something of a run on the older style caps (i.e., not the true screw in kind w/ the later valve covers); these are not obsolete yet. Maybe check yours, or get a spare.

Jason Richardson adds : Ahh yes, I had forgotten about that since i went to the newer style [:]) It seems those older ones have a design flaw, in that the rubber gasket on them cant hold up to the heat and slowly melts away. I guess I hadn't thought of it cuz I figured it was common XR knowledge; when I got my car I was lucky enough to have other XR enthusiasts come along with me, and the first stop we made after purchasing the car was the nearest Napa to buy a new cap, as well as a new pcv valve.

**John---**Yep, the gasket melts & warps away just enough to leak oil, but not enough to allow you to try a gasket, or O-ring, etc.. For emergency, I guess you could use copper RTV.

---

- Exhaust Manifold Gasket by Ian Glyn-Jones

Take the FelPro exhaust manifold gasket and put it where it belongs...in the garbage. They will not last in our turbo applications. The only one that will (if you really need a gasket in there) is the newer Ford Ranger gasket F37Z-9448-A. You would be even better off if you had the manifold planed to true it up then no gasket would be required at all.

---

- Serpentine Belt Setup by Saul Lipton, Dimitri Wittal, and C. McKeel

**Q:** Does the AC compressor have to be changed as well as its mounting bracket. The bracket contains the tensioning bogie. The alternator and PS pump will have to go on a different bracket as well. This bracket contains the tensioner for the belt used here.

**A:** Actually, the AC compressor does NOT have to be changed to use serpentine belts. You can grab the pulley and clutch from an early 90's 2.3 mustang and swap it right on to an XR's stock compressor. Those stangs use the same Nippondenso unit (with a different mounting configuration).

**A:** Charles and Chris McKeel adds:

Dims is correct, but I can't remember if the tensioner can be used unless you switch to the Mustang style compressor and bracket as well. I put the serpentine belt on mine just to be able to switch to the Mustang compressor. However, I had to trim one of the mounting points from the compressor housing in order to accommodate the Merkur specific compressor service plate which gets mounted to the Mustang compressor. This allows the use of Merkur A/C hoses, but probably degrades your compressor core value upon the next return! The complete serpentine conversion is quite easy.

The mustang is the best donor. I used the mustang compressor, the Merkur alternator, and even the stang steering pump (the Merkur pump should be used, but I was too lazy to swap the pump pulleys). The mustang alternator bracket is used, and the Merkur alternator gets installed sort of upside down, since the stang set up use the alternator long mounting bolt at the pump position. I had to do some grinding of a bracket or two, and the mustang alternator bracket had to be shimmed to get proper fitment.

I also converted to a t-bird power steering pump w/ remote reservoir on another XR4, using V-belts. This swap is easy. Just measure the height of the reservoir from the pump from the donor car and match this in your Merkur. The reservoir comes with a metal bracket that is easily bent so that you can "adjust" it to fit the Merkur frame.

---

- Markings on original XR pistons by John in Seattle

**Q:** When I rebuilt mine it appeared that either A, someone at the factory was sleeping, or B, that my engine had been rebuilt once before, with one piston coming from a donor, as I had 2 pistons numbered "2".

**A:** Johnnie, if it was the pistons marked "2" and not the rods, they what you were seeing is likely the "piston class" done for select fitting the piston to bores which are also classed according to the size they end up when finish machined. Nothing is ever exact and the bore which are nominally 96mm end up a few ten thou this way and will be marked 1 or 2 and if you look at the flat near the dizzy holddown clamp there you'll see like 2222, I believe that's the bore class. The pistons are likewise marked and the geezers in Brazil, assembling just has to match a class2 bore with a class 2 piston top be perfect. The crank journals are also classed, usually "red" and "blue" and the bearings as well. Sometimes they are classed with letters A-B etc. My parents got a 1972 Cadillac and they graded pistons A thru M.

---

- Differences in Valve Covers between years by Jack Newman

**Q:** Wasn't there a problem with orifice size if someone changed the style of valve cover (there are two different ones right? - Mick

**A:** Turbo Coupe valve cover is not quite the same as XR4 cover. It has a lowered section in the center about where the throttle body is located. The hole in the back of the cover is 19 mm with rubber grommet vs. 10 mm without rubber on the XR4 (85). There was supposed to be a reason to change to the TC cover; clearance or splash characteristics or stronger or something, but I can't remember what it was. To use the TC cover you must have a TC separator. Mine fits loose too.

- 
- Timing the cam with a broken timing cover by Ryan Mattson

**Q:** I know there is a plate that tells you were to align the teeth for the timing belt but the three I have are broke and the person working on the car says there is no other way to align them. Does any one know another way or were I can get this plate or cover ?

**A:** There are actually 2 other good ways to align the cam.

1. The cam bolt, the pointer on the cam gear and the bolt on the auxiliary shaft will form a straight line.
  2. The cam bolt, the keyway on the cam and the crank bolt will form a straight line as well. Cam keyway pointing straight down basically.
- 

- Notes on changing the Timing belt by Larry Biles

Hi all. While we are on the subject of "cam timing", I thought that I would offer these personal experience "tips" relating to the procedure of changing the timing belt (& tensioner) on the XR. Let me say that the shop manual does a pretty good job of describing this procedure, and that one of the best how-to "write-ups" I've run across can be found at:

[http://www.turboford.org/faq/tim\\_belt.htm](http://www.turboford.org/faq/tim_belt.htm)

so....., I'm not going to cover the whole procedure herein, just offer a limited number of additional "tidbits" that I think people might find useful (these came to mind after I replied to Ryan Mackey's original question on "Cam Timing"; see below).

- 1.) The very first thing I recommend doing is to break loose the crank pulley bolt, the four fan pulley bolts, and the distributor hold-down bolt. (Doing this with the car in gear, emergency brake on, all the drive belts still tight, and with spark plugs still installed, is much easier!) Then "snug" 'em back up, but not too tightly. Now, when you go to remove them later on in the procedure, it won't be such a pain to break them loose!
- 2.) The manual describes how to get the engine to TDC (crank, cam, and distributor all in the correct place). To do this per the manual instructions, it is necessary to remove the round plastic plug from the outer timing cover so that you can see when the cam sprocket reference arrow lines up with the center mark on the tab inside. Be advised that it is not easy to get this plug out without breaking the brittle-with-age plastic retaining rim of the plug, thereby making it impossible to reinstall the now damaged plug. So, I used the wife's hair dryer to warm up the plastic plug, making it more pliable, then squirted a little WD-40 on it, and then ever-so-gently pried it out, using a very small tipped screwdriver. No damage, and plug was reusable.
- 3.) Once I had the engine at TDC, I removed the distributor cap and, using a felt-tip pen, I put a reference mark on the distributor outer rim right smack in the center of where the rotor was pointing (on a 5-spd., this will be 13d, and on an auto, 10d, assuming you had the timing set right in the first place!). When putting everything back together, once you're finished installing the timing belt, you can now easily see if you're in the ball park with the ignition timing, i.e., the rotor and your mark should line up. (I hit mine so perfectly that I didn't even have to loosen the distributor hold-down bolt to adjust the timing; it was dead on 13d!!!!)
- 4.) Now you can follow the rest of the timing belt & tensioner R&R procedure pretty much as described in the manual, etc.. (BTW, if you intend to reuse the spark plugs, mark them as to what cylinder they came out of for reinstallation in same.)
- 5.) I recommend that the cooling system be drained so that the thermostat housing can be removed--this makes it much easier to get the plastic outer timing belt cover off, plus, it affords you the opportunity to check and replace the thermostat. You'll be glad you did this when it comes time to remove the bolt for the cover that is behind the T-stat housing! (Now's a good time to think about replacing the water pump, too.)

6.) If you are going to be replacing the timing belt tensioner (highly recommended), be advised that there is a good chance that you will break off the plastic cam sprocket alignment tab from the inner belt-housing. All it takes is a "slip" of whatever pry bar device you're using to get the tensioner spring back in place and you'll probably hit this reference tab and snap it off! Now you're in trouble! So, I recommend that prior to removing the belt, line up the arrow on the cam sprocket with the center mark on the plastic tab, then use a good, sharp, center punch to put a mark on the top edge of the cam sprocket and a corresponding, exactly aligned/located mark on the metal belt-guide right behind the sprocket. Now, when/if you break off the plastic reference tab, you have a back-up way of timing the cam.

7.) Before removing the two alternator/power steering pump belts, draw a chalk mark (or such) straight across them so that you can put them back in-phase with their original/previous relative positions, so that they will take the same "set", preventing one belt from being looser than the other.

8.) Once you have the timing belt off, I highly recommend using a wire brush to clean up the grooves in the cam and auxiliary drive sprockets. (Get all the rust and possible old belt rubber "residue" out of there!) After brushing, I sprayed out the entire area (don't forget the nooks and crannies), and then wiped down everything to make sure there were no remaining particles, etc., that could wind up in the wrong place and cause damage/pre-mature wear to the new belt. (I'm so "anal" that I used Q-Tips! Ha, ha!)

9.) The manual states that you need a special tool/puller to get the belt pulley off the crank--but, mine just slipped right off with a gentle hand tug!

10.) Be advised that if you spin the cam sprocket around a couple of revolutions or so while you have the timing belt off, that you will pump the oil out of the lifters. So, be prepared for a little "racket", until they get pumped back up, when you fire up the engine when you're done. Best to "pressurize" the oil system before starting the engine!!

Well, I better get out of here; didn't mean this to be so long when I started out. Remember, these are just supplemental procedure "tips". Hope this info is of help to someone.

- What about the Timing belt tensioner by Larry Biles and Steve Kummerfeldt

**Steve notes:**

IMOP, you should always replace the tensioner. If the belt is due to be replaced, then the tensioner is also. No if's, and's or but's..

I agree that the tensioner pulley should be replaced, however it probably does not need to be replaced in the same 60,000 mile interval as the timing belt. I would recommend every 120,000 miles.

My tensioner pulley on my 1986 XR lasted to 180,000 miles before it started to squeak. A tensioner pulley on my 1990 Honda Civic recently seized at 310,000 miles!

**Larry says:**

I agree with Steve K. that the belt should be replaced every 60K miles, and the tensioner every 120K miles. But, if you aren't sure when the tensioner was last replaced (like you just got the car and don't have any maintenance records), go ahead and initially replace both at the same time. And, I agree with Dirk N. that you should use the Ford tensioner. But here's another tip for you; if you buy the "Cloyes" brand, available from O'Reilly Auto Parts (P.N. is 9-5011,) what you will actually find in the box is the genuine OE FoMoCo tensioner, P.N. F57E-6K254-AA stamped right on it!! \$32.99--try to beat that price at Ford!

BTW, I use the "Gates" No. T014 timing belt (square tooth), at about \$12 bucks everywhere.

- Ranger Roller cam Adjustment by Geoff Hemsley

What about 4 degrees retarded? I am running a T-5 from a 93 Mustang GT with the tall 5th gear and 3.64 stock rear end. I would be really happy with the best of both worlds. Is anyone running the RR cam at -4 degrees?

Its very beneficial to others for users of multi-index or adjustable cam sprockets to report their results with specific offsets and specific cams. However, I think the real benefit of these devices is that they allow one to do one's own experiments and decide on the optimum setting for oneself. After you've done it once or twice, the task of resetting a multi-index cam sprocket to a different setting takes under 1/2 hour easily and I highly recommend it as a means to finding your own preferred setting. Just remember to set your engine at TDC before you start disassembly, and double check the cam sprocket position at least once before you get too far into the reassembly. Also, be careful not to turn the distributor sprocket as you proceed, if it gets rotated at all you will have to reset your ignition timing.

By the way, if you want to experiment as thoroughly as possible while minimizing the number of iterations, try a "Newtonian search". In other words, start with three tests, at -8, +8, and 0 offset. Then try the offset in the middle of the two that were the best, e.g if -8 and 0 were the best, try -4 next. Then, if you decide say that -4 and 0 were best, try -2. Then choose the best of 0, -2 and -4 (if your butt or your G-Tech can really tell the difference).

- 
- Lots of white smoke by Steve Leiding

**Q:** so i blew out my valve seals right??? Just want to make sure before I start that im replacing the right parts. Thanks to everyone for the advise. Also what are the best valve seals regardless of price and where can i get them??

**A:** I replaced my valve stem seals about 5 years/30,000 miles ago with new replacement seals from Ford. I don't know if they are still available but they are a different design than the originals (which were completely fried), and they fixed my exhaust smoking problem completely.

**A:** They are still available and work the best...

E7ZZ6571-B Exhaust valve seals.

E7ZZ6571-A Intake valve seals

---

- Compression Testing basics by Travis

Miguel Molina asks :

**Q:** Hey Gang, I just brought a compression tester and I was wondering what is the correct way of testing and how much pressure should I expect to see from each cyl. I have an 88XR which has just hit 103000mi on the speedometer and is an automatic. I am curious to see what if any benefit there might be to running this kind of test. Thanks in advance for all your assistance.

**A:** Well compression is very indicative of your engines sealing ability, holding the "umph" to put it simply. It never hurts, might as well change the plugs while you're at it though, that won't hurt either.

The benefits are two things:

- 1) Assuring you, at least for some time that your head gasket/rings are ok and you aren't mixing coolant and oil into the cylinder head! Good thing.
- 2) If it's low or inconsistent, you are likely to have a leaky head gasket or head damage, in which something VERY apparent symptom wise will develop soon. Do not drive if this is the case. A new head gasket is much cheaper than new pistons and rings, etc...

#### PROCEDURE

Disconnect main ignition coil wire, center cap (so motor don't crank on ya!)

UNscrew spark plug, replace with screw-in fitting on tester connect gauge (if detachable)

Turn key to start car for about 3-4 rotations.

Watch gauge for about 30 secs checking for leak-down. It shouldn't.

Do individually for each cylinder, remember to replace each plug after checking.



Note Above 120 is good sign, below 110 not so good. 140 is very nice for 100,000K The lowest cylinder should be no further than 20% from the highest. I'd say 10% but the manuals say... Pbbt.  
IE: 125-127-138-135 Good, 110-95-126-135. Not good.

I think that is the basics. Please reply if something seems absent.  
Travis

- 
- Exhaust manifold Gasket and associated Part numbers by Mike Hughes

**Q:** I have a leak in the gasket between the turbo and the exhaust manifold. I have a gasket from an old felpro kit, but it is paper, and I thought the original one was metal (I haven't pulled the turbo off yet) does anyone have a part # for the correct gasket or advice on what is the best gasket to use on this ?

**A:** I just had some experience with this last week. In addition to a hole in the muffler of my original exhaust system, my exhaust manifold was leaking at #4 port and had eroded badly. FoMoCo still provides the parts:

Exhaust Manifold: E3ZZ 9430 A \$176.05 list  
Manifold to Turbo Gasket: E3ZZ 9450 A \$6.82 list (yes, it is metal)  
Turbo Stud Nuts: W 520103 5309 (this may be an ISUZU part#!) \$3.45 list  
Spark Plug Wires: E8PZ 12259 A \$44.08 list  
Turbo Outlet to Throttle Body Hose: E3ZZ 9F722 A \$80.22 list

The exhaust system is NLS. I replaced it with a MP Stage III 3" exhaust, which transforms an otherwise completely stock XR quite remarkably, and installs with little difficulty (once one figures out how the extra hanger fits!) and sounds great without being annoyingly loud at cruising speeds.

- 
- Cylinder head diagnosis and repair/refit by Dan

I find the head/manifolds/turbo too heavy and clumsy to effectively R&R as a unit. Accordingly, I remove the exhaust to head bolts and leave the manifold and turbo in the car. The intake manifold can be removed, but you will need to take out a couple of the bolts by feel, because they are hidden from sight.

Once the head is loose and the gasket seal has been broken, bolt a chain or heavy line to the head and pass a long 2X4 through to each side of the car. In this way, you and a helper can easily control the head coming off and on.

These heads often develop cracks at the valve seats, so wire brush these areas and magna flux the head before you waste you time with any work to it.

If there are no cracks, it is my recommendation that you pull the cam, followers and springs, so that the valve grind can be evaluated. If the valve seats and faces are shiny in narrow bands, simply lap each valve and seat with compound for a perfect fit. If there are problems with the grind, have a 3 stage competition valve grind done. My last bill for this work was only about \$60.00 when I did the tear down and assembly.

While the valves are out, consider begging or borrowing or renting and electric die grinder and cutting away the very ugly casting ridge below each seat and smoothing into the valve pocket. Be careful not to nick any of the seats. The head will then flow a lot better. Don't surface the head unless it is warped. You don't need a higher compression ratio, sounds like your problems started with detonation. A nice metal straight edge with a flashlight from behind will tell you if it is warped. You can also, clean and spray paint the head surface and then lightly run a long, fine file over it. Any low spots will show as unfilled paint. In any event, do you own checking and don't trust the machine shops, they always sell the resurface to "do it right!" A standard Felpro head gasket will do the job. If you have turned the boost up, consider a Felpro 1035 (stainless rings) but it will cost about 60 extra.

- 
- Leakdown compression test notes by Chad



Do a leak down and a compression test. It will tell you a lot, but also remember, you still could have bad valve stem seals which will cause bad readings on a leak down. During the leak down open the oil cap, and listen if you hear air in the valve cover it is probably the valve stem seals, if you can hear air in the crankcase,(dipstick tube) then it is the rings, if you hear air in the throttle body then it is the valves themselves.

---

- Engine Specifications from Service Manual
- 2.3 L Turbo Engine Specifications  
GENERAL SPECIFICATIONS (from the XR Manual)  
NUMBER OF CYLINDERS 4  
BORE AND STROKE 3.780 x 3.126  
FIRING ORDER 1-3-4-2  
OIL PRESSURE (Hot @ 2000 rpm) 40-60  
DRIVE BELT TENSION (1)  
CYLINDER HEAD AND VALVE TRAIN COMBUSTION CHAMBER VOLUME (cc) 59.55-62.55  
Valve Train Specifications  
VALVE GUIDE BORE DIAMETER 0.3433-0.3443  
VALVE SEATS  
    Intake 0.060-0.080  
    Exhaust 0.070-0.090  
    Service Clearance Limit 45  
RUNOUT LIMIT (T.I.R. Max) 0.0016  
VALVE ARRANGEMENT (Front to Rear) E-I-E-I-E-I-E-I  
VALVE LASH ADJUSTER BORE TEMPERATURE 0.8430-0.9449  
Valve Stem To Guide Clearance  
    Intake 0.0010-0.0027  
    Exhaust 0.0015-0.0032  
    Service Clearance Limit 0.0055 Max.  
VALVE HEAD DIAMETER  
    Intake 1.730-1.740  
    Exhaust 1.49-1.51  
    Valve Face Runout Limit 0.002 Max.  
VALVE FACE ANGLE LIMIT 44  
VALVE STEM DIAMETER (Standard)  
    Intake 0.3516-0.3423  
    Exhaust 0.3411-0.3418  
    (0.015 Oversize)  
    Intake 0.3566-0.3573  
    Exhaust 0.3461-0.3568  
    (0.030 Oversize)  
    Intake 0.3716-0.3723  
    Exhaust 0.3711-0.3718  
VALVE SPRINGS  
    Compression Pressure (Lb. @ Spec. Length)  
    Intake and Exhaust (Installed Load) 71-79 @ 1.52  
    Exhaust and Intake Valve  
    Turbo  
        (Closed) 71.3 - 78.7 lbs. @ 1.52 (317 - 350 newtons @ 38.61mm)  
        (Open) 151.9 - 165.9 lbs. @ 1.12 (676 - 738 newtons @ 28.45mm)  
    Free Length (Approximate) 1.877  
    Assembled Height 1-17/32" -1-19/32"  
    Service Limit 5% Pressure Loss @ Specified Length  
    Out of Square Service Limit 5/64 (0.078)  
ROCKER ARM (Cam Follower)  
    Ratio 1.4-1.6:1  
VALVE TAPPET, LIFTER OR ADJUSTER

Diameter (Standard) 0.8422-0.8427  
Clearance-to-Bore 0.0007-0.0027  
Service Limit 0.005 Max.  
Hydraulic Leakdown Rate (2) 2.8 seconds  
Collapsed Tappet Gap  
    Allowed 0.035-0.055 @ Cam  
    Desired 0.040-0.050 @ Cam  
CAMSHAFT LOBE LIFT  
    Intake 0.400  
    Exhaust 0.400  
    Allowable Lobe Lift Loss 0.005 Max.  
THEORETICAL VALVE LIFT @ ZERO LASH  
    Intake 0.390  
    Exhaust 0.390  
    END PLAY 0.001-0.007  
    Service Limit 0.009  
JOURNAL-TO-BEARING CLEARANCE 0.001-0.003  
Service Limit 0.006  
JOURNAL DIAMETER  
    #1 1.7713-1.7720  
    #2 1.7713-1.7720  
    #3 1.7713-1.7720  
    #4 1.7713-1.7720  
RUNOUT LIMIT 0.005 Max T.I.R.  
Out-of-Round Limit 0.0005 in. Max.  
Front Bearing Location (3) 0.000-0.010  
CYLINDER BLOCK  
HEAD GASKET SURFACE FLATNESS 0.003 in any 6" -).006 overall  
HEAD GASKET SURFACE FINISH (RMS) 60-150  
MAIN BEARING BORE DIAMETER 2.5902-2.5910  
DISTRIBUTOR SHAFT BEARING BORE DIAMETER 0.5155-0.5170  
CRANKSHAFT, FLYWHEEL AND CONNECTING ROD  
    MAIN BEARING JOURNAL DIAMETER 2.399-2.3982  
    Out-of-Round Limit 0.0006 Max.  
    Taper Limit 0.0006 per inch  
    Journal Runout Limit 0.002 Max.  
    Surface Finish (RMS) 12 Max  
    Runout Service Limit 0.005  
THRUST BEARING JOURNAL  
Length 1.2010-1.1990  
    CONNECTING ROD JOURNAL  
    Diameter 2.0465-2.0472  
    Out-of-Round Limit 0.0006 Max.  
    Taper Limit 0.0006 per inch Max.  
    Surface Finish (RMS) 12 Max.  
    MAIN BEARING THRUST FACE  
    Surface Finish (RMS) 35 Front 25 Rear (Max.)  
    Runout Limit 0.001 Max.  
    FLYWHEEL CLUTCH FACE Runout Limit 0.005  
FLYWHEEL RING GEAR LATERAL RUNOUT (T.I.R.)  
    Standard Transmission 0.025  
    Automatic Transmission 0.060  
CRANKSHAFT FREE END PLAY LIMIT 0.004-0.008  
    Service Limit 0.012  
AUXILIARY SHAFT END PLAY 0.001-0.007  
CONNECTING ROD BEARINGS

Clearance Crankshaft --Desired 0.0008-0.0015--Allowable 0.0008-0.0026

Bearing Wall Thickness (Standard) (4) 0.0619-0.0624

#### MAIN BEARINGS

Clearance Crankshaft --Desired 0.0008-0.0015 --Allowable 0.0008-0.0026

Bearing Wall Thickness (Standard) (4) 0.0956-0.0951

#### AUXILIARY SHAFT BEARINGS

Clearance to Shaft 0.0006-0.0026

#### CONNECTING ROD

Piston Pin Bore Diameter 0.9096-0.9012

Crankshaft Bearing Bore Diameter 2.1720-2.1728

Out-of-Round Limit 0.0004

Taper Limit 0.0004

Length (Center-to-Center) 5.2031-5.2063

Alignment (Bore-to-Bore Max. Difference) (5)

Twist 0.024

Bend 0.012

Side Clearance (Assembled to Crank)

Standard 0.0035-0.0105

Service Limit 0.014

#### CYLINDER BORE AND PISTON

##### CYLINDER BORE

Diameter 3.7795-3.7825

Surface Finish (CLA) 8-24

Out-of-Round Limit 0.0015

Out-of-Round Service Limit 0.005

Taper Service Limit 0.010

Piston-to-Bore Clearance (Select Fit) 0.0030-0.0038

##### SERVICE PISTON SELECTION (6)

Piston Bore Diameter Code-Service Piston Required

3.7764-3.7770 RED

3.7776-3.7782 BLUE

Pin Bore Diameter 0.9123-0.9126

Ring Groove Width

Compression (Top) 0.080-0.081

Compression (Bottom) 0.080-0.081

Oil 0.188-0.189

##### PISTON PIN

Length 3.010-3.040

Diameter

Standard 0.9118-0.9124

0.001 Oversize 0.9130-0.9133

0.002 Oversize 0.9140-0.9143

Piston-to-Pin Clearance 0.0003-0.0005

Pin-to-Rod Clearance Interference Fit

##### PISTON RINGS

###### 1. Ring Width

Compression (Top) 0.077-0.078

Compression (Bottom) 0.077-0.078

Side Clearance

Compression (Top) 0.002-0.004

Compression (Bottom) 0.002-0.004

Ring Gap

Compression (Top) 0.010-0.020

Compression (Bottom) 0.010-0.020

Oil (Steel Rail) 0.015-0.055

Oil Ring Snug Fit

Service Limit 0.006 Max.

Ring Gap

Compression (Top) 0.010-0.020

Compression (Bottom) 0.010-0.020

Oil (Steel Rail) 0.015-0.055

LUBRICATION SYSTEM

OIL PUMP

Relief Valve Spring Tension (Lbs. Spec. Length) 18.76-20.71 @ 1.172"

Drive Shaft-to-Housing Bearing Clearance 0.0015-0.0030

Relief Valve-to-Bore Clearance 0.0015-0.0030

Rotor Assembly End Clearance (Assembled) 0.004 Max.

Outer Race-to-Housing Clearance 0.001-0.013

Oil Capacity (Quarts U.S.) 5.0

Note: Dimensions in inches unless specified otherwise.

1. Newly Installed--Refers to the condition of the "NEW" drive belt before the engine has made no more than one rotation and before the belt has had a chance to stretch or seal into the pulley grooves.

2. Time required for plunger to leak down 1/8" of travel with 50 lb. load leakdown fluid in lash adjuster

3. Distance in inches that front bearing is installed below front face of bearing tower.

4. 0.002 undersize = Add 0.001 to Standard Thickness

5. Pin bore and crank bearing bore must be parallel and in the same vertical plane, within the specified total difference when measured at the ends of an 8" bar -- 4" on each side of the rod centerline.

6. When replacing pistons, measure the cylinder bore as described in the General Engine Section 21-01 and install the specified service piston as matched to the piston bore diameter above.

## Exhaust Stuff

---

- Glowing Exhaust Manifold by David Lockhart

**Norrin Asks:** The other day I noticed that my exhaust manifold was glowing cherry red, about the third cylinder back from the front (this was at night.) Is this normal? And when sometimes when I get into the higher rpm's it seems like the car starts to miss, like it is holding back. Thanks

**David Lockhart replies:**

A clogged exhaust could do this. Also a missing spout connector will cause a glowing turbo. This happened to me. Look at the wires that lead to the distributor, you should see a connector that is just hanging there. This is where the SPOUT connector, which is a little black "plug" that just sticks in there, goes. Without this plug the ignition timing gets all messed up for regular driving. I experienced a "power plateau" at highway speeds along with the glowing turbo phenomenon. Looking under the hood at night, and seeing that glowing turbo, was when I realized something was wrong, as well.

Check this first since it is easy to do.

---

- Oxygen Sensor Thread Size by Tim Roman

Oxygen sensor thread is an 18mm metric thread. The same as the "old" spark plugs. You should be able to find a thread chaser.

## Fuel System

---

- Fuel Pump relay problems by Frank Rice and others.

I recently had an experience that might be useful for all listees. My 85 was running good however one day it would not restart after a quick stop. Cranks fine, but no start. Check the spark - yep no TFI problem. Check the inertia switch - good. Turn on starter and no buzz up from the fuel pump. Check fuse, good. Check for relay click - NO CLICK - swap relay for a known good one, car starts right up. Drive the car for two days when suddenly no start and no fuel pump buzz. Pull relay (which is VERY HOT to the touch) and stare at it, push it back in place, and car starts right up! Two weeks later car does exactly the same thing. This time I decide to do more investigating, and actually fix the bugger. Following are symptoms and the fix:

### Symptoms

1. Car won't run or start or does so intermittently.
2. Fuel pump relay is VERY hot to the touch. Note that the fuel pump relay will always be warm to the touch as it is constantly energized when the car is running - we're talking can't touch hot here.
3. No 'click' felt when key is turned to start position.
4. No fuel pump buzz up.
4. Jiggling the relay or replacing the relay with a known good one (when cold) allows car to start

### Fix

Remove relay from the relay board - turn ignition off. With the help of a flashlight and using a jeweler's flat blade screwdriver gently close the spade terminals that are captive in the relay board that look like this .

There are four total, two tied into the ignition, and two that complete the circuit to the fuel pump - close up all four although it is probably just the two that energize the relay coil that need attention (that's why the relay doesn't go click).

What happens is that these terminals loose some of their tensile strength due to the heat cycles that they have gone through since new (these are old cars after all). Once they become loose, the contact they make with the spade on the relay is not sufficient such that the voltage goes down, and the ampacity goes way up (did I mention that the relay was VERY HOT).

By pinching the spade terminals back together, all problems go away. I also noticed that my car now runs much stronger than before - probably because I'm now getting full fuel pressure all the time rather than being dependent on the transfer pump in the gas tank. I'll bet a lot of good relays have been changed out because of this! Anybody else?

- More Fuel Pump relay comments by John Lofquist

Yes, LOTS of other people! Be aware that pinching the terminals back together is probably only a temporary fix. Here is what I did to solve it for good... First clean the terminals well - there is probably lots of contamination on them from the arcing. Then stuff some solder wick (small copper braid - avail at Radio Shack) into the hole on either side of the terminals. Makes for a nice tight connection with just a little 'give'.

- Fuel Pump relay problems and fixes by Lih-Yen

To add to that: 1. the backing could be restored by using some thickness of foil wrappers such as from gum sticks or cigarette boxes (oops) 2. the simple act of removing and re-inserting the relays a couple of times scrubs the corrosion off of blade surfaces \_and\_ creates new micro contact surfaces. Both are crunch mode operations but are just as effective. The reseating should also be added to your preventive maintenance (PM) list. Finally after the service rub a dab of tune-up dielectric grease down the socket openings. As for the reason of loss of backing my theory is due to the construction of the (fuel pump relay) socket blades. They were not fused/welded to a thick copper buss bar, as most others were, and so they did not have as good a mechanical backing as others did to begin with. (How many other sockets failed, ever?)



- More Fuel Pump relay problems and fixes by Aaron Loynes

Q: Okay... Those of you that read my first post about my odd electrical problems will know what I'm talking about... Today we attempted to diagnose the fuel pump problem and came to the conclusion that the problem was the fuel pump - and headed out to the parts car to get a new one... We got back and I attempted to start the car again and it just cranked but no start. Turned the key halfway on and the tach jumped all the way up then bounced around a few times and dropped down - I tried to start the car again after that and it started immediately. What the heck!?!?!? Well the car works... runs fine... started back up after i drove it and stopped... Any ideas what could have caused this? Battery terminals are clean, its a new battery and i sanded them down prior to installing the new battery. The ground straps are all intact. Maybe the alternator is malfunctioning?

- Still More Fuel Pump relay problems and fixes by Mike

Just short of putting the Merkur on some flatbed truck, I'm asking, as the last resort, for some help in tracking down problems with fuel pump. I've tested it with pressure gauge, no pressure. Then I attached a voltmeter to the pump, no voltages. I have the new fuse box cover from BAT and I don't think its exactly accurate, it shows NO fuel pump fuse and/or relay. I have checked each and every fuse, and none of them are blown. I've replaced all relays (just in case) from another XR4Ti, and the problem remains. Any pointers? On or off the list will be much appreciated. I've tried the archives but its not in easy-to-read format, unless I'm doing something wrong.

- Running the Fuel Pump to Drain Fuel from Gas tank by Dimitri Wittal

Here's a tip that works on any EEC-IV ford. You can run the fuel pump continuously straight from the EEC-IV test connector. Hold the connector so that the row of two pins is at top. Insert a wire into the rightmost pin on the bottom row of four. Turn the ignition on, then ground that wire. If the fuel pump circuit is operational and the inertia switch has not been tripped, the pump will run as long as the wire is grounded, because you have just grounded the fuel pump relay.

I have used this to drain gas tanks by disconnecting the supply hose from the fuel rail.

Walbro 255lph High Pressure pump.

- Additional Walbro Install notes by John Baas

After reading the articles in the Merkur Encyclopedia on how to install the High-Pressure pump, I thought "No problem, right?" This was mostly true.

Here are a couple of things I ran into:

Thanks to living in the Midwest, the bolts that hold the fuel tank in were nice and rusty, as was the top of the fuel tank, where the sender/pump assembly goes. I had to bend the tabs up slightly to get the unit to twist out. I followed the directions in the Service Manual. It's also a much easier job when the tank is empty (which mine wasn't).

After the tank and pump was out, you'll see just how much bigger the new pump is (I would have taken pictures, but I was covered in gas/grease/grime and didn't feel like handling an expensive digital camera) The stock pump is held in with two clamps, and there is a rubber insert between the pump and the clamps. I marked the new pump in relation to the bottom of the pump hanger. I then removed the old pump, bent the clamps open, put the new pump in, and used a large hose clamp to hold it in. The stock clamps are too small to be used. The pump outlet should be in-line with the metal tube. I cut the clamps off the hose on the pump outlet, cut it shorter, and installed new clamps. Now is the time to install the fuel sock. **DO NOT INSTALL IT BEFOREHAND.** The stock one is round, whereas the new one is rectangular, with the pump on one end, and not in the middle. If you look into the fuel tank, and line the tabs up, you'll see the pump sits next to a wall. When you put the filter sock on, make sure the sock does not hit the wall. I then changed the electrical connector.

I reassembled everything, and made my way to the inline pump area to remove the inline pump. I started to pull the lines to find out that the innards of the fuel line connectors were coming out and getting stuck to the pump and filter. Care needs to be taken so these parts are not damaged, and they go back into line connectors cleanly, or they will leak (ask me how I know) I went to Pep Boys earlier and had a 90 Ranger filter per the Encyclopedia. Turns out, this is not the filter you need, it is the same as the stock XR. I put the filter in place of the stock XR, then called the local dealer, referencing part # FOTZ-9155-A He said it doesn't exist. I asked if he had one for a 90 Ranger (in case the Purolator one was wrong) I went to pick it up, and he showed me the one he thought I was looking for. It looked the same as the XR/Ranger one, except the ends were about 1" longer on each side. Part number is FOTZ-9155-B (and it's not for a 90 Ranger) I grabbed it, and threw it in place of the stock pump (minus the foam between the pump and bracket).

Then it was on to the resistor wire. There are 5 (or was it 6?) wires coming out of the grommet on the trunk floor, above the pump area. 2 big ones and 3 (maybe 4) small ones. The big (12 gauge?) brown wire is the one you want. Just cut it, and run a wire to a ground somewhere.

Time to check for leaks. I must have had some dirt in one of the o-rings that came off, since I cleaned it, and reinstalled it, and the leak stopped.

When I turn the key on, I notice that my fuel pressure gauge jumps up really high quickly (45-50psi or so) then backs down to about 35 psi. I think I may have a bad regulator since I have about 5psi less of pressure than I think I should, but it was that way before the pump swap.

Hope this helps. I cc'd Allen so he can hopefully update the Encyclopedia.

- I have purchased several from Ron Gregory at Auto Performance Engineering:  
[syclone@home.com](mailto:syclone@home.com) [www.members.home.com/syclone/APE](http://www.members.home.com/syclone/APE) -- Steve Meyer
- I have purchased a couple from Ron as well. Another URL is  
<http://autoperformanceengineering.com>  
The kit you are looking for is for 85-97 Mustang. --John Baas

Message: 2 Date: Mon, 8 Oct 2001 12:39:23 -0600 From: James <[jamesw@telus.net](mailto:jamesw@telus.net)>  
Subject: 255L/Hr fuel pump success

Group, I just thought I'd share my 255L/Hr fuel pump upgrade experience on my '88 XR 5-spd with everybody. The fuel tank level sensor wasn't working either. Removing the tank is easy, there is a splash shield which is easily removed with a few screws, then two bolts (13mm socket) that hold the two retaining straps that hold the tank up. I put a floor jack under the tank to support it. Open the gas filler door and removed the three screws (8mm socket) that hold the gas cap, now the filler neck is free from the body of the car. I lowered the tank about a foot to gain access to the fuel supply/return lines and the fuel level sensor/pump sockets and charcoal canister hose. All are easily disconnected. Lower the tank on the driver's side and pull the tank away from the filler neck. The fuel pump and sender are attached to one unit that is removed by a simple lock collar. use a blunt screw driver and hammer to rotate the collar counter clockwise about 1/8th of a turn to release it. The unit just pulls straight out. I bought the pump from Ron Gregory at <http://AutoPerformanceEngineering.com> for about \$108, it was part number FP003 and came with all the parts you'll need to install it. I had to shorten the steel line because the new pump is a bit longer than the old intank pump. It came with an 's-shaped' fuel line which I cut down and used about an inch of and the two hose clamps provided. I also used a large hose clamp and the old rubber insulators to hold the pump to the old brace that used to support the intank pump. The pump also came with a new sock for the inlet. There was a small black box inline with the electrical wires feeding the pump inside the tank. This was a set of resistors which I cut out and tossed. The new pump comes with a new plug (different from the original) so that needs to be soldered in any way. This was all very easy and brainless. Next remove the pump and filter

located on the frame rail. I found the inlet line plugged right into a new fuel filter and the old outlet line easily plugged into that so no V6 Ranger filter was needed. That's it. I cleaned up the tank with some solvent and re sprayed the bottom with undercoating and the top with engine enamel (as it was originally). Installation was easy although I had a bit of a fight to squeeze the filler nozzle back in but a tight fit is a good fit. :)BTW the problem with the sender was that the float was filled with gas, a local gas tank shop gave me a replacement for \$10.cheers  
James

---

- Where to get Fuel injectors refurbished and flow matched by Mike Shaw  
I also have used [www.autoenginetech.com](http://www.autoenginetech.com) and highly recommend them.  
If possible send them 8 of them for much better chances of getting a very good set of 4 that match in flow.

- Fuel Injector repairs? By Don  
Here's where I get my injectors done, \$10 bucks a piece:  
[http://www.angelfire.com/pa3/lyzcoinc/clean\\_injector.html](http://www.angelfire.com/pa3/lyzcoinc/clean_injector.html)

---

- Weird Fuel pressure regulator failure mode by Dirk Nansen  
I just had an FPR failure that was something I have not heard of before though maybe I just missed it. On an XR, the FPR would work normally until the car produced boost and then it would just plug the bypass line so the pressure went over 100 psi and the car went way rich. Once that happened, it would stay that way, even at idle. In that mode, no fuel would come out of the return line from the fuel rail. The car would run reasonably well on closed loop but had no power in open loop. A new FPR solved the problem.

---

- Fuel pressure dampener leaking by G Higgs  
**Q:** Since I changed my oil pressure switch, the fuel line that connects to the pulse damper is leaking. At first I thought I had the wrong size clip (3/8 I think) so I got smaller ones (5/16) and still it's leaking. So once again my XR is grounded \*sigh\* Suggestions anybody???  
**A:** Inside that connector on the fuel line to the pulse dampener you'll find 2 (likely dead) "O" rings. Get a bag of 3/8" "O" rings from Ford. I wasn't happy with the Nitrile ones from NAPA. Too hard. It's a 5/16" line, but uses 3/8" rings. (another lesson...) Anyway, fish out the old "O" rings with a dental pick, or similar, and replace them. Might be a good idea to do the rest of them while you're at it, or the next time you're under the car (the other ones are not quite so easy to get to...).Hope that does it!

---

- Fuel injectors O-ring lubrication by Larry Biles  
Hi every one. When I got my new injector O-rings from Ford, there was an installation sheet in the bag that said to apply a light coat of engine oil to the O-rings before installing them on to the injectors. Additionally, page 24-29-23 of the shop manual says:"Installation"1. Lubricate the O-rings with light grade oil ESF-M6C2-A, or equivalent, and install two on each injector. NOTE: Never use silicone grease. It will clog the injectors. I would personally consider this info to be the definitive answer to the question. Thanks.

---

- Fuel Injectors Seal Replacement by William A Williams (Bill in Boulder)  
Having done this several times I believe that this is the easiest and best way to overhaul your fuel system. I hope that this will be of help to you and any others that might be suffering from the "Fuel on Manifold" syndrome. Do not delay in addressing the problem; a fire usually burns everything in front of the firewall!

No need to replace the injectors if it is the seal leaking. OTOH the injectors tend to develop leaks at the plastic metal interface that are unfixable. To get some clue before pulling thing apart you can use an engine cleaning gun or other means to thoroughly clean the manifold surface and dry it. Then wad paper towels around the suspect injector(s). When the leak is bad just pressurizing the system is enough but a quick blast at full boost will certainly cause the leak. A careful examination of the paper should indicate the source of the fuel.

The cause of the leak somewhat determines the approach needed to fix it. And several tools are a necessity. Pulling the connector from the injector requires that the latches on either side be lifted without breaking and I have never seen a factory tool to do this. A short wire hairpin

with the ends flattened and bent back and inward will do the job. You just have to make it from a coat hanger by hammering, bending, and filing. BTW do not assume that your mechanic has this tool; he just pulls until something breaks! The other tool is the correct releaser for the fuel lines; \$5 for the set!

Armed with the tools and the knowledge of where things are leaking first ensure that everything is clean around the manifold injector holes. Then unplug the injector wires, the coolant temperature sensor and the oil pressure sensor and pull the harness out of the way. Carefully as the insulation has gotten hard and brittle! Remove the fuel supply and return lines carefully too. Now remove the two 9(?) mm bolts holding the rail in place and pull it away from the manifold. Pull each injector out keeping track of it's location. Now wiggle the rail out. Some of the injectors may have little "c" spacers backing the seals to compensate for a misaligned rail. Keep track of where the are.

It is probably a good idea to check the alignment of the fuel rail as they are easily bent. After cleaning it up and making sure that the injector sockets have no deposits or rust clamp it with the cups up. Set a small marble or ball bearing in each cup; one just a little larger than the inside of the cup is best. Then use a straightedge or ruler to check the alignment in both planes. Straighten as required. The mounting system of the rail is problematic at best and the rail is easily bent. This is the main cause of leaking seals! Once the rail is straight then you can reassemble the system. New seals should be installed with a gasoline soluble solvent. Vaseline works well. Do not use any form of silicone grease! Reassemble everything onto the manifold trying not to bend or deform the rail. Reinstall the fuel lines, press the injectors into their sockets, tighten bolts and you should be there. If you are able to apply about 20 psi. air to the fuel pressure regulator you can test the system for leaks just by clicking the ignition switch to Run several times to run the fuel pump. This simulates running under full boost. Look closely for leaks or use the paper towel test. A remote claw pickup tool can be used to hold a section of towel to search for leaks. If no leaks are found then reinstall the harness.

The choice of injectors is open to discussion. Some people like the disc type and they are cheaper. Alternatives are also available from other sources but you must be sure that they flow the same rate at the same pressure. The original Brown/Gold top Motorcraft injectors are rated at 35 PPH at 39 psi. you may convert from other pressures by knowing that the flow rate is proportional to the square root of the pressure. That is to say doubling the pressure will increase the flow by 1.414.

- 
- Evaluating leaky Fuel Injectors by Larry Biles

**Rick Gunther asks:**

Is it easier to R & R the injectors? Or to clean them? What is the cost Of injectors? I think I can get a TFI at the junkyard and odds are it will act Differently so it might be a good way to pinpoint the broblem. Or like the sign at the yard says: Didn't need that part or it is not the right one.....Now you have a spare, No Returns! I did try a double strength additive for cleaning the injectors but don't think I "heat sunk" it to see if it was still doing it. I don't have a manual. I do have the Alldata.com disc but they are configured for TSB's and spec's so I cannot get the troubleshooting charts or repair procedures. I appreciate your help. I am going to get a TFI tomorrow and wait to hear about the injectors from you. This car is alot of fun to drive.

**A:** Note: Do this test on a COLD engine!!! I assume you have access to a quality fuel pressure gauge, since you work on trucks for a living. If so, attach it to the Schrader valve on the fuel rail, and turn the ignition switch to "on". The main fuel pump will turn on and pressurize the fuel rail, injectors, etc., to around 38 psi or so. Turn the ignition switch off, and watch the fuel pressure gauge reading. If it immediately starts to head for zero, you've either got a bad Fuel Pressure Regulator (FPR), or a leaking fuel injector. Proceed with the test procedures below. If the pressure stays full up for a couple of minutes, and then very slowly begins to bleed down, that's normal, and your problem is elsewhere (probably!).

To check the FPR, disconnect the vacuum line at the regulator (mounted on the end of the fuel rail). If the inside of the vacuum line shows any sign of wetness from gasoline, the FPR is \_definitely\_ bad. Stop here and go buy a new one at any auto parts store. If you don't detect any

wetness, connect a hand operated vacuum pump to the regulator fitting and apply 18 inches of vacuum. If the reading does not remain at 18 inches, the regulator diaphragm is leaking. Go buy a new one. If the FPR passes these tests, move to the next step.

Be advised that a leak from a fuel injector can be either "external", or "internal". "External" leaks cause engine fires, and have been the reason for the demise of many XRs!! (That's why I always carry a fire extinguisher in my XR!!) "Internal" leaks cause engine flooding (that whole scenario we discussed before), and poor gas mileage.

You can usually tell if you have an "external" leak, because the outside of the injector gets visibly wet when the fuel rail is pressurized (not to mention being able to smell the gas fumes). The fuel can be leaking out of either the small "weep hole" in the side of the plastic injector body, or an actual crack in the plastic body. This kind of leak cannot be repaired!! The injector is "toast"; replace it before your whole car becomes "toast!!" (I've got some good used spare injectors; let me know if you need one.)

Another possible source of an "external" type injector leak is bad "O" ring seals (2 per injector). This leak can be fixed by pulling the injectors, and putting on new "O" rings (do all 4 injectors, while your at it). The "O" rings are still available from Ford, P.N. FOPZ-9229-A, for around \$10 for a package of 10 (they give you 2 "spares" in the package). Or, you can just get aftermarket "O" rings at just about any parts store. While you're at it, also buy a package of the little plastic pintle caps that fit on the business-end of the injector--very cheap. (Sorry, I don't have a P.N. for these.)

As for an "internal" injector leak, failing the pressure-hold test described above, when the FPR tests good, is a dead give-away! To find out which injector(s) is leaking when under pressure, pull the spark plugs and look for the wet one. If you do have an "internally" leaking injector, it can usually, but not always, be fixed by cleaning the injector. The best way to clean the fuel injectors is to buy and use the special cleaning kit made by, I think, 3M. It is a pressurized 16 oz can of strong cleaning agent, with a rubber hose and fitting that you screw onto the Schrader valve on the fuel rail. To use it, you disable your fuel pump, bleed the fuel pressure at the Schrader valve, attach the hose to the valve, and start the engine. The engine will run off of the stuff in the can for about 10 minutes, and then shut down when the can runs dry. The injectors are now truly clean!! Unscrew the can from the Schrader valve, and re-enable your fuel pump. (You can buy this injector cleaning kit from almost any parts store for about \$30.) You can also have this cleaning procedure done by most any reputable garage, for about \$60.

Whew, Rick, my typing finger is getting tired, so I'm gonna sign off for now. I think that I've answered all of the "fuel injector" questions in your last email. Go ahead with your plan to try a new/different TFI module.

- 
- Walbro GSS340 Fuel Pump Upgrade Installation by Grayson of MC2Racing

There are two reasons for installing an upgraded fuel pump in an XR4Ti. The first reason is obvious - you need more fuel for your modified engine. The second reason is unfortunate - one of your fuel pumps died. Whatever your reason, the Walbro GSS340 255 liter per hour high pressure pump is a great choice. It's dependable, quiet (you cannot hear it running in an XR4Ti), and cheap! I purchased mine from J.D.'s Performance online at [www.jdsperformance.com](http://www.jdsperformance.com) for \$109. Anyway, I figured that I would create a write-up on the project in case anyone would like to perform this upgrade themselves. Basically, this procedure involves removing the two existing fuel pumps and replacing it with the GSS340, and then extending the high pressure fuel pump wiring to the fuel tank to control the new fuel pump. The old low pressure fuel pump wiring will no longer be used.

Chris - feel free to swipe this and post it on [www.merkurtech.com](http://www.merkurtech.com).



Recommended Items:

Walbro GSS340 Pump (255lph High Pressure)  
1' fuel hose  
25mm to 50mm hose clamp  
14-16GA butt connectors (blue)  
14-16GA ring connector (blue)  
12ft 12GA red stranded wire  
6ft 12GA black stranded wire  
Electrical tape  
Epoxy

Recommended Tools:

Wire crimpers  
Wire stripper  
17mm socket  
13mm socket  
10mm socket  
8mm socket  
Screwdrivers  
Jack  
Two jack stands  
Hammer  
Chisel  
Rags

Recommended Steps:

1.) If possible, remove as much fuel from the tank as you can. This can be done using a few methods:

a) Use a siphon pump through the filler tube to suck out the fuel into a gas can.

b) Disconnect the fuel hose from the return side of the fuel pressure regulator, and attach a separate fuel hose to carry the fuel to a gas can. Turn on the engine. Since so little fuel is used at idle, most of the fuel will flow out the return hose into the gas can. This, of course, only works if you don't have a dead fuel pump.

If you cannot remove most of the fuel from the tank, the tank will be VERY heavy when you go to lower it from the vehicle. In addition, several gallons of fuel could spill out when the tank is pulled away from the filler tube. Make every effort you can do empty the tank as best you can.

-----

2.) Lift the left rear seat bottom forward and remove the bolt that attaches the rear seat belt receptacles to the floorpan.

3.) Remove the left rear seat back by removing the four screws (two on each side) that attaches the rear seat back hinges to the rear seat back. Lift the rear seat back away.

4.) Remove the left rear side bolster by carefully bending the retaining tabs at the bottom and lifting the side bolster up and away.

5.) Remove the 2 screws retaining the left shock bolt cover and lift away the shock bolt cover.

6.) Pull up the plastic cover on the left rear seat belt mechanism and remove the retaining bolt.



- 7.) Disconnect the two spade terminals that connect to the rear speaker.
- 8.) Remove the screws retaining the left rear plastic side shelf \*including\* the 2 screws at the rear of the left back seat wall panel. Lift away the left rear plastic side shelf.
- 9.) Remove the seven screws that attach the rear hatch wall panel to the body. Disconnect the hatch light wiring and lift away the rear hatch wall panel.
- 10.) Remove the hatch floor cover.
- 11.) Remove the three plastic push retainers that secure the left rear hatch wall panel to the body and lift away the left rear hatch wall panel.
- 12.) Remove the stowed jack and tire iron.

-----

- 13.) Make sure that the vehicle has cooled completely. Fuel and hot exhaust pipes don't mix.
- 14.) Open the fuel door and remove the three screws retaining the filler tube to the body. Place the gas cap and screws aside.
- 15.) Raise the rear end of the vehicle and support it with jack stands.
- 16.) Remove the exhaust pipes \*if necessary\*. The fuel tank can be removed without removing stock exhaust pipes, but this may not be the case with an aftermarket exhaust.
- 17.) Near the entry point of the filler tube into the fuel tank, remove the bolt retaining the filler tube bracket to the lip of the fuel tank.
- 18.) Place a bucket, box, or other object beneath the fuel tank, leaving a 4 to 6 inch gap between the two. This will be used to support the tank as you begin to lower it.
- 19.) Remove the six screws retaining the fuel tank shield to the body.
- 20.) Carefully remove the two bolts retaining the fuel tank straps to the body. Support the tank such that it does not suddenly drop on the supporting object you placed beneath.
- 21.) With the fuel tank resting on the supporting object, use a small screwdriver to remove the two fuel clips at the fuel line connections at the top of the tank. Once the clips are removed, disconnect the fuel lines. Also disconnect the vent tube, the fuel pump wiring connector, and the fuel gauge wiring connector.
- 22.) Pull the fuel tank away from the vehicle.
- 23.) If the filler tube grommet remained on the filler tube, remove it and re-install it on the tank.

-----

- 24.) The in-tank fuel pump is secured by a large locking ring. The ring has several tabs sticking up. Using a hammer and chisel [Ed. Wood block might be a better choice so you do not create sparks] , carefully tap the locking ring counterclockwise until it releases. Alternate the tabs you are tapping on occasionally to help ease the release and to prevent damaging a tab.

- 25.) Lift away the locking ring, and remove the fuel pump assembly from the tank. A small screwdriver may be used to separate the pump coverplate from the tank in case the o-ring is sticking.
- 26.) Clean any rust and small pebbles that fall on the fuel pump coverplate's seat on the tank. Be careful not to let anything drop into the tank at all times!
- 27.) Remove the two spade connectors that connect to the top of the in-tank fuel pump.
- 28.) Remove the two small screws that retain the fuel pump to it's bracket.
- 29.) Separate the fuel pump and the rubber fuel hose from the assembly.
- 30.) Remove the dangling fuel pump wiring by snipping it away at the "through-wall" connector on the coverplate. Do not snip away the fuel gauge wiring!
- 31.) Drill a hole through the coverplate large enough to pass the new fuel pump wiring through it. Deburr the hole as necessary.
- [Ed. I drilled out two of the existing rivets on the electric feedthru for the old pump. They will fall out when drilled thru, and they leave a nice clean burr free hole. I passed the wires thru these two holes and then epoxied them in place to seal the holes and prevent vibration from tearing up the wires.]
- 32.) The new pump will now be placed where the old in-tank pump used to sit. Cut a section of fuel hose long enough such that the distance from the tip of the new pump outlet to the steel fuel tube is about 1/4". Slip the fuel hose over the pump outlet and slip that over the steel fuel tube.
- 33.) Attach the sock filter to the bottom of the new fuel pump such that the sock extends toward the rear of the vehicle. You may have to remove the pump from the fuel tube, affix the sock filter, and then stick the pump back on the steel fuel tube a few times to get it positioned properly.
- 34.) Tighten the hose clamps to the fuel hose at the fuel tube and the fuel pump outlet.
- 35.) Use a steel hose clamp to attach the fuel pump body to the bracket. If the 1/4" gap from the previous step was attained, there should be just enough pump body for the hose clamp to wrap around.
- 36.) Wrap a thickness of electrical tape (or otherwise cover the wiring) at the point where the wiring will pass through the coverplate. Try not to tape the wire inside of the tank - the gasoline may eat it.
- 37.) Install a grommet in the drilled hole that the wires will pass through, if possible.
- 38.) Plug the supplied fuel pump wiring pigtail into the fuel pump, and guide the wiring though the drilled hole.
- 39.) If a grommet was not installed in step 26, apply a large glob of epoxy to the fuel pump wires and the drilled hole. What we are trying to accomplish here is to prevent the wiring from moving around the drilled hole, which could rub the wires bare and perhaps cause a spark. Allow epoxy to dry.
- 40.) Carefully lower the fuel pump assembly into the fuel tank. Make sure you remember to install the o-ring.
- 41.) Place the locking ring over the fuel pump coverplate and use the hammer and chisel to tap it clockwise into position.

-----

42.) Using a small flat blade screwdriver, carefully remove the hairpin clip from the fuel line on the input side of the external fuel pump, and disconnect the fuel line. Have rags available, for gasoline will spill out of the fuel line.

43.) Carefully remove the hairpin clip from the fuel line on the output side of the external fuel pump and disconnect the fuel line.

44.) Carefully remove the hairpin clip from the fuel line on the input side of the fuel filter and remove the "S-shaped" fuel line from the vehicle.

45.) Remove the three bolts attaching the external fuel pump to the welded body bracket.

46.) Disconnect the external fuel pump wiring connector and remove the pump from the vehicle.

\*\*\*\* Now would be a great time to change your fuel filter!

47.) Connect the fuel line that used to connect to the input side of the external fuel pump to the input side of the fuel filter. Install one of the three hairpin clips that were removed to lock the fuel line into place.

-----[steps 48 thru 67 revised to reflect the more preferred method for wiring the new pump]

48.) Zip Tie the old fuel high pressure fuel pump connector to the body to keep it out of the way.

49.) Lift up the carpet in the trunk area.

50.) Find the wiring that goes to the fuel pump grommet (goes thru to the underside of car.)

51.) Follow the wiring bundle from the fuel pump grommet to the taillight area.

52.) Unwrap the wire bundle, looking for a splice between one of the brown ground wires and an "oddly flimsy" dark brown wire that runs parallel to the back of the car. This is a .560 ohm resistor wire that was used to prevent the old low pressure fuel pump from seeing a full 12 volts. Replace this length of wire (about 18") with a piece of normal wire of similar gauge (preferably brown J .)

53.) Wrap and secure the wiring in the taillight area and restore the carpet.

54.) Under the car, cut the existing connector off the end of the fuel pump wiring, its no longer used.

55.) Connect, or solder, the power and ground wires that come thru the connector from the fuel pump cover plate to the car body. PAY VERY CAREFUL ATTENTION TO WHICH WIRE IS THE GROUND. VERY EASY TO SCREW THIS UP.

56.) thru 67.) deleted by revision to procedures.

-----

68.) Lift the fuel tank up, allowing the fuel filler tube to enter the tank.

69.) Support the fuel tank with the bucket, box, or other supporting object you used during disassembly.

- 70.) Connect the pressurized fuel line to the fuel tank and insert the hairpin clip.
- 71.) Insert the duckbill clip on the return fuel line and connect it to the fuel tank.
- 72.) Connect the fuel gauge wiring connector and the fuel tank vent tube.
- 73.) If necessary, connect the fuel pump wiring connector.
- 74.) Make sure the fuel tank straps properly pass through the fuel tank shield, raise the shield, fuel tank, and straps, and insert the bolts that retain the fuel tank straps to the body.
- 75.) Install the six screws that retain the fuel tank shield to the body.
- 76.) Install the bolt that attaches the fuel filler tube bracket to the fuel tank lip.
- 77.) Install the three screws that retain the fuel filler tube to the body through the fuel filler door.
- 78.) Lower the vehicle to the ground.  
-----
- 79.) Install the stowed jack and tire iron.
- 80.) Install the left rear hatch wall panel, securing it with the three plastic push retainers.
- 81.) Install the hatch floor cover.
- 82.) Connect the hatch light wiring to the rear hatch wall panel and install the rear hatch wall panel, securing it with the seven screws.
- 83.) Install the left rear plastic side shelf, securing it with the screws. You'll have to slide the front edge of the shelf behind the left back seat wall panel.
- 84.) Connect the two spade terminals that connect to the rear speaker.
- 85.) Install the left rear seat belt mechanism, securing it with the retaining bolt. Make sure to install the round black spacer between the mechanism and the body, inserting the dowel into the hole in the body. Snap the plastic cover on the seat belt mechanism in place.
- 86.) Install the left shock bolt cover, securing it with two screws.
- 87.) Install the left rear side bolster. You may have to carefully bend the retaining tabs at the bottom to facilitate installation.
- 88.) Install the left rear seat back by installing the four screws (two on each side) that attaches the rear seat back hinges to the rear seat back.
- 89.) Install the bolt that attaches the rear seat belt receptacles to the floorpan.  
-----
- 90.) Partially fill the fuel tank. Four gallons of fuel should be fine. It is recommended that you don't insert too much fuel, just in case you have to drop the tank again for any reason.

91.) Prior to turning on the engine, you can pressurize the fuel system by turning on the ignition for a few seconds, thereby letting the fuel pump cycle, turning off the ignition, and repeating several times. Or, if you would like, you can simply crank the engine for ~15 seconds until the fuel pressure builds and the engine fires.

92.) Once the engine is running, check underneath the vehicle for fuel leaks.

Grayson  
mc<sup>2</sup>racing

---

- Walbro GSS340 Fuel Pump Upgrade Procedure Addition by Ian Glyn-Jones  
Excellent write up, Grayson. However there is one mistake. You do NOT need to extend the wiring from the high pressure pump to the rear of the car to power the new pump. The factory wiring to the in-tank pump has a resistor wire spliced into it just inside the car by the right tail light. All you need to do is cut open the harness in this area and locate the thick brown resistor wire. Cut it near the floor where it the splice is and then splice in a short piece of regular 14 gauge wire then connect that directly to ground. You will now get full voltage to the in-tank pump. Note that the original in-tank pump would work as a high pressure pump in this configuration but would be very limited in supply due to its physical size. Lastly, remove the original high pressure pump from under the car and one short dogleg fuel line. There is enough slack in the other line to reach the end of the fuel filter. The old thought of using a Ranger fuel filter is not required.

Ian Glyn-Jones  
The XR Connection  
Ontario, Canada

---

- Table of OEM Fuel Injectors and the cars they came in

<http://www.geocities.com/ttskip/injector.html>

---

- Anti Slosh board removal by Larry Biles

**Q:** Hi guys, I removed the slosh board with no problem, great advice thanks. Unfortunately it didn't fix problem, any suggestions on where I can find a sending unit.

**A1:** I've had so many guys ask for more info on this that I decided to reply on-list with the how-to details. The anti-slosh board is the small (~ 11/2" X 21/2" in size) PC board velcroed to the back of the instrument cluster. It has 4 wires connecting it to the instrument cluster. The colors are:

RED (+10V input from the Instrument Voltage Regulator)

GREEN (Input from the fuel level sender)

YELLOW (Output that drives the fuel gauge)

BLACK (Ground)

First thing to do is, before you start, remember where each wire is/was connected, in case you want to put the anti-slosh board back! (Why you would want to put it back, I don't know!) The idea is to disconnect ALL of the wires, and then permanently remove (de-velcroize < good one, huh?) the anti-slosh board from the back of the instrument panel. (I pitched mine in the garbage!)

I'm not going to fully detail the procedure for R&R 'ing the instrument panel; most of you can probably do it in your sleep! I do have a couple of suggestions for you though, to make things go smoother and faster.

1.) Go ahead and remove the kick panel and lower dash cover; gives you better access to the speedo cable.

2.) Be very careful not to hit the hazard lights switch with the instrument panel, while you're R&R'ing it. (These aged, now brittle, plastic switch mechanisms are so "delicate", that one slight accidental bump and you'll likely break it.) Once you have the instrument panel out, you will readily recognize the anti-slosh board. (Again, it is simply velcroed on to the top, left side of the instrument panel, like the "after-thought" it was!)

3.) Unplug the red wire at the electrical connector "joint" (don't worry, you'll know what I mean when you see it).

4.) Remove the nut from the terminal where the black wire is connected. Remove wire. Put nut back on terminal.

5.) The green and yellow wires are connected to the same terminal, with a plastic "insulator washer" between them. Remove nut. Remove both wires AND the plastic "insulator washer". Put nut back on the terminal.

6.) Remove (de-velcroize) the now electrically disconnected anti-slosh board from the instrument panel.

Put everything back together. Remember, watch out for that hazard lights switch! (I bet you're glad you took off the lower dash cover now; that speedo cable is next to impossible to reconnect from the top!) You're done. Turn ignition key to "on", and watch the gauge needle climb up the scale! YEEHAW!!!

NOTE: (Yeah, this is the obligatory disclaimer!) Do this procedure at your own risk! It is merely my humble opinion, that you will not hurt anything by doing this. The gauge will work with the anti-slosh board removed, unless you have a bad sender at the gas tank (unlikely, but possible), or some weird wiring problem. I got this procedure from the many other people who successfully fixed their wacky gas gauges this way.

**A2:** Did you follow the anti-slosh board removal procedure EXACTLY? The two things that most people get wrong is that they don't put the nuts and washers back on the terminal posts after removing the wire(s)--these must be put back on. Secondly, and more commonly, lots of guys fail to remove, and leave off, the plastic spacer between the yellow and green wires on their shared terminal--you've got to remove and leave off this spacer!! If you got all of this right and the gauge still won't work, then you may indeed have a bad in-tank sender, although I've never heard of anyone else having one. Do you have a shop manual? If so, there is a good troubleshooting section in there to help determine exactly what component is bad (i.e., sender, wiring, gauge, etc.). I don't know where you can get a new/good in-tank sender, but I'm sure one of the other guys will provide you with a lead on that.

- Fuel Tank seal part numbers by Ian Glyn-Jones

**Q:** Hi all I am having trouble keeping my gas tank from leaking. The person I bought my '87 auto XR from installed a new in tank fuel pump and didn't reinstall the gasket. I tried to find a new one with no luck, but I did get some material to make a new, hope it works. My question is if this doesn't work where can I find the correct gasket? I have tried NAPA and advance auto, Ford was closed.

**A:** Here are the part #'s for the gas tank lock ring and "O" ring

"O" Ring E1VZ-9417-B \$1.25

Lock Ring E6AZ-9C385-A \$14

These are Canadian prices so they should be almost free in US currency ;-)

- Fuel Line Clips ? by Unknown

**Q:** Where can I find replacement fuel line clips ?

**A:** I just did this, your local ford dealer has them in 4-packs for \$2.92 if you are nice they might open it and give you the 2 for the filter. the p/n on the pack is N806191-S1901 RETAINER. Some times they are called the "hairpin style". Hope this helps. And for anyone else heads up, the Fram fuel filter at wal-mart p/n G3802A listed for xr4ti's has the clips with it for \$8.72. Too late for me but help yourself.

**A2:** NAPA stocks them. I replaced ALL of mine, and all the "O" rings in the hoses when I did my Walbro upgrade. Cheap peace of mind. Go to Ford for the "O" rings... The 5/16" hoses (supply) use 3/8" rings, and the 1/4" lines use 5/16" rings. Napa has "O" rings, but they're nitrile, and too



hard/stiff for the fuel lines... Hook the old ones out with a dental pick. You'll be surprised how ratty they are.

---

- Measuring Fuel system pressure by Dave Planakis

**Q:** Joshua Cooke asked " just chasing what the correct fuel pressure is before the fuel pressure regulator. I may have a dud fuel pump or crimped line. Thanks "

**A:**

In an XR and in all fuel injection systems that use a fuel return line the pressure is measured before the fuel pressure regulator. In an XR the fuel system goes like this:

fuel tank

in tank pump (low pressure/high volume)

rail pump (high pressure)

fuel filter

fuel dampener (the round thing next to the dipstick)

Fuel rail with injectors teeing off it

fuel pressure regulator

fuel return line to fuel tank

The fuel pressure regulator is a variable restriction devise

The greater the amount of restriction (smaller opening) the less

fuel will be returned to the fuel tank and the higher the fuel pressure will be

The smaller the amount of restriction (large opening) the more fuel will be returned to the fuel tank and the lower the fuel pressure will be. If you measure fuel pressure at the Schrader valve port

you are seeing the amount of pressure from the output side of the rail fuel pump all the way to the fuel pressure regulator. The round piece in the fuel line next to the dip stick is a fuel pulse dampener use to quiet the injectors. Don't confuse this with the fuel regulator which is located by the alternator. I hope this helps

---

- What does the carbon canister do? by Jake Delgado

**Q:** Can anyone tell me what the intended function of the carbon canister is? There is almost nothing in the shop manual regarding it. Is it really useful, or can it be deleted? Does it need to be serviced or replaced, if it is necessary? I doubt the carbon in my 86 is still absorbent. Thanks.

**A:** The purpose of the canister is to contain fuel vapors that would otherwise be vented to the atmosphere until they can be burned by the engine. The canister will last a loooooong time. I got a practical demonstration of this last year when I had a canister purge solenoid go bad in my '88. I was getting fuel smells from under the hood all the time with no evidence of a leak. I ran codes on the car because I was having a rough idle problem (turned out to be the MAP sensor) and the bad solenoid had generated a code. I replaced the solenoid and the fuel smell was gone, so the canister is still doing its job even though it is the original unit.

## Heating

---

- Heater valve theory and practice by Lih-Yien

There are two parts to heat control. The first one is with the hot water (heater) valve, which switches the hot coolant flow to the heater core on and off by way of a vacuum signal toggled by the temperature control lever. When the temp control is set to hot, no vacuum signal is present, no coolant flows through the valve to the core (but the coolant continues its flow to other segments in the bypass circuit.) This operates more like an on-off switch (binary).

The second is the amount of air that flows through the heater core. This is also controlled by the same temperature lever, but instead of via vacuum, it uses a Bowden cable to move an air door. This part is analog, similar to audio volume control.

Ideally you would want to have both functioning. The idea of bypassing the hot water valve is to constantly supply hot coolant to the core, relying the control solely on the Bowden cable actuated air door to regulate the amount of heat the circulating air extracts from the core.

The hot water valve may restrict the coolant flow somewhat but it may very well be a popular myth. Looking at the valve body, and the heater core inlet and outlet tubes, I could not see that much a difference in the cross sectional areas. Since the coolant in that (bypass) branch circuit also cools the engine oil (via oil cooler) and the turbo (via turbo cooler), and these three devices are configured in series when the heater is on, if either passage/segment in the circuit is clogged you will see reduced flow at the valve. To minimize clogging, I would use distilled water to dilute the coolant following a thorough flushing.

I think Ford must have committed to this dual control design for a good reason, just that is something I have yet to figure out. Yes, retaining the valve does require more diligent cooling system maintenance practice by following the main and bypass circuit flushing procedures, and it does make the hose connection pretty ugly looking and expensive. But even though in a crunch I would be willing to bypass the valve, when money becomes available, I would put the valve back in the circuit, unless I can be enlightened to see why the dual control is absolutely redundant.

---

- Heater core troubleshooting by Tom Manning then Jake Delgado

**Q:** Hi all, I get decent heat from My '88 Scorpio, but it is uneven. The air coming out of the passenger side vents is hotter than the heat coming from the driver side vents. What could be the possible cause? mode door sticking or not working? Doesn't make any difference if the unit is in auto mode or if I manually direct the air where I want it, fan speed does seem to affect the air temp. It takes the nip out of the air and defrosts the windows, but a little more heat wouldn't be a bad thing here in the mitten state. Any and all ideas are always welcome, thanks.

**A:** I notice the same thing on mine, but it's only a slight difference. If you're not getting pretty hot air past the core, it would probably seem worse.

There are several systems that need to be right. The air temp blend door needs to close tightly. The EATC needs to know the temp is low. The core needs to be hot.

I'd start at the easiest spot- check that the inlet hose for the core is hot. The outlet hose should be a little cooler, but cold means it's not flowing water.

After that, it could be the blend door or EATC (making the blend door open slightly). Set it on 99 degrees. There's only one flow of air, once inside the heater box. So, differences in outlet temp have to be duct work or air leaks.

**Q2:** For some reason my 88 Scorpio is having heating problems. Last winter it was fine, but now it warms up, but that's about it. It's only barely hot when it's on low, but once you turn it on high there's just nothing there but cool air.

**A2:** You probably have gunk clogging up your core. You will have to disconnect the core from the heater control valve and flush it in both directions several times. You will see a lot of crud come out of the core, especially if it has never been done. You can verify the heater valve is operating (and clear) when the hoses are disconnected by applying vacuum to the valve. If the valve moves internally when applying vacuum and doesn't leak vacuum, it is okay. If the diaphragm is bad, the valve will default to heat all the time.

---

- Heater core source by Dave Compton

**Q:** Anyone on the list know of a good source for a remanufactured heater core for an XR? I checked out BAT but they want about \$169.00 ...call me cheap...well ok...call me cheap...but I still think that's on the high side...

**A:** <http://www.heatercore4u.com/2-756.htm> \$138 (new)

Same unit as the Scorpio, apparently.

---

- Non-Functioning Recirc door causing Lack of heat by Ian Glynn-Jones

**Q:** On advice from a list member I checked to see if i heard the "clunk" of the recirc door . I heard nothing, used to hear it as soon as I started my car. I did not realize that i had stopped. what can I do to get this working so that I can keep this from causing my lack of heat problems. ?

**A:** There is a vacuum solenoid on the right fender well just behind the starter solenoid and above the vacuum reservoir. These are very common to fail. You can replace it with any vacuum solenoid. If you have a spare EGR one from the left fender, that will work, or you can search at the wreckers on Toyotas and Mazdas. They both had similar units. They may look different but will work fine. While you are replacing the solenoid, check all the vacuum hoses in that area and carefully check the vacuum reservoir. There is a check valve in them that is known to fail and cause the air door to open & close under accel/deccel. -Ian Glyn-Jones

**A2:** You may also have luck looking at other makes. One listee have reported finding similar looking parts that served the same function in late 80's Cadillac DeVilles and a late 70's Mercury Zephyr.

**A3:** Or you can buy new. Go to a Motorcraft supplier and get a DY-509. Remove the old solenoid from the mounting bracket cut the end of the bracket so it forms a C instead of a box (this is the end opposite the mounting hole) slip the new solenoid into the bracket and you are done. The price is fairly steep at

around \$60 (from memory). From the Ford box containing this part here on my desk, the part number seems to be 85GB-19496-AB, and the name is "Valve-Air".

**A4:** hey were able to cross reference it with their more complete Ford numbers. It's actually an E7GZ12A170B. This part is the vacuum solenoid for an '87 Mercury Tracer.

---

- Outside Air Solenoid by Dave Planakis (also see above info)

**Q:** Should I have outside air coming thru the vents all the time ?

**A:** No, you should not. See above post regarding "recirc. Door)

---

- Vacuum Reservoir Function Test by Jim Gosses

**Q:** I'm in the process of replacing vacuum hoses & solenoids etc... I have a spare vacuum reservoir and was wondering if anyone know how to test these?? I have a vacuum test gauge and found that if connected to the small inlet, it holds a vacuum and while connected to the large inlet and plugging the small inlet with my finger it holds vacuum.... comments?? - Steve Murray

**A:** The vacuum reservoir's purpose is to provide a constant vacuum source for the heater controls that is not affected by varying engine speed. Therefore it has an internal check valve. This often fails, symptom being that the heater fresh air door will open and close when you accelerate and then let off the gas. Therefore to test it I would put a vacuum gauge on the output side ( towards the heater controls ), with a vacuum pump on the input apply about 15" of vacuum, note the reading at the output, disconnect the vacuum pump and observe how long the vacuum at the output holds. It probably won't be perfect but should hold for a short while. -Jim Gosses

---

- Blower motor replacement procedures by Jon Lofquist

**Q:** I was wanting to know if anyone can give me an idea on how to replace the heater blower motor in my 85 XR4Ti.

**A:** The bottom line is that removing the blower "by the book" is a long, complicated process involving removing no less than the valve cover, ac lines, and part of the firewall. Last I heard it was six hours shop time, not including the ac purge/refill. But if you want to keep your XR pristine, that is the only way to go. Another method is much faster but requires some surgery. Remove the windshield cowl to expose the blower box. Remove the resistor pack and open the rectangular "inspection" window on top. Take a bare hacksaw blade and cut from each rearward corner to the

side and down to where the top of the box meets the bottom. Pry off the clips that hold the top and bottom together. They are all around the side and front. To get the front ones you will need a long screwdriver because they are right up against the firewall. Lift off the top. Replace the blower. Replace the top and seal the hacksaw lines with a sealant - I used a black rubber glue. Then cover that with some good black duct tape. Put back on as many clips as you can. Reassemble the rest. You will be the only person that can see the duct tape underneath and even then you will need a flashlight. Even with me being very careful, I did this whole procedure in less than 90 minutes on my last XR. I'm pulling all this from memory, so everyone out there correct me if I've missed something.

---

- Boost in Vents by Jim Gosses

This most likely is due to bad check valve in the vacuum reservoir, if you have a car that has had the CAT replaced on the recall by Ford then there is an easy way to test/and or repair it. When Ford did the CAT recall they also installed a check valve on the EGR line. You can remove this and plumb it into the heater reservoir line between the vacuum tree and the reservoir ( just make sure you get it the right way so that it retains pressure in the reservoir), if your problem goes away you can either leave it there ( recommended) or replace the reservoir ( BAT has them ). I left mine there and have the EGR as originally( before recall ) connected, have observed no negative impact, it might even run better.

---

- Scorpio Blower motor diagnosis by Johnny

**Gene Brady asks:** My wife's 1988 Scorpio's heater has decided not to work. The fan gave no signs of problems (i.e. squealing, grinding, only 1 speed working) until Sunday afternoon when it stoooped working. I checked all the fuses I could find. Is there an inline fuse? What is the easiest way to get at the blower tom test it?

**A:** This is the heater blower motor, as I understand it? If it is you need to check the fan itself and the blower control module (BCM). The BCM is located on the underside of the cover for the top of the evaporative case. There are three screws that hold this cover (it is black and is about 2.5in, by 6in) and then you can pull it off. Disconnect the 5-pin connector, and set the BCM aside. On the connector, connect one end of a jumper wire to one brown wire, and the other end to the negative battery/chassis ground. Then connect one end of a jumper wire to the battery positive terminal and then connect the other end to the red wire NEXT the brown wire. if the fan does not run, try the other brown and red pair. If the fan runs then you probably need a BCM. Roger Jones can remanufacture these for \$75.00, I think. Or you can order a new one from [www.opmd.com](http://www.opmd.com), or [www.batinc.com](http://www.batinc.com) (over \$200.00). Check the fuses in the fuse box first, they are the only ones I know of. I have no idea how to test the BCM itself. Hope this helps, I did not have this info when I did the one on my wife's Scorpio and I bought a fan first (\$225.00). Then found it was the BCM.

---

- Heater Core source by Dave Baylor

Anybody in search of a heater core for an XR should check out this web site. The business is Fisher Radiator in Mars, Pa . Phone #724-625-3370

---

- Blower transistor source by Steve Roberts

Mouser Electronics (800)-346-6873

=====  
Part No: 511-2N3055

2N3055 NPN power transistor (TO-3 package) \$1.24

Part No: 511-2N3771

2N3771 NPN power transistor (TO-3 package) \$2.26  
=====

---

Blower Motor Source by Fritz Knapp

I have been searching for a supplier of blower motors for my XRs and Scorpio. I have had offers from well known Merkur parts suppliers that most of you are familiar with from list references or personal experience. I am not going to list their names. The range of prices has been approximately \$250 plus shipping. Carparts.com has it for \$139 plus shipping. Now if anyone wants to pay those kinds of prices I'll be glad to sell these motors to you. I'm not inferring that

anyone is trying to get rich, just that maybe they need to research suppliers to get the best wholesale price so they can compete on the open market.

Here is the information:

Your local Autozone. New, not rebuilt, blower motor with attached blower fans. Limited Lifetime Warranty.

Part #224694 Manufacturer, SIEMENS VDO

Information on the box it came in...

SIEMENS VDO

Blower Motor

PM 3534

Assembled in Germany

Ford (sticker)

! Stueck/Piece

6167199

Motor

86 GG-185656-CA

PRICE: \$98.99 plus your local tax

## Ignition system and EEC-IV Engine Computer

---

- Aftermarket TFI modules by John J. and Henry

**Q:** Are there any good brands, I am considering a Philco TFI module.

**A:** The ONLY one I have faith in due to experience is made by KEM. My oem Motorcraft TFI blew out in 4yrs @ around 50k miles. The KEM I replaced it with was still going strong 11yrs later w/90k miles on it. Either the KEM#E317 or #E321 will be the right one for your car. [www.kemparts.com](http://www.kemparts.com) has both an online catalog & dealer locator that goes by zip code on their website. But if yours has checked out, I wouldn't run out & buy a new one just yet. Bad ignition modules usually show themselves in two ways. They either blow out completely leaving the car stuck, or will make the car park itself after running, then the car will restart after cooling down a bit

**A2:** My son went to Kragen's and bought a TFI unit for his 87 Ford Ranger 2.3 Truck. It was half the price than if you ordered for an XR.

---

- What is the LA computer ? by Dan

**Q:** All of the LA series ECUs work well in Merkur XRs. These would include LA, LA2 and LA3. I have used the LA2 and LA3 and they both perform about the same. Word is that any differences are pretty much emission related. Often LA2s are much cheaper because everyone thinks they want an LA3! Basically, these ECUs have twice the memory, they support ACT sensors for intercoolers, they have more aggressive timing and fuel curves and they will substitute valid values if sensors go out.

They require a pin relocation procedure at the connector and the big VAM should be used.

---

- TFI Module Troubleshooting notes by Richard Curtis

I hope this helpful to all; I haven't read this before on the list and didn't know it. Perhaps it will help all of us:

I just bought a new coil (KEM Manufacturing Co., Inc., 18-35 River Road, Fair Lawn, N.J.) for my 89XR. In the box were some instructions on troubleshooting TFIs and coils. Here's what it said:

Early Ford O.E. modules stamped "Made in France" are subject to premature transistor failure. This is due to poor soldering of the transistor to the heat sink.

All distributor-mounted modules are subject to premature failure if:

- they are not properly mounted on a clean surface.
- The heat transfer compound is not properly applied.

Some Ford distributor modules may become damaged by water. The water may originate from several places including:

- rain getting under the hood
- leaks from the cooling system
- or steam cleaning the engine (never aim the cleaner nozzle directly at any electronic component)

--Check for broken wire leads, when the pick-up coil has an intermittent problem. Read the resistance of the pick-up coil. The resistance should read between 650-1,300 ohms. During this check, wiggle all wires to see if any variation in resistance exists. A defective pick-up coil will show a variation. Check the magnet in the coil for cracks. This may also cause intermittent performance or "no start" problems. All Ford vehicles equipped with TFI-IV use a Hall Effect Unit in place of the pick-up coil. ... Ford has experienced a number of heat-related problems with this unit, including "no start" conditions when the unit is hot.

Replace early Ford Hall Effect Units (Ford # DU 30 - black color) whenever a module is changed. Ford's second generation unit (Ford # DU 30A - blue color) should be replaced whenever there is evidence of burning or heat at the connector where the module plugs into the Hall Effect Unit.



A TFI module can fail prematurely due to high primary current. Check the coil's primary resistance whenever any component is replaced in a Ford TFI system. If the coil resistance reads below 0.5 ohms, replace the coil. (to check: pull off the wiring connector on back side of coil (driver's fender)... attached DVOM leads, one to each connector. Read resistance in ohms... should be between 0.5 and 1.0 ohms)

High voltage leakage can also cause a TFI module to fail prematurely. Whenever a car with a TFI system is tuned up, check the coil winding area for "halo" marks. These indicate high voltage leakage. High voltage leakage develops when a vehicle is run for an extended period with a high spark plug voltage requirement. This is usually caused by a worn out spark plug or one or more open plug wires. High voltage leakage can cause many problems including radio static and ignition failure.

All 1985 Ford vehicles equipped with Thick Film Ignition (TFI) may also develop problems with the wiring harness connector to the ignition module. The connector uses a gasket built into the connector. In some cases this may cause the connector to seat incorrectly or "walk out" as the engine vibrates. This problem can occur while the car is being driven or it may cause a "no start." If the car does not start, check for this problem by pushing in the connector. If the car now starts, replace the connector.

All Ford vehicles equipped with a tachometer may experience a short out in the wiring harness. A short out may cause damage to the wiring harness, ignition coil or ignition module.

Summary: Whenever any parts are replaced in any Ford TFI system, you must check for all of the above problems to prevent the new part from being damaged.

- TFI Modules keep going bad ? by Duane

**Q:** Have you given any thought as to why you have destroyed two TFI modules? How long did they last? Was everything else on the electronics side of the car working ok prior to their failure? "Indestructible" is a relative term vis a vis most other components of the car that will fail before the TFI.

**A:** I had a problem with TFI's on my XR about ten years ago. I don't remember who, but, it was explained to me that the XR's had a problem with the insulation breaking down on the pick-up for the "hall effect" stator, which is inside the distributor. The insulation breaks down, the wires short out and catastrophically damages the TFI.

I took my distributor out and carefully inspected it, to find that the rubberized coating had fallen apart. I took the distributor apart and replaced the stator pick-up as well as the TFI. It has been about ten years and I have not had a problem since. I don't know if this is your problem, but it solved my TFI problem.

- Setting Ignition Timing by Richard Curtis

If you're mechanically sharp enough to install new plugs, distributor cap, etc., you can set timing. For the price of having someone else do it, you can easily buy a nice timing light that will last you a lifetime.

You'll need to access the hold-down bolt (sorta hidden between the distributor and the engine block, but accessible either with a wrench from the front of the engine, or by a socket-ratchet with a medium-length extension from the top; this is the hardest part by the way), loosen it so that you can turn the distributor. Remove the SPout plug. Hook up timing light according to the directions. Start engine. Pull the trigger on the timing light and aim it at the crank pulley. The strobe effect will illuminate the pulley and you'll see the timing marks. Turn the distributor until you get 10 degrees BTDC for an automatic-transmission car, or 13 degrees for a manual. Tighten bolt. Recheck timing one more time to make sure distributor didn't move while you were tightening the hold-down bolt. You're done. It might help to clean the crank pulley beforehand, and paint the timing marks with some white-out.



## Intake side of motor

---

- PCV Inline Check valve UPGRADE by Rod XRFordiac

**Q:** So I'm blowing oil out my dipstick tube. I want to put in a new PCV valve and see if that fixes it, but I want to double-check the P/N I have. I've got E5ZZ-6A666-A as the correct number, but I want to make sure that's right because the last number I got from the P/N listing was wrong.

Thanks -- Harold

**A:** Use motorcraft part number EV-127A or the steel one that NAPA sells. It should not pass air in one direction when you blow thru it.

**A2:** I realize that some of you have been buying these valves from bone yards for about .50. For those of you who would prefer a new one, you can find them at NAPA for about 5.00. Just ask for part # 2-9411. It looks almost identical to the one I bought from Mazda only it is a lot less money. And I just installed one on my 89 XR and it seems to be doing the job.

---

- TPS, TB, ICS gasket source by Fritz Knapp

FYI, AutoZone: \$4.49

Sorensen, part no. 059534 96-3005

Fuel Injection Repair Kit

On the instructions, inside the box, Throttle Body Gasket Pack.

It includes a TPS gasket, a TB gasket and ICS gasket. There are three or four ICS gaskets that can be used, maybe a bit of trimming to remove excess gasket material. The kit includes gaskets for other applications.

---

- Troubleshooting the Vane Air Meter VAM by Terry Watson and Mike Shaw

Running way rich - VAF codes?

**Terry:** I'll run them again in the morning when I won't bug the neighbors, but it should be easy to check the VAF output voltage. I am thinking that possibly the door is binding? If the door was sticking open, the computer would think the engine is sucking a lot of air and add fuel. The car cleans up over about 3,000 rpm, but with the throttle closed and coasting, I am right in the middle of the AF LEDs, and any throttle jumps me rich. I don't know how the TPS plays into the fuel metering, but I could see how conflicting info to the computer could cause problems. Is my logic reasonable? Anyone have sticking VAF problems (it is an SVO unit).

**Mike:** I don't understand the 12 but the 41 does make sense because it is trying to make it rich because it thinks it is too lean. So it keeps trying and it is way too rich. Sounds like your O2 sensor is bad. Check the wiring to the eec-iv also. 26 & 76 You may have some dead spots on the VAM resistor plate and it doesn't think it is moving. Use an analog voltmeter on pins 2 and 5. The voltage should start at .5v and increase to 4.5v as you manually, slowly open the VAM door. (Key on). If this is good then it is a wiring, connector problem. You may want to check all the wiring into the eec by removing the connector and making sure all the pins are in and aren't backing out or corroded.

KOER Codes:

12 - RPM didn't reach range (i don't understand this one as I did the WOT)

26 - VAF sensor out of range

41 - EGO sensor lean (this seems strange as it is running real rich)

76 - Insufficient VAF change during WOT

**Terry Again:** Hi all. Thanks for the inputs from a number of people. When I checked the VAM output (engine off) it was 2.56 VDC, supposed to be .5 V or less. Looked in with a mirror, and the door was open a bunch. Pushed it closed and it was binding.

Bench tested it, and it has a flat spot, and is intermittently sticky. Have removed the bottom cover and cleaned things up, and it worked very smoothly, but the sticking comes back randomly. Time to pull the top cover.

I am pretty sure this is my only problem, as everything else seems to test out okay. Again, I can see how a large VAM signal when there should not be one could screw up your day. I can also understand why when it happened before that it mysteriously cleared itself up – the intermittent sticking.

---

- Generic K&N Cone Air Filter part no. RE-0930

- PCV and Dipstick Issues by Ed Lijewski

**Q:** What would cause a rough idle, lack of vacuum at idle, -10 to -7 psi instead of -10 to -20 psi, and air hissing from the dipstick? If I pull out the dipstick while the motor is running, it stalls unless I put it back in right away. I really hope this is something silly or stupid, like a bad PCV valve or something small I can't think of. Either that or its blown compression ring(s), and I didn't plan on rebuilding my motor for a while.

**A:** Your dipstick has a bad o-ring. Best fix (thanks to Dave Planakis) is to take the boot of an old spark plug wire, remove the wire (pull it out), cutoff about one-inch or so of the lower end of the plug boot, apply a small bit of light grease on the inside hole of the top end of the plug boot, mount the boot on the dipstick tube (press it on), and then insert the dipstick through the plug boot. Makes a great seal and resolves for many moons any issues with PCV vacuum leaking from the dipstick.

## Interior

---

- XR A-Pillar Differences by Dave Compton

If the holes in the metal pillar are not where the holes in the plastic pillar are, just put a nail thru the plastic pillar hole and make a new one in the metal by hitting the nail with a hammer a few times. Don't go nuts here, it isn't all that hard a metal. Save trying to do a cosmetically acceptable repair on the pillars you searched high and low for. If you're really anal about the exposed edges of the new hole, just put a sealer of your choice on the edges.

---

- Source for the correct Rear View Mirror Adhesive by Lih-Yen Hsieh

This has been covered a couple of times. The best solution seems to be 3M high-temp/high strength double sided mounting tape, available at Radio Shack for \$1.99 a pack of 4 strips which services exactly 8 mirror installations. Clean bonding surfaces, warm area to above 50°F, blah, blah.

The expandability of the tape's foam base and the high sheer strength provide a flexible coupling between the glass and the mirror base to expand and contract with very different coefficients, and the high temp. characteristics (200°F?) makes it excellent choice for this application. When applied properly it is nearly invisible. This stuff is originally designed for mounting circuit components such as relays in harsh environments, like engine compartments, without drilling holes in sheet metal.

Radio Shack "Hi-temp/Hi-strength SUPERMOUNT TAPE" (3M VHB)  
Cat. No. 64-2361 \$1.99/4-pack (enough for 8 mirrors)

---

- Door Panel Adhesive by Mick Taylor

**Q:** I have had absolutely no success gluing the skin back onto the door panels. Each time it eventually comes loose again! What works???

**A:** door panel glue - 3M 08090 super trim adhesive - spray can will do 13cars (ok maybe 3) there are instructions which have to followed to the T. - Mick (works like hot sh\*t to the proverbial blankie) avail most corner store auto parts outfits.

---

- Sagging Headliner Repair by Richard Curtis

**A:** Redoing the headliner is pretty easy. There are two basic ways: remove the headliner and take it to an upholstery shop to put the new one on the fiber board backing on OR do it all yourself. I paid \$75 to the shop.

While you're doing the headliner, take the time to PAINT the plastic trim. I chose a gray that matched the leather. Spray paint especially made for plastic is available from auto paint stores. Don't forget to paint the screw heads!! This is THE MOST GRATIFYING PROJECT I'VE DONE SO FAR. This is also the time to fix roof drains or put in a new roof antenna. How about a light bar?? REMOVING THE HEADLINER Removing the old headliner is pretty straightforward. Just remove everything (yes, even the interior side plastic panels... I think they're called sail panels?) and the rear-most panel also (you have to remove the rear shoulder belt hold-down bolts; the most aggravating thing of all, I think). The old headliner panel slides out through the hatch. A second person to help makes this entire process most helpful and expedient. If you have a moonroof, just remove the trim thing (u-shaped); it pries right off. The light console screws are easily accessed by opening the sunroof since they are on the top of the car. No need to remove any of the moonroof hardware except for the winding handle. A reversible power screwdriver with a Phillips bit makes quick work of all the removal stuff.

### INSTALLING NEW HEADLINER MATERIAL YOURSELF

I wouldn't recommend trying to salvage the old headliner. I tried that; it doesn't work and makes a real mess of everything. Especially since installing a completely new one is fairly cheap and looks incredibly better. I bought the material at an automotive trim shop. They sell the

headliner material by the yard and it comes in a variety of colors. It comes in two thicknesses also; I wound up with the thicker (I think it was 0.25 inch); the thinner (can't remember exactly but it was probably just 0.125 inch) would be better but it wasn't too important. My shop didn't have the thinner material in the color I wanted. I was able to match the old headliner color almost perfectly. I think enough material to replace my old one cost about \$20. The glue is much more expensive: \$14 a can and it takes just a little over one can. Don't scrimp on the glue and forget the 3M product (been there, done that). I used "Super Bond Trim Adhesive" by SOSMETAL Maintenance Products (for professionals). Sosmetal No. 211417; bought at the trim shop.

Strip off the old headliner material; mine came right off. I then used a stiff wire brush to clean off as much of the old glue as possible from the hardboard liner. The old glue is yellowish-orangeish and yucky. The more you get off the better although getting the old panel absolutely clean isn't imperative. The new headliner material is foam backed and the foam backing will disguise any old balled-up glue that you leave behind. Be sure to clean your hands REALLY well before handling the new material.

Then spray a good, thorough coat of glue on the panel. If I remember correctly, after the glue set up on the panel, I then laid some wax paper over the glue-covered panel and then carefully positioned the headliner material (you'll definitely need some help doing this part). Working from the center of the panel, first spray the material with a coat of glue and, after it sets up (only a few minutes), remove the wax paper a strip at a time and press the material into position on the panel, working from the center toward the sides and the ends, work out any bubbles, etc. Be advised that once the glued fabric meets the glued panel, it's stuck pretty much forever so caution would be a good thing.

Leave about an inch or two around the entire panel. After you've gotten the material attached to the panel, go back and trim off the excess with a sharp razor. I folded about a half-inch of material around to the backside of the panel to make a trim appearance (this is where the thinner headliner material would be easier to work with. If you have a moonroof, do the same thing here, trimming carefully and wrapping the excess.) After it was all done, I then used a brayer (a little roller thingie used in newspaper composing rooms and art departments) to roll down the material evenly over the entire panel to make sure it was firmly attached.

Most difficult part of the entire operation was reattaching the trim piece around the moonroof opening. I think the whole job took me about 3 hours; the next time, this would be about a 90-minute job.

Richard Curtis

-----



## Junkyard Strategies

---

- What parts to get off a T-bird? by Don Davis, Rob Eddy, and Michael Politis

**Q:** What parts to get off a T-bird? A friend is about to junk his 2.3 Turbo intercooled 5-speed T-bird, it has multiple problems and most likely a cracked head. What parts should I be taking off the car before it goes away, to use on my Merkur XR4ti? Don Davis

**A:** The car is worth a small fortune as parts. Good IHI turbo=\$125. IC=\$50, or so. LA3 computer \$40-\$75. Header panel (where the headlights mount)-I sold one that was cracked on Ebay for over \$100. (I started the bidding at \$10).WC T5 tranny=\$125-\$300. Front disc brakes=\$75-\$150 (Great for Mustang guy's who are looking for better brakes for their pony.) Sway bars(?) (Another M'tang upgrade.) Rear disc brakes-bolt onto your XR w/ the proper caliper mounts.) 8.8" rearend w/ 3.55 Traction Lock unit=\$150-\$300 (Another M'tang upgrade.) Uncut EEC-IV wire harness=\$75-\$100 Hood=\$75-\$100. 16" wheels=\$200 or so. My advice would be to send the car to the JY as a bare shell, list the stuff on Ebay (that you can't use on your XR) and use the \$\$\$ made to buy some other good parts for your XR. Am I forgetting anything? Good luck! Rob

**A:** Don, It depends how much work you want to do. I would recommend taking the: T-5 tranny LA3 Computer Intercooler (If you don't have one) ACT sensor off the intake manifold plus ACT Connector, Larger Air Meter, It isn't a bad idea to grab the brown top injectors as well. Michael Politis

## Merkur Miscellany

---

- Source for the **XR Torch-key light battery** by Bill Stobbe  
I was in the Ace Hardware store battery dept, and found this battery to light the 1.5 volt bulb in our factory keys.

Lucky Line "Key Light Battery"  
1.5V Replacement Battery  
for 90801 Key Light

Ace PN= 5067103

They can order them if your local Ace store is not carrying this in stock. They sell a key fob with a small light. This battery is a direct fit, no modifications needed.

- Volkswagen Part number for Merkur Key Fob by Warren Shukis  
A listing last month gave the Volkswagon part numbers for a battery and bulb to fit a Scorpio key fob flashlight. The listing stated it wasn't known if these items would also fit a Merkur Key Fob.

The answer is yes! I recently replaced the battery and bulb in my '86 XR key. Here is the info:

N-902-624-01 Battery \$2.37  
N-903-145-01 Bulb \$2.09

---

- XR Production Quantities by model Year by Wheelspin  
1985 1986 1987 1988 1989 Total  
12,400 13,599 7,342 6,283 2,870 42,464
- 

- I Locked my keys in my Scorpio by Ryan Mattson  
**Q:** In my zombie like state on my way in to work this morning I left my keys in the car. Does anyone know what pins on which relay I need to short to open the door locks?  
**A:** The two bigger connector slots are the power to the hatch... the relay is closest to the passenger side, third row from the driver counting from the back of the car towards the front). It's one of the small brown relays.

o o o o o  
o o o o o  
x o o o o  
o o o o o  
o o o o o

(fuses)  
(fuses)  
[front of car]  
<pass side

---

- Taurus/Tempo door chime Upgrade by Larry Biles and Jon Lofquist
- Larry Biles Writes:

Your old "buzzer" is mounted on a metal plate (along with the turbo over-boost buzzer; the smaller of the two), under the dash, on the left-hand side of the glove box. First, remove the 3 round-headed metal push clips securing the front of the thick felt sound deadening panel to the under side of the dash (I was able to pull the round-headed clips out with just my fingers; or, they can be easily pried out with a screw driver). When the felt panel drops down, shine a flash light up there (again, left hand side of glove box), and you will easily see the black plastic rectangular buzzer. To remove the buzzer from the mounting panel, simply grasp it with your hand and twist it 1/4 turn to the right. It is now free from the mounting plate (no attaching screws--just a square peg in a square hole deal), and you can now pull it down to unclip the wiring harness connector from it. Take the new chime and simply plug it back into the connector (it's an exact match/fit). The chime was mounted to the Taurus' plate with 2 screws, so you can't reattach it to the XR's plate in the same manner. No biggy, though; I just pushed it back up in the space and secured it with a

tie-wrap. Heck, you probably don't even have to attach it to any thing, because once you clip the felt panel back into place, it can't fall out!! That's it, your done! Shouldn't take but 10 minutes, at the most, to make the change.

- John Lofquist adds

On the Taurus, its under the dash just to the right of the steering column. Make sure it's the one with the same connector as the XR. You can also find this in some Tempos. Somewhere at home I have the exact part numbers and years where you can find them.

(left the buzzing behind for a chime years ago - it's so much nicer to start your day that way) :-)

The only minor "negative" things that I noticed about the swap-out were that, while the electrical connector is identical to the XR's (truly plug-and-play), the Taurus chime is just slightly larger than the XR's buzzer, and it has a different mounting set-up (I just cable-tied mine to the XR's mounting plate; no biggy!). Also, I wish that the chime was just a "smidge" louder, since we do have to mount it under the dash way over on the passenger side (they are mounted on the driver's side in the Taurus, so it is a little easier to hear). But again, no biggy! I really like the two distinctly different tones you get for the "key-still-in-ignition" warning, and the "you-left-your-lights-on-stupid" alert. And, don't laugh, but the chime's more pleasant "ding" sound (vs.. the buzzer's "gets-on-your-nerves-bzzzzzzz" racket), seems to take 10 years off the age of the XR, psychologically speaking of course. Go figure!

- Taurus/Tempo door chime sources by Brad Anesi

As mentioned previously, the chime from a Taurus/Sable is to the right of the steering column, but it's pretty deeply buried in there. Unless the dash has already been pulled apart, it's probably best to move on to another car where someone has already done most of the work for you. Alternatively, you can get one out of a Tempo/Topaz much easier. They are mounted behind the knee bolster and can be removed in 5 minutes without getting bloody knuckles.

If you go for the Taurus, you need to get the chime from a pre '87 car. The later cars used a different connector than the XR, so pull the one from your car first so you know what to look for. Note that the one from the Taurus actually is preferable to the Tempo, as it is a solid state device and has proven more reliable.

=====

From the January 1989 issue of Motor Trend, there is a mention of the demise of the XR4ti.

-----

**Detroit Report**

**LAST YEAR FOR THE MERKUR XR4TI**

The Merkur XR4Ti will be discontinued at the conclusion of the '89 model year, Ford sources said.

Some owners and Lincoln-Mercury dealers received letters explaining Ford's decision to cancel the turbocharged sporty coupe. The letters specified that the car was being cancelled to save the costs of reengineering it to comply with the 1990 passenger restraint rules.

Buyers never warmed up to the XR4Ti, a perennial slow-seller and the first product fired from the new Merkur product cannon. Ford planners admit that they erred badly in front-loading early orders with manual transmissions. The market, as it turned out, really wanted automatics. XR4Ti marketing never seemed to establish the car's niche. Confused potential buyers could never quite decide if the attractive Karmann-built coupe was a luxury car with sporting overtones, or the reverse.

Ford's notable successes with the car were with SCCA Trans-Am racing, where it won the Manufacturer Championships in 1986 and 1987. The car also won the '88 IMSA GTO crown for manufacturers. Speculators believe the motorsports gap will be filled by the sleek silhouette of the

new Mercury Cougar, whose supercharged XR7 street variant authoritatively supports the high-performance image.

---

George Nielsen  
1984 Sierra XR4i

---

- **Bootleg Copy of Helms Service manual for XR4Ti.**

"Pat H {S.A.M.A}" [xrclub@cadvision.com](mailto:xrclub@cadvision.com)

Workshop Manual

\$69.50 plus \$14.00 shipping and boxing and handling..

comes shrink wrapped...1620 pages and comes double sided...

off-list at [xrclub@cadvision.com](mailto:xrclub@cadvision.com) I accept paypal too..

---

- **A Story you might enjoy.**

I have worked for the Ford Motor Co. for 28 years. In 1984 about 500 of us were told to attend a meeting at a large movie complex near our office. Once in place we were told of a new line of cars that was to be imported from Germany. On the movie screen was flashed a picture of a horse then a "+" and then a can of Coors beer. We were told the new cars were pronounced MareCoor. I can remember turning to the person next to me and saying "This product is doomed"...

---

- **XR Light On Warning buzzer Upgrade** by Jon Lofquist

As promised, I've finally gotten around to writing up how to add the wiring to the XR so that the buzzer will go off when you leave your lights on.

Background:

On 85-88 XR's the buzzer will sound when the ignition is off, either door is open, and the key is in the ignition. There is no warning for leaving your lights on. On 88.5-89 XR's the buzzer will sound when the ignition is off, either your key is in the ignition or your lights are on, and the driver's door is open.

This mod is to add the lights-on feature to the earlier XR's.

What you need:

- 4ft piece of 18 gauge wire
- One general purpose diode. 1N4002 through 1N4007 would be a good choice. Available at Radio Shack.

Description:

- Solder the diode end WITHOUT the band to one end of the wire. Connect the end WITH the band to the solid red wire going to the buzzer. Connect it by either soldering, or solder on another short piece of wire and use a wire connector. Insulate everything with electrical tape. Make sure you're NOT connecting to the red wire with a blue stripe.

- Connect the other end of the wire to the solid gray wire at the panel dimmer switch to the left of the steering column. Make sure you're NOT connecting to the gray wire with a green stripe.

For you electrical folks, what we're doing is now also powering the buzzer with the panel light circuit. The diode is to prevent backflow from the key-in circuit from lighting the panel lights.

Result:

The buzzer will now also sound if parking lights or headlights are on and either door is open.

Now better yet, while you're in there replace that blasted buzzer with a nice chime from a mid-80's Taurus. A direct plug in. This will also change the seat belt warning to a chime. It will not affect the overboost buzzer.

Also - want to be able to use your fog lights with just the parking lights on? Cut the yellow wire on the back of the fog light switch. Connect the stub left attached to the switch to that same gray wire at the light dimmer. Don't forget to insulate the other end of the yellow wire to prevent a short.

- Additional comment by Jim Gosses

Thanks for the info, just completed the headlight warning - works great - Hopefully no more "lights on" dead batteries! I was able to do the job without taking any of the lower dash apart, the dimmer switch will pry out of the front of the dash and you can reach the buzzer from below. The only thing that I removed was the cassette holder to aid with fishing the wire through.

- Dealing with Insurance Companies after an Accident by Keith

Let me teach you a phrase I learned when dealing with insurance companies:

That is not acceptable.

They will talk crap, try to bully you. Stick to your guns. Key words: That car is MY PROPERTY. You can actually demand, and pay a wrecker, to deliver the car into your custody. You may also have to pay the initial wrecker and storage charges, but if you want the car, that's the way to go. I know it I ever get in an accident and am forced to tow my vehicle, it's coming HOME, and just for that reason. Once it's in your possession, you're not as bent over.

Call that idiot, tell them you are going to contact 3 salvage yards, average the offers, and THAT is what you are going to pay, or you are going to small claims court with it. Or better yet, mention FRAUD and ATTORNEY in the same sentence, then make your offer.

The reason we get run over by insurance companies is we don't know our rights, and are less apt to fight. There is no law that states insurance companies have to be fair. Nut up early, and usually things will go smoother because they really don't want the headaches. They'll hump you in a split second if you bend over, but will think twice if you don't. Usually.

## Miscellaneous

---

- Key Broken off in Ignition by Jim Holton and Will Hunt

**Q:** This is something new.... I broke my key off in the ignition when starting my car. Just a nub left on the key ring with a very hidden end in the ignition. I had to pull the battery cable to stop it. This should be fun

**A:** The ignition switch and the ignition switch lock are separate parts of single assembly and can be R&R'ed separately. The switch works fine without a key. Disassemble the steering column cover and disconnect the lock cylinder from the ignition switch assembly. Then you can work the car with just the switch (a vise grip may be required, I can't remember). The electrical harness for the ignition switch assembly may have to be unplugged and removed to be able to neatly separate the lock and the ignition switch. They kinda just unplug from each other. Fear not, you'll see it all when you get down in there. Not as bad as it sounds, at all. You might want to just let the switch and harness hang for easier access and operation until you've gotten the lock un-jammed on the bench. Then: The car will be shutting off and starting as usual but the ignition cannot be locked any longer. Use your spare key to lock the doors for security. Work on the lock cylinder on the bench or take it to a locksmith. Or..... take this opportunity for installation of a complete new lockset.

---

- VIN decoder by MerkurGarage

Look here: <http://resources.merkurgarage.com/MRK/MerkurCodes.html>

---

- XR Differences between the years by Richard Curtis and Chris Anglin

### **Richard Curtis:**

mechanically, there is no difference between 85-89 XRs.

Radiators are different in late-model 88s and all 89s. The biggest differences are:

- 85s did not have center mounted brake light on the wing.
- the trans tunnel got slightly bigger during the 87 model year.
- leather interiors and dashes were less prone to cracking as you get closer to 89 model year, but I've seen even some of the newest models with cracks, tears, etc.
- 85s and 86s had 14" phone-dial style wheels.
- 87s and early model 88s had pie-spoke wheels, 15"
- late-model 88s and all 89s had BBS basket-weave style wheels
- late-model 88s and 89s had Raven black leather interiors.
- rare are the late models with tan interiors, either cloth or leather
- late-model 88s and all 89s had coolant overflow tank on driver's side inner fender
- all cruise-control was available on all XRs, it is most prevalent on 88s and 89s.
- Valve covers are different in later models (they have a "hump" in the front with different baffling internally)
- early-models have a finned turbo-to-throttle-body tube. Later models are smooth.
- early models have 85 mph speedometers. I think this changed to 150 mph in late-model 88s and all 89s.
- 88s and 89s have a single rear wing. the hatch has larger glass also, although you can install an early-model biwing hatch in 88s and 89s. The rear glass is not the same.
- some late 87s, all 88s and 89s use the rear window defroster grid as the radio antenna.

### **Chris Anglin adds:**

Most changes were minor, but some are worth noting. The brake pedal (and probably gas pedal) was (were) changed to accommodate the different floor pan of the later cars. There is a third brake light in the spoiler of the 87 (started in 86), the wheels are 15" vs. 14" (for 86 and 87). The brake booster system went from a single diaphragm to a dual diaphragm in 86 (I think). The power steering rack was changed after 85 resulting in less turns lock-to-lock.

There were a ton of small changes too, such as... The cloth pattern was changed after 85, there



is likely no "low oil" indicator light in the center warning lights around the clock, the dash no longer had the center speaker grille leftover from the base European models (no biggie).

**Bill Stobbe** adds:

- Late '87 cars got the famous problem prone "anti-slosh" board.
- Late '87 & up car radios gained an additional amp below the radio lost the joystick to control fade/balance lost the cassette holder below radio to allow room for the amp
- Late '87 and up cars had a dipstick with no level sensor and no dash light for low oil
- Dash design changed in '88? with different windshield pillars
- Late '87 and up cars all had an exhaust manifold re-design to strengthen that place that always cracks ( #3 cylinder? )
- Oh, and picky picky, the merkur XR4ti lettering and badging changed in late '87 and up cars. No Oval on the newer ones, just the word MERKUR on rt, with XR4TI on left.

**Steven A. DuChene** adds:

Also at some point between the '85 and '87 cars a change was made to the way the window mechanism works because the '85 cars left about 3/16 to 1/4 inch of window sticking out of the door when it was fully retracted. The '87 I have retracts the window completely into the door.

Also the '85 door locks required you to hold the door handle up while closing it or it would unlock the doors again. On my '87 I just lock the doors and close the door. I don't have to hold the door handle up as I close it.

**Kenny Heck** adds:

Of the models I've seen, everything concurs with what Richard has stated with the exception that my mid-July build '88 (very late '88) automatic has the same coolant system as all the earlier automatic models.

Additionally, early '85 (sometime before 04/85, definitely 01/85 and before) had slightly different front calipers. They also had a slightly different wiring harness and interior door lock knobs that were rounded rather than triangular. Additionally, the 5-speed rubber mount was rectangular rather than round. Early '85 A/C componentry was different at the receiver/drier and the high pressure line attached to it. Other than the wiring, all of these things are easily changed to later-style components with complete assembly replacement. Early style calipers are apparently still readily available though (10mm holes in them vs. the later 1.5mm holes to hold the anti-rattle clips).

Mid '86-on (02/86) received what I personally consider to be a better block with the ability to use readily available rubber oil pan gaskets. Very late '86-up received a better heater core. Once again, these items are easily updated on '85s and early '86s by simple replacement.

At some point there was apparently a front hub design change along with an updated 5-sp though I'm unsure of when these changes occurred. Additionally, I've seen several small internal updates on the C-3's that I've torn apart ranging from '86 through '89 (these changes were also partway through model years). As before, parts are interchangeable as whole assemblies between the model years. My '85s have the rear washer shooting up from the wiper whereas my '86 and all later models have them shooting down from the top of the rear window. On the subject of wipers, the front one originally had a "wing" on the driver's side that was dropped at some point. Probably some other things I'm forgetting, but I'm sure others will add to the list even more.

Oh yeah, one last good one that will catch you off guard when you least suspect: the screws that hold the exterior door handles on are different sized at some point. Forget which way they are and don't know when they changed, but if I remember correctly, the early handles are held on by

a larger fine-threaded bolt-type screw whereas the later ones are held on by a smaller self-tapping screw. Tend to remember the corresponding holes in the door to be of different sizes too, which can create a slight dilemma if you are using the larger screwed handle on the one with smaller holes, especially if you don't want to blemish the metal of the door.

**Kevin Richardson** adds:

Here are a few minor differences I've noticed:

Earlier shift knobs have a plastic plate with the numbers on it. My 86 (and later ones that I've seen) have engraved numbers. The plate seemed to be a source of vibration on my friend's 85.

Early 85s will not have the cruise wiring the steering column switch.

Size of the hatch glass is larger on single-spoiler cars.

There is a subtle difference on the wiper switch. The intermittent will either have broken lines on below the windshield picture, or will have a broken wiper-line on the picture. (Hard to explain) I'm not sure if this is a difference between years, or just random.

I saw a wrecked XR (early 85) the other day with manual windows and a dark blue, plaid-patterned interior.

**Richard Thompson** adds:

88 and 89 have rubber surrounds on the small fixed quarter panel windows. They are generally destroyed when you try to remove them.

=====

Scorpio Differences between the 1988 and 1989 years by Various

David Malarky: Early 88s had the Chubb key had different seats only the bottom half was power. They also had heat in the back seat. Tail lights were different and the Lights that tell you if you got a headlight or tail light out was different. Now if you got a later built 88 it will have a Tibbie type key and will be the same as the 89 Full power seats no rear heat and the newer style lighting cluster.

**Jake Delgado** adds: The cars are pretty much identical depending on when the '88 was manufactured. My '88 was 8/88. The '89 has different vacuum hose routing on the passenger side which makes changing the oil filter a little more challenging. The '89 has a different AC hose routing in the engine

compartment. The '89 has gas struts for the hood rather than a prop rod. The '89 has an additional switch position on the light switch for parking (a European thing). The '89 has a belly pan under the engine compartment. The '89 has a single-speed electric fan in front of the AC condenser that has different blades for quieter operation. The '88 has a two speed fan and a different coolant temperature sensor in the radiator. Some '88's don't have a check engine light which is a hassle in CA, since the smog monkeys expect to see one in every '88 and will try to fail the car if it is not there. The early '88s had more adjustments on the front seats and the seats were not all power. My '88 has all power seats, though I don't have the optional seat heaters. I personally prefer working on the '88, especially around the engine.

**Jon** adds: Washing fluid container is different between 88 and 89, overflow coolant res. is different, hood on the 89 is held by compressed gas shocks whereas the 88 uses a prop rod. Early 88s also had a little vent for rear passengers.

**Tom:** While installing an '88 engine in my '89 there was only one difference noted. The donor engine was from an early '88 and the pads on the block where the air conditioning compressor bracket mounted were different. The earlier block used three pads and the aft one was raised about 5/8 inch. On the later engine all were in a single plane. Made for one less machining step. The cast aluminum bracket from the '89 would not align on the older block but a thick aluminum spacer and a longer mounting bolt handled the problem. The wiring harness for the injectors is also different at the quick disconnect plug but this is only a matter of using the chassis specific harness.

**Bo:** Early '88's windshield wiper arm rotated from beneath cowl of hood, often rubbing the wiper arm, allowing for rust conditions in that area of the hood. Not a real problem if corrected early.

- 
- Parts number decoding by



### Guide to Decoding Ford Part Numbers

Often friends will call me trying to determine Ford parts they can use or substitute. In SCCA Solo and Club Racing the rules often allow updating/backdating parts. In other words use a older or newer part from that product line of car. An example is my 1985 Mustang in American Sedan, generally I can use any bolt on component from 1979 through 1993 Capri or Mustang. The front brake system currently on the car is from a 1987 Mustang. The original 1985 brake system utilized an 10" front rotor while the 1987 system is 11" increasing the swept surface area of the brakes. The entire front suspension had to be replaced, lower front control arms, spindles, rotor, strut, calipers, brake hoses. Knowing how the part number system works helped considerably.

Ford part numbers are divided into two main categories **Engineering** and **Service**.

The engineers will design a part and assign it an Engineering part number, which is an alphanumeric reference code. When the part is redesigned the change needs to be noted so the Engineering part number is changed. When the part is released for Service it is assigned a Service part number. This allows Ford Parts and Service to track changes affecting interchangeability by modifying the Ford Service part number. The Service part number will not change with the Engineering part number unless the change affects interchangeability. Due to this the part numbers on the part are generally Engineering numbers while the Service part number will be on the box. There are some exceptions, such as a whole grouping of parts or a kit. Engineering and Service numbers decode the same way. The difference being the fourth character of the prefix. Part numbers consist of a prefix, a basic part number, and a suffix. An example would be F4ZZ (prefix), 6E086 (basic part number), -A (suffix). The first character of the prefix indicates the decade of design, starting with "A" for the 1940's, B for the 1950's, C for the 1960's. The second character of the indicates the year within the decade, "C5" would be 1965, "F4" would be 1994. The third character of the prefix indicates the product part the part was originally designed for, with few exceptions. Note that "outside sales (code F), "Motorcraft Brand" (code P), or imported parts from Ford of Europe (code R) are identified with their product line code in the third position. The fourth character indicates the part source, whether it is product engineering office or service part. The part number F4ZZ-6E086-A would equate to F4 = 1994, the third character Z = Mustang, the fourth character Z = Ford Parts and Services. The next group of numbers describe the part. I use these numbers at swap meets or salvage yard to match to existing numbers I have. I know if the basic number is the same it should be compatible if the suffix number on the part you are comparing is a later alpha character than the existing one. Early suffix designations generally begin with "A" and increment through the alphabet as design changes are made that affect interchangeability. If the suffix on the part I was looking to replace (my existing part) was an "A" I could use parts with have a "B" suffix. If the part I was looking to replace (my existing part) had a "B" suffix, a part with the "A" suffix would probably have a compatibility issue. Parts that have later suffix codes are the ones to get.

## Prefix Decoding

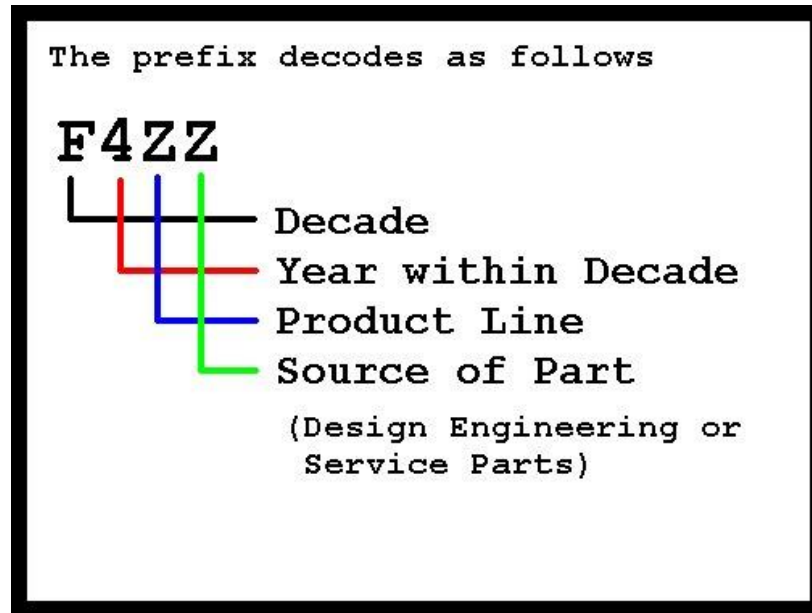

## Product line codes.

Third Digit	Product Line
	Use the third character of the part number with this chart.
A	Ford, 1958-later
B	Bronco, 1970-73; Maverick 1975-77; Fairmont 1978-83
C	Remanufactured parts 1966-75
D	Falcon 1960-69; Maverick 1970-74; Granada 1975-82; LTD 1983-later
E	Truck (cab over engine) 1970-73; Pinto 1976-80; Escort 1981-later

F	Outside sales1962-later
G	Comet 1961-67; Montego1968-76; EXP 1982-later
H	Heavy truck 1966-82; Medium and heavy truck 1983-later
I	Not Used
J	Industrial Engines
K	Edsel 1958-60; Cab trucks 1970-73; Comet 1975-77; Zephyr 1978-83; Marquis 1983-later
L	Lincoln 1958-60; Mark 1961-later
M	Mercury 1958-later
N	Tractor 1958-later
O	Fairlane 1962-68; Torino 1969-76; LTD II 1977-79; LN7 1982-83
P	Motorcraft (or Autolite) 1962-later
Q	Not Used
R	Rotunda Brand1962-69; vehicles imported from Ford of Europe1970-later
S	Thunderbird 1958-later
T	All truck 1958-65; light and medium truck including Bronco 1974-82; light truck and Bronco I 1983-later
U	Econoline 1961-later
V	Lincoln Continental 1961-81;
W	Cougar 1966-72; Bobcat 1975-80; Lynx 1981-later
X	Trucks (short highway) 1970-73
Y	Meteor (Canadian) 1962-73; Bobcat 1975-80; Lynx 1981-later
Z	Mustang 1964-73; Mustang II 1974-78; Mustang 1979-later
1	Not Used
2	Pinto 1971-75



3	Tempo 1984-later
4	Comet 1971-74; Monarch 1975-80; Cougar 1981-82; Marquis 1983-later
5	Recreational vehicles 1974-75; Continental 1982-later
6	Pantera 1971-75; Ranger and Bronco II 1983-later
7	Courier truck 1971-75; Ranger and Bronco II 1983-later
8	Capri (US designed parts) 1972-75
9	Turbine engine parts 1970-75

## Source codes

	Source codes
Fourth digit	Use the fourth character of the part number with this chart.
A	Light truck Engineering
B	Body and electrical product Engineering
C	Chassis Engineering ; Powertrain and Chassis product Engineering
D	Overseas product Engineering
E	Engine Engineering; Powertrain and Chassis product Engineering
F	Electrical and Electronics Division; Product Engineering office
G	Not Used
H	Climate Control Division; Product Engineering office
I	Not Used

J	Ford Parts and Service Division; Parts and Service Engineering office
K	Not Used
L	Ford Parts and Service Division; Industrial Engine Operations
M	Performance Operations; SVO Service Parts
N	Ford Tractor Operations; Product Engineering Office; Diversified Products Operations
O	Not Used
P	Transmission and Axle Engineering; Powertrain and Chassis Product Engineering (Automatic Transmissions)
Q	Not Used
R	Transmission and Axle Engineering; Powertrain and Chassis Product Engineering (Manual Transmissions)
S	Light and Heavy Truck Engineering; Truck Special Ordering Department
T	Heavy Truck Engineering
U	Special Vehicles Operations
V	Vehicle Special Ordering and Engineering Section
W	Transmission and Axle Engineering; Powertrain and Chassis Product Engineering (axle)
X	Emissions, Economy and Special Vehicle Engineering
Y	Ford Parts and Service Division; Parts Engineering Office (Lincoln Mercury Division Service Parts)
Z	Ford Parts and Service Division; Parts Engineering Office (Ford Division Service

Parts)

## Decoding Dates

Date codes are sometimes included on parts. The first digit is the year. To determine the decade, refer to the part number's prefix. The second digit is the month. Note that the character "I" is not used. Refer to the chart below. The third digit is the day of the month.

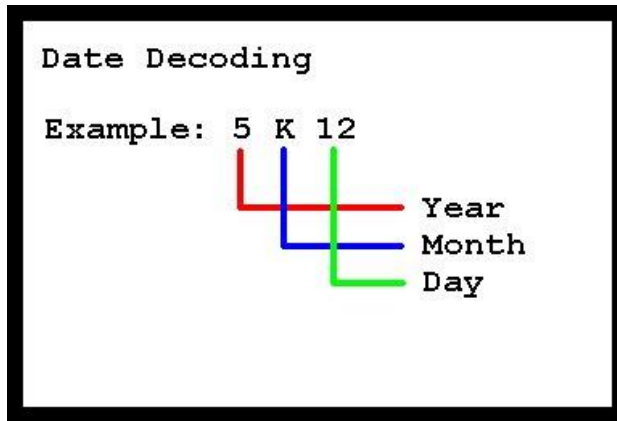

Second Digit	Month
A	January
B	February
C	March
D	April
E	May
F	June
G	July
H	August
I	Not Used
J	September
K	October
L	November
M	December

---

Copyright 1998 Howard Duffy.  
Last revised: July 98

## Parts Sources

---

As far as for your performance needs contact B.A.T. (British American Transfer) in Sarasota, FL. They have excellent parts and advice and have reasonable prices. They can point you in the direction you should go to get the performance you are looking for in the different racing fields.

BAT, Inc.  
7630 Matoaka Rd.  
Sarasota, FL 34243  
(941) 355-0005  
Fax (941) 355-4683  
<http://www.batinc.net/main.htm>

---

For specialty parts you just can't find anywhere else. You should use Russ Harness and Rapido. Rapido is more expensive, but Russ has stuff you just can't get anywhere else. Russ has an excellent knowledge of the history of the Merkurs and really needs all the support he can get. He is one of the few that is dedicated to preserving the Merkurs as they are. When Ford obsoletes an item he has the item reproduced and offers it to the Merkur community. When I can afford to do so I support him all I can. On Friday they are only there until 12:00 Noon Pacific time. Their Hours are M-F 8:00-5:00 Pacific Time

Rapido Group  
80093 Dodson Road  
Tygh Valley, Oregon 97063  
(541) 544 - 3333 [Office]  
(541) 544 - 3100 [Fax]

---

Distributor cap, rotor button, radiator cap and T.P.S. sensors should always be purchased from your local Ford store.

Spark plugs should be Autolite 764's or NGK's. If the car has Bosch plugs, let that be the first item you replace. Bosch plugs do not perform or last as they should in our vehicles. The Autolites last the longest are the cheapest and perform the best. I'm even referring to the high end Bosch silvers at \$18 a plug. DON'T use them! Your performance and fuel mileage will suffer. As far as spark plug wires you should use Magnecor or MSD. Magnecor are by far the best and no other wire comes close. MSD are acceptable and should do just fine and are not as expensive. B.A.T., Rapido Group and Modern Performance are good places to get these wires. Nick at Modern Performance is heavy into Autocrossing XR's and is an excellent source of information and high performance parts and accessories. Nick is a real mover and shaker in the Merkur community in the Eastern US.

---

Nick Mannarino, Owner  
72 Oceanport Avenue  
West Long Branch, NJ 07764  
Phone: 732-222-3679  
Email: [mp23cc@aol.com](mailto:mp23cc@aol.com)  
<http://www.modernperformanceinc.com/merkurproducts.html>

For your extreme performance needs there is Esslinger Engineering. If you want to be on top you'll get to know them very well.

Esslinger Engineering  
1432 Potrero Ave  
S. El Monte, CA 91733  
626-444-4919

<http://www.esslingerracing.com/>

Last but not least for all of your cam needs (the one's Esslinger or Modern Performance don't meet) there's Web Racing Cams. Web is owned by Steve Story and Laurie Dunlap. They are the industry leader in custom racing camshafts! They can do ANYTHING! They now retain Brian Axup former long time developer for Esslinger Engineering. As far as the cam and valvetrain setup for the Ford 2300... there's no one who knows the stuff better.

Web Cam Inc.  
1815 Massachusetts Avenue  
Riverside, CA 92507 USA  
Phone: 909.369.5144  
Fax: 909.369.7266  
<http://www.webcamshafts.com>

Between B.A.T., Esslinger Engineering, Modern Performance, Rapido Group, Web Cams and your local Ford dealer you should have no trouble getting your Merkur transformed into an extreme racing beast, if you so desire. The car out handles and out performs practically every other car that's ever been placed on the streets, when setup properly. The car is made to last and as long as proper maintenance is done will be around for a very long time.

Lastly, I've got to mention my List at least to spark your interest. If you so desire there is a conversion that is possible that is cheaper and better than the Esslinger ARCA head and is very comparable to the Esslinger Midget head. You must be mechanically inclined and have very good contacts and resources to accomplish the project. According to recent bench findings the head does out flow the Esslinger head. Which only backed up the claim I made nearly 3 years ago that Mark and I knew it did out flow the ARCA head from our measurements and calculations. Web Cams can do custom cams if you so desire after completing the project. They've already done some!

<http://autos.groups.yahoo.com/group/2300-16V/>

Take care Jeff and I hope all goes well with your project. You should find that you'll get many years of enjoyment out of it.

=====

Disclamer and atonements: I know I've left many, many people out of this list of suppliers, producers and groups. It's not my intention to do so. There are many out there and I've used quite a few of them and only listed a few here. There are many that are not mentioned here. I'm sorry and hopefully have not caused any hard feelings. That's not my intention. Just trying to steer a "newbie" into some resources to get his vehicle fixed and brought up to racing speed.

Later,

=====  
• An Open Mind Associates, INC./OPMD  
<http://www.opmd.com>  
Phil Dorsey, President  
18 Greenwood Ave  
Madison, NJ 07940-2105  
phil@opmd.com  
phone (973) 514-1306  
Fax (973) 514-1991  
=====

• **Lou Futz Ford –Internet Discounted Ford Parts** by Jerry Chandler

• 800-533-2175 St. Louis, Missouri

Lou Fusz Ford is a dealership just like ones that are located near you. Their parts desk is open for primary business during normal 'weekday' hours, Central Time.

The main difference between them and other FLM dealerships is that the parts manager, Mark Warner, brought a very successful concept to his management: cater to FLM car groups

and give them a discount from OEM prices. This has been very successful for Lou Fusz Ford because they are selling parts in volume beyond what your local dealership does. Lou Fusz is very different from your local dealer in this respect. When you go to most any FLM parts counter, where their parts guys work is just that: a counter, with parts computer. However, because of Mark's management, when you call Lou Fusz, you are not calling to a guy standing at a counter. Your call is received by one of their several parts guys located in a special parts computer room with at least four cubicles, where Mark and his guys work from desks.

Many, if not most, FLM parts 'counters' are not open on Saturday at all. Lou Fusz is open part of Saturday because they want to accommodate the large number of FLM club guys like us. Without asking, I do not know if they are only staffed by one person on Saturday, but I do know that they ALL rotate so that everyone, including Mark has to eventually work Saturday. If you have difficulty getting thru on Saturday, it is probably because of the very reason you are calling on Saturday... you are off from work just like a lot of other car geeks looking for parts and they are all calling. We need to find out their Saturday hours.

I suggest taking advantage of time zone differences, if possible, and call during Mon - Fri. They are there from about 8 - 4:30 Central. In the meantime, I will contact Mark and get their hours and best times to call.

For all the new Merkur owners on the list: Lou Fusz Ford provides a 15% - 25% discount on OEM Ford parts. Lou Fusz has a special parts dept. that caters to FLM car clubs for this discount. When you call, simply identify yourself as a part of "the Merkur internet group". They don't care about IMON, MCA, SLAMON, NOVAMOG, or WhateverMON. They have been a recognized sponsor to our original Roland Zuk IMON Merkur gatherings at Carlisle. They have provided HUNDREDS of \$\$\$ of prizes at several Carlisle events.

Call them for sourcing help and discounts at: 800-533-2175 I hope this helps



## Safety Issues

---

- What to do with an engine fire by Dave Compton 'Richard Klein'

That brings to mind a question: I finally got around to buying a fire extinguisher for my XR. I've since heard that, if you've got a fire under the hood, you should spray the extinguisher through the grille, because if you open the hood you'll feed lots of oxygen to the fire and it can backdraft on you. How do you handle that on a stock XR that has virtually no grille opening and a radiator and A/C condenser between you and a fire?

**David Compton replies:**

Good point. Having lifted the hood on a pretty good fire in progress, I can tell you,

DON'T lift the hood!

When you pop the hood release there is enough of a gap to shoot the extinguisher into. After a 2 second blast, you should be able to lift the hood and shoot any remaining flames. If it seems like a gas fire, use your knoggin. If it's an oil fire, you should be alright lifting the hood, after the first blast.

Cover your mouth and squint your eyes when discharging the extinguisher. The powder WILL come back at you, and it tastes like sh\*t. :)

Once you've discharged a fire extinguisher, use it all. It's useless once it's been fired.

---

- Fire Extinguisher Types by J.R.

**Q:** The problem with the chemical extinguishers, is you'll do just as much damage fighting the fire as just letting your car burn to the ground...

**A:** Respectfully, I have to disagree. While the mess left behind once a 'chemical' (mostly sodium bicarbonate) extinguisher has done its job can be a real chore to clean up, at least the effort can usually be successful, even if you decide to sell off 'parts!' Contrast that to the unrealistically low values assigned to our Merkurs (and many other 'specialty' vehicles) by most insurance companies, and I think "... just letting your car burn to the ground" comes in a distant choice. You probably wouldn't believe how many people make that choice at a vehicle fire scene, only to regret it later.

To use your 'A-B-C' fire extinguisher quickly & effectively means you can usually put out the fire with a minimum of residual damage & restoration effort required. Suggestions:

- 1)** Especially for extinguishers carried in vehicles, bump the container's bottom against the ground twice quickly before you attempt to use the extinguisher. This will break up the settled & caked chemical inside so that it will be ejected as a powder with the gas propellant.
  - 2)** Sweep across the base (origin) of the flames in short bursts, rather than just pointing & emptying the extinguisher. You may be surprised how little chemical it actually requires to put out the fire, and therefore, how little work the cleanup takes.
  - 3)** Maybe this should really be step 1), but keeping your interior/exterior/engine compartment clean/leather treated/carpet Scotch-Guarded/ grease-free/etc. equates to easier post-crisis restoration and in some cases, less material to catch fire.
- 

- Jump Starting a Car by Lih-Yen

That asked, I've always jumped in the similar sequence:

1. Red on dead battery positive,
2. The other red to rescue battery positive,
3. Black to rescue battery negative, and lastly, here's the difference:
4. For `_safety_`, the last connection is made at any suitable engine ground, away from battery. (Because with a fast charge such as jumping the battery generates significant amount of hydrogen, which can be ignited by a nearby spark as the one you affect by attaching the last cable connection to the negative post.) (When you make the last

connection, you are better off being quick and decisive on the connection; your description prompts me to ask about the size of the jumper cable and clamps.) Also, the second difference is the rescue car engine is running (so there is extra charging current.)

A comment: the huge spark indicates a very dead battery (internal resistance is very low), and maybe a bad short somewhere in your car (which initiated a battery death process; just guessing here), or both. See if you can find the cause and rectify it before continuing to jump.

## Scorpio Stuff

---

### **This is Ken Kiser's compilation of tips for the Scorpio.**

Here's a recap of tips I've learned for keeping these puppies clean and mean. Please feel free to correct any mistakes or add your own tips. Usual disclaimers yada yada. Know what you're doing if you work on major systems. Get the factory manual

---

- **Black cladding and bumper molding inserts**

Shoe sole edging (black) is the best thing I've seen for restoring the black color. Nothing else- silicone, cleaners, wax, etc- worked nearly as well. Just so happens it's also good for restoring the black to door handles, outside mirrors, front air dam, etc. Try it on a hidden spot first, to get your technique right. 1/4" to 3/8" natural bristle brush works good-the edging is really a paint.

---

- **Leather seat cracks**

Unightly cracks on leather seats: leather shoe dye. Mix a little white with black to match the raven color. (no experience with tan, etc). Mildew and/or mold on leather seats: ammonia. Also removes the stains. spray bottle... I didn't try wiping it off the rough side. One cleaning application doesn't seem to harm the leather. Then dye if necessary and treat.

---

- **Radiator fan clutch**

The Bronco II V6 clutch can be used. It must be 'shortened'- the large attaching nut needs to be ground down some. And>the fan attachment needs some attention. 86/87 F150 pickup straight 6 clutch is short enough; fan attachment needs some attention. The Bronco fan has a smaller diameter bolt circle

---

- **Similarities between the Scorpio and the Bronco**

Water pump: The Bronco II V6 2.9 water pump appears to be identical to the Scorpio unit. Starter: The Bronco II V6 2.9 starter appears to be identical to the Scorpio unit

Flywheel, automatic transmission: The Bronco II V6 2.9 A4LD flywheel is not identical to the Scorpio unit. But it can be used. The trick is a spacer that puts the Bronco flywheel the same distance from the back of the block as the stock arrangement. I cut a Scorpio spacer in approximately half

---

- **Oxygen Sensor**

Oxygen sensor: These are generic, so any 3-wire unit will work. The Scorpio wiring harness off the old sensor needs to be spliced in to get the right length. Scorpio units cost \$120+. Generic units cost ~\$40. Reports suggest NTK brand may work better than the Bosch units. The fuel/spark system requires a lot of functioning sensors. A way to read diagnostic codes is required. Usable code readers start at ~\$40.

---

- **Instrument Cluster Bulbs**

Some of the sockets (the tall ones) have bulbs that are soldered in. These soldered bulbs can be repaired by pulling out the old bulb. I used plug wire pliers. Take a new 194 bulb and straighten the wires; slide it down into the socket, making sure the wires of the bulb lay on the socket's circuit board contacts. The \*really\* industrious might want to solder the wires to the contacts, but I've found it's not necessary

---

- **Leaking Radiator Tanks**

The plastic tanks sometimes (often?) leak at their seals. It's possible to repair this, assuming you have a basically sound radiator. Bend back the tabs with small side-cutters (nippers) all the way around each tank and remove them. Make sure the seal is pliable. I use a smoothed-down band saw blade to push the deposits out of the core tubes. Clean it all up (transmission cooler, too); lay a \*thin\* bead of hi-temp silicone in the gasket groove on the radiator; lay in the gasket/s; secure the tank with water pump pliers. Leave it for a day. Testing it: one way is to lay it flat on its front, fill with water, and let it sit overnight. Check for leaks

---

- Cutting Tibbe Keys at home

Duplicate keys: The Tibbe keys (late 88 and 89 cars) can be copied at home with a little patience. Here's the procedure: These folks have a good explanation of the depth/angles on a Tibbe key: [www.flyingcircuscars.com/tibbetb.htm](http://www.flyingcircuscars.com/tibbetb.htm). Jaguar uses the same brand, but they use 8 cuts on the blank; Scorpios use 6. Also, there are a total of 4 'depths' on the Scorpio keys vs 3 on the Jag (They have a useful warning: any Tibbe key will lock a Tibbe lock. Don't lock your keys in your car.) Here's a drawing of the jig I made: [www.rebirthing.ws/scorpio/jig.jpg](http://www.rebirthing.ws/scorpio/jig.jpg). It holds the key and lets you turn it to the appropriate angle. I made mine from pieces of a bed frame, about 6 inches long. Cut a semi-circle out of each to clear the key head. I put a washer between the plates, bolted them together (two 1/4 inch bolts), and then drilled down the middle to make the slot for the key shaft (drill size slightly smaller than the shaft). Cutting the key requires frequently comparing it to the original...right cuts in the right places, at the correct angles and depths... I used the band saw; it could be filed, I suppose. Makes a nice meditation if nothing else. Here's a source for blanks: <http://www.maziuk.com/locksmi03.htm> 10 delivered to my house for \$14.45. You'll want the S30FDP

- A/C Compressor alternate sources

Some mid-80's Mazda RX-7s used essentially the same Nippondenso unit. I have swapped one of these in with good result. The clutch is also the same. The distinguishing factors of the Scorpio compressor (vs. other cars) are the 6 and 12 o'clock mounting tabs, and the arrangement of the outlets. The XT unit is the same (as is the evaporator)

- Fixing Scorpio Instrument Panel lights by Bill Stobbe

**Q:** About half of the instrument panel lights in my '88 Scorpio aren't working, or work only part of the time. I can't see the temperature or fuel gages at night, and some of the idiot lights don't appear to be working.

**A:** Instrument lights are not too hard to repair.

Tools:

- o small cutters (optional, I used small screwdriver to break the wire leads in the socket.)
- o pencil soldering iron
- o small tube of wire like solder
- o small jar of plumbers flux
- o #194 instrument bulbs.

Clip out the old bulb from the white plastic housing. Now the harder part. The 194 bulb comes with bottom wires folded under, and the wire is doubled. Bend each folded under "leg" down so you have two legs of double wire. Scrape these "legs" with sandpaper.

Now you need plumbers soldering flux. Dip each sanded "leg" into the paste. Heat it with the gun and melt solder onto it. If it doesn't stick, sand the leg again. This pre-application of solder to the leg is called tinning. Be sure that both legs of wire are properly tinned before attempting to put the bulb in the socket. Now bend both legs to the approximate width of the socket sides. Push bulb into socket. Re-adjust width till each leg is in contact with the socket base. Put another small blob of flux on each leg inside the base. Put the iron thru the hole in the base of the socket and heat the flux while at the same time putting a dab of solder on the joint. It should adhere easily.

- Scorpio key source by Dave Compton

FYI, Helm Inc. can make a key for Scorpio from the VIN. \$25 for each key.

1-800-782-4356 Ask for the Ford Support Group, then push 1.

**A list member asks:** Hey Dave, Are you sure dude?? That would be great!! Last I had talked to HELM the machine was broken and they had no intention of fixing it at that point. Course that was about a year ago.

**Dave Replies:** I'm POSITIVE. Greg Larson's brother just got a key from them about 2 weeks ago.

**Greg Larsen adds:** That's correct! The price was surprisingly reasonable so he got two of them. I think the only thing they required was the VIN and he received them

by mail in less than a week.

- 
- Jaguar key fits Scorpio and key code location by Jon Ault

**Q:** I asked the local Jag dealer about Scorpio keys and they can cut them from an 8 digit code, where can I find this code? Is it printed on the door jam sticker somewhere?

**A:** Should be embossed on one of the door lock cylinders.

- 
- Scorpio kick down cable by Paul West and Jim Wirt

**Jim wrote:** This could also be caused by a misadjusted cable on the kickdown solenoid. This is on the driver side of the A4LD. The shop manual calls for a special tool to get the proper slack into the cable, but I found I was able to adjust mine without it. Just shortening the cable length so that there is little slack but no tension did the trick for me.

**Paul Adds:** Thanks to everyone who wrote suggesting causes for my Scorpio's automatic kickdown not working. Jim Wirt's suggestion did the trick. There was no tension at all in the kickdown cable connected to the solenoid on the side of the transmission. Loosening the two bolts that hold the solenoid and moving it forward corrected the problem.

- 
- Scorpio blower fan motor removal by Ken Kiser

**Q:** Can anybody explain to me how to take out the blower fan motor for my 88 Scorpio

**A:** Pretty straightforward... pull the sheet metal panel right behind the distributor. To do that, among other things, you have to remove the a/c lines (and subsequent recharge, etc). Or you can cut the case and

save your Freon. You still have to pivot the sheet metal around the a/c line to get clearance.

Anyway, remove the blower control module, the temp sensor on the case, the vacuum line to the diaphragm on the case... Then remove the clips, pull off the top half of the case, and there's the motor.

Some say it's easier to take the hood off. I'd say it depends on your dexterity. Ken.

**A:** About your blower. You want to use the 'cut air box' method to do this job. I know the purists get all bent out of shape about trashing our prized Scorpios, but that's BS and it does not trash the airbox, just makes repair way easier!

The way to do this is simple. Take off the control module on the top of the airbox and disconnect the electrical fitting. Now, starting at the middle of the ends of the rectangular opening, cut straight down to the split in the airbox case. Use a fine saw, I used a saw called the "Razor"; a great cutting tool. Now go around the front half of the airbox and remove the clips that hold it together using a small screwdriver. the ones next to the firewall (wildfirewall?) can be hard to reach, use a longer screwdriver. Make sure you save about four of these.

Once the clips are off, the front half of the airbox comes right off, and there is your motor. No fuss, no muss. Reassembly is simple, and you don't need the clips on the front, just do two per side. The cut is nearly invisible and there is no change in performance. This is a much better solution than dumping your AC and pulling the whole airbox. Save that operation for when the heater core fails!

Homer Shannon

- 
- Scorpio Alternator warning light syndrome by Jim Wirt

I just got bit by the "burned out Scorpio alternator warning light syndrome". If the Scorpio alternator warning light is burned out, the alternator will not start charging. Looking at the wiring diagram, it is not obvious what is going on here since they show the alternator as a black box.

The explanation from the old IMON archives says "...the current from the bulb supplies the field coil in the rotor until it "bootstraps" itself, and then supplies its own field current internally".

Pay attention to your warning lights when you start the car. If they are not all on when you fire it up, they can't help you when you need them.

- 
- Scorpio Oxygen Sensor replacement Info by Jim Wirt

**Q:** Any experience out there that indicates whether the 13053, or for that matter, a 4-wire "universal" (for Fords, of course) will work on the Scorpio? TIA Anyway, any similar sensor will work, assuming you get the same number of wires.

**A:** The stock Scorpio HEGO is a 3-wire unit. The Bosch unit I have in front of me has one black wire and two white wires. The white wires are the heating circuit and connect to the black/red and the brown wires at the connector near the battery. The blue/white wire is the EGO signal wire back to pin 29 on the ECU. The Scorpio does not run a separate EGO ground wire out from the ECU but grounds the EGO sensor case through the exhaust system and engine/chassis grounds. (Pin 49 is the "EGO ground" but this is just grounded at pin 16).

You can use a 4-wire sensor. You have the three wires described above with the fourth being a dedicated ground. If the sensor you buy is not also grounded through the case (just check for continuity between the 4<sup>th</sup> wire and the case), you can simply extend the 4<sup>th</sup> wire and connect it to a good chassis ground. (Or you can knock yourself out and run it all the way to pin 49 on the ECU!). If the sensor is also grounded through the case, you don't necessarily need the 4<sup>th</sup> wire at all. A good ground for the EGO sensor is important though, so you may want to use it anyway. Tony Vissoc writes:

---

- Scorpio Fan Troubleshooting by Tony Vissoc

**Q:** My Front fan does not come on. I believe it should be, based on the 100F temps we've had here recently. The AC works surprisingly well (still R-12.) I haven't tried to apply power direct to the fan to see if it comes on, but it does spin freely. From what I understand, the fan should come on if the coolant reaches a certain temp and/or if the AC system reaches a certain pressure. So, I'm guessing that it is more than just the temp sensor in the radiator. Unless, both conditions have to exist for the fan to kick on (high temp/high pressure).

**A:** Either one can turn it on.

**Q:** Where should I start my troubleshooting? The 30amp fuse looks fine in the fuse box. Is there a relay involved in this circuit? Which one is it? There are several that mention AC. This is an '88 Scorpio, if it matters.

**A:** It does. Originally, these fans came equipped with two relays (for two speeds). If someone has bypassed the fat ceramic resistor on the fan frame, that's fine. I'd check the fan directly first. If the fan works and you can switch it on by bypassing the rad or a/c switch, you've got a break upstream- switch, relay/s, wiring, etc.

If it matters, the 89 fan (not Bosch) is noticeably quieter than the 88 (Bosch) unit. The main problem I've seen in these motors is that the magnets come unglued from the case, stopping the rotor. Easy to fix.

---

- Scorpio rear Brake questions by Ken Kiser

**Q:** Yesterday I attempted my first ever brake job and I thought I had all my bases covered but I ran into a couple of problems. First, how do I get the rotors off? I have the caliper and the retaining clips off but the rotors don't want to budge. What do I need to do here, apply some heat or have I missed something?

**A:** I used a big screwdriver to loosen the pads slightly from the rotor (assuming you've removed the two caliper bolts from the back).

**Q:** Second; when I tried to screw the rear caliper piston in it wouldn't budge and yes I do have the right tool and I followed the instructions in the shop manual to a tee. It doesn't say it in the manual but do I have to open the bleed screw and do I have to bleed the brakes after. Also how much force is needed to get the caliper to move ?

**A:** I had to use a special tool to push the rear pistons back into the caliper (after I had turned and turned...) It's a straight bar (gear puller, really) with a bolt 90° to the bar, in the middle. The bar pushes against the two 'claws' of the caliper as the bolt pushes the piston back in.

---

- Scorpio blower motor removal by Jake Delgado

All, I had some requests for my experiences changing the blower motor out, once I complete it so here it is, step by step.



Disclaimer: Take these directions with a grain of salt, I'm writing this from my very lousy short term memory, inaccuracies are to be expected. Oh and if you screw up your own car during this process, don't come crying to me! ;)

1. Remove the black plastic cover between the firewall and the cowl grate. There are three screws at the upper part of the cover. On the lower side it just clips into the firewall, so lift gently to remove it.
2. Remove the cowl grate. First remove the windshield wipers. The upper fasteners on the cowl are a clip type fastener with a plastic "screw". With a small screwdriver, remove the small cover over each screw. Gently back each screw out until it sticks out about  $\frac{3}{4}$ " of an inch. These will have a tendency to twist off so be gentle. Place a small screwdriver between the grate and the windshield at each fastener point and pry gently. Once the upper fasteners are loose, lift on the lower side of the cowl to pull the lower fasteners from the body. Unhook the washer fluid line and set the cowl to the side.
3. Remove the small access panel in the top of the Blower/evaporator housing (three screws). The panel is sealed with an adhesive, just pry up gently to remove it.
4. Remove the screw that connects the air door actuator to the air door arm. This is the small vacuum actuator on the right side of the blower housing
5. Using a coping saw, make a cut from the opening in the top of the housing, down to the split in the housing. I would recommend following a line or cutting right where housing begins to widen slightly. The right side is an easy cut. On the left side you have to be very careful not to cut or damage the A/C lines. Neither cut is more that 3 or 4 inches long. Do NOT use a rotary tool as I attempted to. My cuts were very uneven and I had very big gaps in places. I found the coping saw cut well, was easy to control and left a very small gap.
6. Cut the two vertical supports inside the blower housing.
7. Remove the two screws on just below those supports.
8. Remove the small C-shaped metal clips at the seam of the housing. Some of the clips cannot be reached due to the firewall. Those will pop off as you remove the housing
9. Unplug the connectors going into the housing
10. Rotate the housing half and being to lift gently, forcing the clips on the back edge to come loose. Once all clips are loose rotate the housing and lift it out.
11. The motor is held in by a strap in one screw. Remove it and lift the motor out of there. Don't forget the ground wire! If you purchased the Siemens P/N PM3534 from AutoZone, it will come with extra leads on a harness, which I believe is for the Scorpio. Clip the end of the "Hot" lead (black with red stripe) from the old motor. From the new motor, clip the Black/Red wire and the brown leads coming from the motor, right where they meet the connector. Solder and heat shrink the old hot lead onto the new lead, make sure to slide the box grommet on the wires before doing so. Also make sure the overall length of the lead is at least as long as the old lead. Do the same for the ground (brown) lead.
12. When reassembling I used black gasket maker to seal the seam between the two housing halves. I then used a piece of auto weather stripping from AutoZone to seal up the gap created where I cut the box. Unfortunately I had a big gap to fill, but if you use a small coping saw blade, form-a-gasket should work. If you let the gasket maker set, you will not need to worry about replacing the clips behind the firewall. Just replace the side clips and the two screws inside the housing and that will be more than enough to hold it.
13. Finally, when replacing the cowl grate, the plastic "screws" can just be tapped in.

Sorry for such a long post, but I think this covers it.

---

- Scorpio Blower Motor Source by Ruben James

**Q:** Does someone have the part number and source for the Scorpio blower motor? If I remember correctly it's made by Siemens.

**A:** Sure...Autozone....\$93.99 order only...PM3534..Get it in 2 days generally...



---

- Scorpio clutch fan alternate source mod by Andrew Smutniak & Others

**Q:** Could you specify which model(s) and year(s) have the right clutch and could you describe the adapter further? Inquiring Scorpio minds want to know cheaper alternatives to expensive or obsolete Ford parts....Thanks!

**A:**  
The Bronco II 2.9 V6 clutch can be used with modification/s. Grind some height off the attaching nut (some have an unthreaded portion that provides a template). Either adapt the Scorpio fan or the Bronco fan.

The Scorpio fan can be attached by making a 'stepped' washer- Side view looks sorta like this

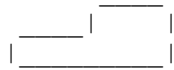

The lower side secures the inner ring on the fan to the clutch. That ring needs notches to clear the bolts to the clutch (the bolt pattern is different between the two).

Or, cut a 1/2" length off each blade of the Bronco fan. I pulled the top fan shroud, mounted the fan/clutch, ran the engine at idle, and used a big rasp to file the blade ends. This setup's been working for 2 years now.

I'll adapt the Scorpio fan next time.

Other options: the clutch from an early 80's F150 straight six engine can be adapted (more work than the Bronco fan). And, I hear Hayden is starting to make a Scorpio-specific replacement. Prices I heard were around \$150.

- 

I just replaced the fan clutch on the Scorpio yesterday. Our local "O'Reilly Auto Parts" store (national chain) carry an OE replacement clutch for the Scorpio with a lifetime warranty made by Hayden, part #2581 for \$80 and it fit perfectly. I'm a happy camper.....Chuck

---

- Scorpio water pump source by Jerry Chandler

**Q:** I have to change the water pump in my Scorpio and was wondering if there was anything that I might have to be on the lookout for in terms of problems. First, are Ranger water pumps the same as Scorpio water pumps? I need one and have found that a water pump for a Scorpio costs TWICE as much as a Ranger, which seems odd to me since the engines are almost the same if I understand correctly.

**A:** I thought they were the same until I tried to put in a used Ranger pump. The impeller blades on this particular pump were a little too long to clear the Scorpio timing cover. I haven't gone to a parts store and compared them.

**A2:** I replaced my water pump last fall. I found that the Scorpio Water Pump could be found thru chain stores like Advance Auto or AutoZone, BUT the one they list costs about \$100!!! yikes!

I found a great source: Car Quest Auto Parts ([www.carquest.com](http://www.carquest.com)) they have a rebuilt water pump for about \$40 and has a lifetime warranty. At that price, you can afford to replace it every couple years..especially if you get rid of that damn OEM fan and clutch and install an electric radiator fan with adjustable thermostatic control (cost me less than \$40 for fan and control switch).

If you need to replace the water pump, I strongly encourage you to take the opportunity to clean up the cooling system while things are apart.

1st: remove the rad and take it to a good local rad shop and have them flush or boil or whatever they do to get as much crud as possible out of it.. and a thorough leak test. I think I paid less than \$25 for this.

2nd: While you have the rad out of there and the pump off the engine, take a hose with medium water pressure and force it into one of the two water pump ports on the engine and watch the crap that comes out the other port. Then.. when it runs clear, reverse and put the hose to the other port.. do that back and forth a few times.. amazing stuff comes out of most of our engines.

3rd: this is also a good time to take a close look at belts and hoses. Belts are cheap and if it has been a while, just do it. Hoses are a special order from BAT or Rapido or OPMD (I think).

4th: If you haven't done it yet, add the transmission cooler up front in that lower bumper cutout and disconnect the lines to the radiator. This relieves the radiator from having to absorb temperatures above 220F (upwards of 400F) and lets the radiator do a more efficient job. Also, the transmission fluid will cool better. Excellent win/win heat dissipation upgrade! I have pix of this mod too.

5th: I took the opportunity to remove my engine driven clutch rad fan and replace it entirely with an electric fan controlled by an adjustable thermostatic switch. Other than modifying the Scorpio on this one item away from stock, it is a win/win rehab. You get better cooling and you gain back a few HP that are lost to driving that rad fan... the added power is noticeable when you take it out the first time after the rehab.

Rather than buy an aftermarket electric radiator fan, I chose to search out a good strong OEM fan available from your local auto salvage yard. Our radiator measures: 16 X 24 (core). I found a terrific fan! It is from a 1990 era Dodge Monaco or Eagle Premier (same car). I paid \$20!! So I bought two! First of all, it is the thinnest fan I could find that measured 16 X 16. It covers 2/3 of the radiator with a super nice shroud and slips easily between the radiator and the end of the shaft where you took off the engine driven fan. The shroud on this thing has flanges that match perfectly up to the upper and lower flanges on our radiators. I was able to simply drill four holes and bolt it on with 1/4" bolts & nuts. Electrically, I bought the Imperial Adjustable Thermostatic fan switch from Advance Auto for about \$19. I hooked it up with a standard automotive 25/30 amp relay to protect that switch. I currently power from a lug at the + battery terminal. This month I plan to add a lighted switch in the cockpit so that I can SEE when the fan is on and override the thermostatic switch if I choose. I adjusted the fan to stay on for just a minute after I turn off the engine.. this can be fine tuned. I REALLY like the idea of being able to exhaust heat out and away from the engine AFTER you turn off the engine. This would be especially good for XRs to assist with heat soak prevention.. and is a good idea for our Scorpions too.

- 
- Scorpio transmission shifting problems by Dimitri

**Q:** A recent suggestion that the vacuum servo may have something to do with a shifting problem from first gear is, I believe, incorrect. That servo only controls the torque converter lockup.

**A:** You are confusing vacuum servo and vacuum modulator. The vacuum servo, clipped to the airbox, does indeed deal with converter lockup. It does not \*control\* lockup however, it energizes the lockup solenoid (whose full name is converter clutch lockup inhibiting solenoid), which \*disallows\* lockup at vacuum conditions between 5"hg and ambient. It does not cause lockup, that is done the old fashioned way, with fluid pressure and valving.

The vacuum modulator, mounted to the passenger side of the trans just above the pan and ahead of the tail, does indeed affect shift points. It uses engine vacuum to sense the demand for acceleration of the vehicle. The closer to ambient, the more demand. The vacuum acts directly on the diaphragm, which acts directly on a shift delay valve in the valve body, causing the tranny to shift earlier the lighter the acceleration. When the modulator fails it cannot act on the valve and the shifts always take place as if there were little to no vacuum present (like at WOT/high acceleration demand), regardless of the actual demand.

**A2:** Correction to my previous email: The use of the term "servo" in this case is actually completely wrong, and the lockup is dealt with by a vacuum switch. The modulator could in fact be called a servo, but usually is not.

---

- Scorpio Fan Clutch Test by Edward Lijewski

I came across this test for the Scorpio fan clutch from Mitchell International; it makes more sense than anything I've seen recommended in posts on checking for a failed clutch---except that (as happened in my case) if there are clear signs of viscous fluid leaking from the clutch assembly in which case the clutch is toast already.

"In case of engine overheating or insufficient air conditioning proceed with following tests:

- 1) Start with a cool engine to ensure complete fan clutch disengagement.
- 2) Cover radiator grille sufficiently to induce high engine temperature.
- 3) Start engine and operate at 2000 RPM. Turn on air-conditioning if equipped.
- 4) a fan roar will be noticed when fan clutch engages.

NOTE: It will take approximately 5 to 10 minutes for temperature to become high enough to allow engagement of the fan clutch. While operating engine under these conditions, observe temperature light to prevent overheating. If hot light comes on, remove cover from radiator grille.

- 5) When clutch engages, remove radiator grille cover and turn A/C off to assist in engine cooling.
- 6) After several minutes fan clutch should disengage. This can be determined by a reduction in fan speed and roar. If fan fails to function as described, it should be replaced.

NOTE To avoid premature cooling system wear, always use the manufacturer's recommend coolant products and coolant mixture ratios."

---

- Scorpio Moonroof woes by Dimitri <= goofing off at work!

**Q:** I need some help with an unwilling moonroof motor. Roof won't move in either direction, just hear a click and no movement. I tried to remove the motor, but could not pull it off after removing the 3 screws/bolts that hold it in place.

**A:** That's all you need to do. Wiggle it a little while pulling and it will slide off of the actuating post. The post is split and provides outward tension against the motor gear, holding it on.

Hate to be the bearer of bad news, but the motor is not likely to be your problem. The moonroof is actuated by two cables that run within tight fitting steel tubes. What happens is that when the rear roof drains clog up (and they always do unless you cut out those tiny slits), the whole cavity fills with water. The tubes in which the cables ride are open ended, so the cables become immersed in water and eventually rust solid into the tubes. The only way I have found to free up a stuck mechanism is to throw it in the garbage and replace it with one from a parts car.

You can test this very easily by obtaining a manual window crank from an XR, or in a pinch you can use a hammer to gently force a 10mm 12 point socket on the actuating post. If you cannot turn it manually the mechanism is frozen.

---

- Scorpio Trunklid wont Open by Jake Delgado

**Q:** I cannot get the trunk lid open on my Scorpio. I have tried everything. How do I get to the lock assembly without tearing up the trim inside. I think that maybe the solenoid is not working. I hear the thunk that it makes but it will not open. Any ideas????? help!!!!!!!

**A:** Is the key lock working on the car? Have you tried having a friend pull up on the door while operating the lock with the key? There is a spring inside the lock that is supposed to hold it open after you press the button or use the key to open the lock. If that spring break (as is the case in my '88) the lock will remain locked because the door does not lift enough to keep the lock unlocked without the spring. If this gets the door open and the spring is indeed bad, you can adjust the two feet on either side of the door to lift it slightly when you release the lock so it will stay unlocked. If you don't have a shop manual, I can describe how to do this adjustment for you. I hope this helps!

- 
- Scorpio Brake Accumulator Sources by Bill

**A:** The rear-wheel drive Lincoln Town Car from around the same year used the same accumulator if you want to try hunting in the wrecking yards. I have not had an accumulator fail, but I have a wrecking yard spare just in case. If you are definitely looking for a new one, here is a message that was on the list about a year ago:

Here is a tip for Scorpio owners needing a brake accumulator. I purchased one from Prior Remanufacturing [ 1-972-494-4254 ]. They are in Garland TX, I order ed one and received it two days later via UPS. Cost \$99.95 plus shipping. Tell them you want a Scorpio Teves II accumulator. It is slightly larger in diameter than the OEM unit and does not have a socket on top for an allen wrench like the OEM but has like a hex nut on the bottom that takes a 24MM or 15/16 wrench. There wasn't room to get a wrench on it so I tightened it with a large pair of channel locks. Also comes with the O-ring. Mine is working well.

Prior also remanufactures many different types of antilock brake units. It costs \$540 to do a Scorpio Unit. They rebuild the entire unit. This includes the master cylinder part, the high pressure pump, and the pump motor including new brushes and a new accumulator. Then they thoroughly test it. Has a three year warrantee.

BAT wanted \$211 for an accumulator with a six week delivery, and an Alfa place in CA wanted \$230 for one.  
I hope this helps!

---

- Opening a Scorpio Hood when the hood latch cable has broken by Jim Wirt
- Q:** Any suggestions on how to get the hood open when the hood release no longer pops the latch?
- A:** <SCORPIO HOOD OPENING PROCEDURE>
- First, these cables do not usually break. What happens is that a small plastic bushing disintegrates and lets the cable end pop up out of the release lever. Slamming the hood contributes to this cable coming loose.

You can get the hood open this way:

Lay under the front of the car face up with your head under the fan. Use your right hand and reach up through the fan. If you rotate the fan up with your right hand/arm you should be able to reach a small opening in the frame across the top of the radiator. You will be able to put a couple fingers through the hole and feel around for the release lever and the end of the cable. The easiest thing to do is to hold the cable end down into the slot on top of the release lever while someone slowly pulls the hood release in the cabin. If this does not work (the cable could actually be broken), you can push the end of the release lever toward the driver's side with your fingers while someone else pushes down slightly on the hood. Pushing down on the hood will release some of the tension on the mechanism making it easier to push the release lever.

</SCORPIO HOOD OPENING PROCEDURE>

This description takes a lot longer to read than it does to actually accomplish the task. I have done this several times now on my two cars and for others owners and it takes about 15 seconds to pop a Scorpio hood. After you get the hood opened, if the cable is not broken, you can re-secure it with a couple of small cable ties to hold it into the release lever.

**A2:** An excellent point which reminds me of another excellent point.

The hood release cable is adjustable with a plastic thumb nut in the steering column. I would suggest that ALL Scorpio owners check the hood release handle and make this adjustment on all their Scorpio's and parts cars. When properly adjusted the hood release handle should return up and to it's home position, touching the bracket. What I've found is that most hood release handles hang a little limp which allows the slack in the cable and cable sleeve that causes this problem. [Cable] Tie, optional.

An ounce of prevention is worth a pound of flesh reaching in between the engine and radiator while laying on frozen ground.

---

• Do I have a cracked cylinder head on my Scorpio ? by Jim Wirt

**Q:** Ok so who's changed one and do you have any tips? I'm going to double check on this (with a compression check) but I'm 99.9% sure that I've got a blown head gasket. Everything ("magical" coolant leak which I pressure tested and overheating which at first I thought was just gauge) leads to the head gasket. So I'm really just looking for real life experiences so I have some kind of idea as to what I'm getting myself into.

**A1:** I went through this a while back- low compression on one cylinder, chocolate mousse in the valve covers, etc. So, I got a pair of used heads, had them magnafluxed, put them on, and... no change. Turns out I'd lost piston rings on one cylinder. I put a junkyard engine in, and it's been fine since. Replacing the heads took about three days, doing it in my own (tiny) garage. It's not hard, just a little tedious.

**A2:**

Hi Jes and All,

Changing the heads or head gasket on the 2.9L is not too bad a job. As others have said, this is most likely the very common "Cracked Head Syndrome". Often the leak is so small that the coolant will evaporate before it can get down into the oil sump. Symptoms will be mysterious coolant loss and a bit of "chocolate mouse" on the inside of the valve covers.

If you have to do a head change, I think you will be wasting your money using the stock heads. The World Products heads are a bolt-on replacement for the OE parts and have significantly beefier walls. You can get the heads bare or built up with valves, springs, etc. I think I paid about \$450 for a built-up pair. If I remember right they weighed about 6 lbs more each than stock. The only thing you need to be aware of is that the WP heads have 10mm holes (like the later model 2.9L) for the accessory mounting bolts instead of 8mm stock. This entails hogging out the hole on the power steering pump mounting bracket to pass the larger bolt and getting some 10 mm bolts of the same length. No big deal.

As Jerry said, you will need new head bolts as they are Torque-To-Yield and should not be reused. You will of course need a new upper and lower intake manifold gasket set. Felpro makes a good one as well as the head gaskets. Pay attention to the use of RTV at the appropriate spots when installing the lower intake manifold gasket or you will get oil leaks at the front and back.

When cleaning the old head gaskets off the top of the block, keep as much of the debris as possible out of the oil and water passages and the cylinders. I stuffed small pieces of white rag into the passages and was careful to remove and account for them all afterward. I also used the trick of packing grease down in the gap between the pistons and cylinder walls to keep small grit and debris from reaching the rings. After you are done cleaning, you can just move pistons down and wipe the grease and crud off the cylinder walls.

The only thing I had trouble with at first was getting the distributor to reinstall. With everything aligned just the way it was when I took it out, I just could not get it to drop back into place. I found that putting a wrench on the crank pulley bolt and turning it ever so slightly one way or the other let the distributor gearmesh properly and drop into place easily.

I will strongly recommend getting the Helms shop manual before starting this job. You will need it for torque specs, disassembly/reassembly order, and all the small details that make the job a lot easier.

Regards,  
Jim Wirt

- 
- Where to find a replacement Scorpio Fuel Pressure Regulator by Dims

**A:** For a Scorpio, ask for a regulator for a 1988 ford ranger with a 6 cylinder (the only 6 available was the 2.9). It is the same as the one used on the Scorpio, just doesn't have the black rubber cap. The regulator for the XR was used in 10 billion other cars. Any EFI 2.3 or 5.0 94 or earlier should work fine.

---

- Cause of Chronic Scorpio front end (crank) oil leak

**A:** If you've got chronic front crank leak, a friend of mine gave me a heads-up. Harmonic balancers leak oil if they have any wear groove. Duh. 13 years \*in\* the automobile business, years of maintaining my own cars... I've never heard of this. He says "get a sleeve for the shaft". Just so happens, NAPA sells a metal press-on repair sleeve for the harmonic balancer shaft-\$8.99.

It was listed as a repair for the Bronco, so you won't find it under Scorpio. Balkamp 600-2495. Same \*seal\* as the Bronco, however, regardless what the parts books say. I purchased timing cover seals for each engine, and they were identical parts. They list a sleeve for the rear of the crank, too. NOS99237. \$40



## Sensors

---

- Bosch O2 Sensor notes by Tim Lewis and Wally Schmidt  
Bosch O2 sensor Autozone part #12909 (I think) \$27.99 BIG IMPROVEMENT!!  
Be very careful when removing the old one as not to strip the threads ease it back and forth to get rid of the rust.

That was my experience, too. Big difference. The guy at my AutoZone pointed out that the threads are the same size as the larger-sized sparkplugs and sold me a "chase" (like a tap) which was great for cleaning out the threads. Hopefully that will make the next replacement a little easier.

---

- What is the MerkMeter and how do I get one ?  
Don Answers: I just put in my Wirt Meter that I got at Carlisle (Excellent weekend!). The meter shows below lean if I let off the gas and it shows full rich if I peg it. Led's search nicely when driving at steady state, goes to rich as soon as I touch the pedal. Very neat easy installation, about 25 minutes. All the connectors are high quality and the directions are very clear. Thanks to Jim Wirt  
Source for the **MERKMETER** (Merkur Specific A/F monitor that installs in the instrument cluster)  
<http://www.bitsprings.com/afmain.htm>
- 

- How to set the TPS by Richard Curtis
  1. Disconnect the IAC wiring harness, the idle will drop. If it won't idle at all with IAC disconnected, turn the idle adjustment screw IN until it at least idles.
  2. Use a 3/8" wrench or 10mm (?) to turn that idle screw thingie in or out until the tachometer reads 750 rpm. You'll probably have to remove at least one of the two 8mm bolts attached the IAC to the throttle body in order to access the two screws securing the TPS. Be careful of the IAC gasket.
  3. Then set TPS voltage. The TPS -- as I think someone else has already replied -- is a black plastic thing that sticks on the back side of the throttle body (on the driver's side). It's about the size of a matchbook. Has three wires coming out of it... red, green, black. The green one is the only important one for setting TPS voltage. Hook up your positive lead from multimeter to the green wire (you can prick it with a safety pin or similar or do I as I did and hook up a lead from the green wire so you can hook up to it a WHOLE LOT easier than trying to do the safety-pin thing).
    1. Then hook the negative lead from the multimeter to a good ground.
    2. Turn switch to ON but not START.
    3. Turn on voltmeter to voltage.
    4. You change TPS voltage by loosening the two screws that secure it to throttle body and moving it SLIGHTLY until you get correct voltage reading. set it somewhere between 0.90 volts and 1.0 volts (opinions vary; I haven't noticed a lot of difference in performance at any setting between 0.90 and 1.0). Do NOT overtighten the TPS screws (ask me how I know).
    5. After tightening the TPS screws, check the voltage once again to ensure it hasn't slipped.
    6. Before turning off ignition and unhooking everything, push the throttle to WOT slowly and observe the DVOM. It should eventually read 4.5volts or better and get there in a smooth fashion. If it spikes at any point (which would be the "worn" part of the TPS), you will need to replace the TPS. Most folks recommend Motorcraft parts only.
    7. Turn off ignition. Unhook multimeter. Reattach IAC wiring harness. Car should now idle at 900 rpm.

If you then change the idle by screwing in or out the idle adjustment screw on the throttle body-throttle linkage, the TPS voltage will change. They are related. If you do that for any reason, you'll have to reset the TPS.



to set the timing, loosen the distributor hold-down bolt. It's very difficult to see but is on the engine side of the distributor. Look closely; there's only one. Loosen it until you can turn the distributor. Set timing (13 degrees for manuals; 10 degrees for automatics). Tighten bolt.

- TPS Notes by Paul the Brit.

Matt, it's very unlikely you are getting negative voltages with respect to chassis ground. You have your meter connected the wrong way.

There are three wire on the TPS. One is ground, which is connected to chassis near the EEC. Identify this one with the ignition turned off and the meter measuring continuity to ground. The wire color is Black/White and is connected to the pin nearest the right angle corner of the TPS connector .

The next pin is the reference voltage generated by the EEC. The wire color is Orange/White. This should measure +5V wrt ground with the ignition on. Remember to take the meter out of continuity mode before measuring voltage!

The last pin is the 'wiper' of the TPS. Wire color is Dark Green/Light Green. This is connected to pin 47 of the EEC and applies a voltage proportional to the throttle butterfly position.

To adjust, slightly loosen the screw which runs in the oval shaped slot at the top of the throttle body. Hook up the meter between the Black/White wire (Ground) and the Dark Green/Light Green wire (wiper). Do not use the engine block or chassis as your ground reference as this can vary by a few tenths depending on condition of your ground straps. Turn the ignition on and adjust the TPS by rotating it until the meter reads 0.95V - 1.00V. Having found that position snug down the screw and recheck. Move the throttle linkage a few times and recheck for 0.95V - 1.00V. Some people connect to the wire by pushing pins through the insulation. A better solution is to either make up a cable from a scrap TPS connector and mating harness connector (as described in Allan Slocum's handbook) or to push pins down the side of the wire past the rubber moisture seal to contact the top of the pins. Job done. Note that before this is done, you should set the idle by warming the engine, turning off, disconnecting the ISC and adjusting engine speed to 750rpm. Then turn the engine off and reconnect the ISC.

Having done that, it's best to place an order for Allan Slocum's excellent EEC-IV handbook!

- [TPS part numbers](#) by Ian Glyn-Jones

**Q:** Ed Cushing asks Hi All, I bet you've heard this before. My Ford dealer said they didn't have a TPS for my '88 XR4ti. It looks to me to be exactly the same part as a Thunderbird Turbocoupe. So I asked for that. For some reason he says he can't get his computer to look it up. He did offer that if I could come up with a Part # he could probably help me. Anyone know the part # for the TPS on my '88 XR4ti?

**A:** There are 2 Ford Part #'s you can use on any year XR.

1. CX1135
2. CX1311

Note that the Turbo Coupe one will NOT work. The base is a larger size and will not fit into the throttle body of the XR. You could, however, swap to the Turbocoupe throttle body if you wish but to no benefit. Good luck.

**A:** I bought an OEM Ford TPS from my local Ford dealer in Jan of this year. \$58.94, with local tax. The part # is E6ZZ-9B989-A. If this does not work I can go back and get one for you, or give their number and you can call them. It was in stock no less ;>) Johnny Hinkle

- TPS Pinout by Andrew

3 wires:

Orange/White

5 V reference voltage



- Resistor in Series alternative to fix inaccurate temp reading by Steve Roberts  
When I did this some time ago on my '89, I used a 2 watt 20 ohm resistor, which put the needle at about the half way mark for normal operating temperature. In my case I just spliced in the resistor near the end of the wire which plugs onto the sending unit, then put on some heat-shrink tubing. It's been working fine for a couple of years now. I think I used a Mustang sending unit (not sure though).

=====

- Inoperative fuel gauge / Anti-slosh board by Carlos Olivares  
I have also had poorly working Fuel and Temp Gauges on my Scorpio. Traced my problems ( as per Helms manual ) to the small PC board on the back side of the instrument cluster. The manual calls this, the "anti-slosh PC board". I tried to re-solder all connections but ended up frying one of the chips. The board is covered with what I think is an anti-corrosion coating that makes it difficult to re-solder. The good news is, that all three chips are common stock items in most electronics supply stores and should not cost more than a few bucks for all three. Their numbers are # 2N5192, # LM 2904N, # PN 2907A. Replacing these chips solved my inaccurate fuel gauge, but I'm still having problems with my temp gauge. I've been hesitant about posting this fix since I haven't completely debugged it, but will update a post when I do. The last time I checked, FLM wants \$48.00 for this board. BTW I've drawn up a circuit schematic for this board in Illustrator 6, that I could send as an attachment, if any one thinks they could use it.

- Removed the anti-slosh board by Jimmy  
Read the emails on the slosh board, and as I was having an intermittent problem with the gauge just went down and pulled the board..whola..working fine..saves me from dropping the gas tank.(would rather have a gauge that floats than none at all) Thanks for the posts guys.

- Removed the anti-slosh board by Bill Stobbe  
What I do know is that disconnecting the slosh board does not effect a working temp gauge, and that it does fix a broken fuel gauge. My '89 is running this way. The Fuel gauge went kaput. My 1st try to fix it was the disconnect of the slosh board. It now does wander more than before on sharp turns. (needle dips depending on right or left) I don't care about that. There was an offer on the list of parts to fix the broken slosh board. I have them but didn't do the fix.

=====

- TPS Calibration help by Lih-Yen Hsieh  
Yesterday I spent about 2 hours to make the TPS test leads, and about 10 minutes putting in the new TPS plus the actual calibration. That's a 12:1 ratio of preparation to actual work, but IMHO very well spent effort. Of course much of this was due to my anal personality, and most people can do it much faster, especially if you replace the soldering part with quick splice connectors.

===== Secret #1 =====

I made three permanent test leads that were soldered to the TPS connector harness, from ~6" of 18G, colored wires with insulated female quick connectors. The solder joints were doubly protected with 2 layers of heat shrink insulation. I also made three short test leads w/ blade terminals. These provided me with a secure meter hookup. Note, this is not my invention.

===== Secret #2 =====

I removed the ISC, then put the throttle body back on to connect the TPS electrically. Removal of ISC provided all the access to the TPS retaining/adjustment screws.

===== Facts =====

- TPS P/N: Ford Motorcraft E6ZZ-9B989-A

- Wire identifications:

1. ckt 351 OW 18GA (pin 26 at the ECA: Vref, +5V.

Note, I heard someone fed 12V DC to this lead on a bench to calibrate the TPS.

I am not sure about the result.)

2. ckt 355 DG/LG 18GA (pin 47: TPS signal.)

3. ckt 359 Bk/W 18GA (pin 46: signal return.)

- Results

From 355 to 359 I was able to set The TPS reading to 0.972V (again, the last digit was purely because of my personality.) At WOT I got 4.65V. Not bad at all. And the adjustment took only 2 minutes or less! I even sat in the cockpit to floor the gas pedal to make sure from inside I got the

same WOT reading. Ahhh! The sensation of smooth idling (and shifting without mandatory toe-N-heel)!

---

- Temperature Sensor Identification by Jon

If it's a single wire slid over a screw post looking thing, this is for the instrumentation and is not available at part stores (at least by me).

If it's a connector style made of plastic, it is for the electric fan and controls when to turn on and off.

If it's at the top of the intake manifold, in between injector 2 and 3, it is the coolant temp sensor for the computer.

---

- Barometric Air Pressure (BAP) sensor troubleshooting by Larry Biles

Subject: Re: '86 XR "Rich Condition", Final Post, Problem Fixed!! (Bad BAP)

Hi Lou. The following is the answer to your question of "how did you trouble-shoot your BAP?". (I must remind you that I am no expert mechanic, but, I did read and follow the instructions that I stumbled onto in my new multi-function automotive digital test meter's owner's manual.)

The BAP sensor on FLM vehicles is a "solid state" \_frequency\_ output type device (as opposed to a voltage output device). The sensor sends a signal to the computer that varies with changes in barometric/atmospheric pressure detected through the open port on the XR's sensor. You can monitor this frequency output signal in 2 ways; by using an oscilloscope, or by using the "tach" function on a digital automotive test meter. (I have a "Sunpro Actron III" meter that I bought from a pawn shop for \$40.00.) You can turn the tach function into a frequency counter by some simple meter hook-up methods, as detailed in my meter's owner's manual. At 0 in. of vacuum applied to the BAP port, the meter reads ~ 4770 rpm, on the 4 cyl. setting, for all FLM sensors. The sensor output frequency (RPM) should decrease as you apply increased vacuum (using your hand vacuum pump). If the frequency (RPM) reading does not decrease with increase in applied vacuum, the BAP is bad. My BAP's output did not change at all, even when I took it to 15 PSI vacuum. Diagnosis, bad BAP!!

Given the hostile physical mounting location of the somewhat delicate solid-state type BAP on the XR (close to turbo heat and battery acid fumes), it's no wonder that they fail.

If you don't have a tach, and can't borrow one, then you obviously can't perform this "test". However, you can do what I did, once I determined my BAP was bad; I went to the local u-pull-it and removed one from a late '80's Ford (don't exactly remember the model, but I found that all the FLM cars in the row of cars that I was in had the same BAP on them, p.n. E3ZF-12A644-B1A, same wiring connector, etc.). Cost \$1.00. I put the used unit on my XR, performed the above test, and the frequency (RPM) output DID vary with different applied vacuum levels!! Problem fixed, for \$1.00!! (New unit from Ford was approx. \$75.00, if I remember correctly.)

I now have all 11's on both KOEO and KOER tests! My gas mileage went up from ~ 18 mpg, to ~ 23 mpg. Hope this helps. Again, I am just an amateur "mechanic", and obviously, each and every "disclaimer" that you have ever heard of in your entire life applies to this information!! (I hope there is an "Archives" for this post to wind up in!)

Regards,

**A2:** Just a short addendum to Larry Biles' very nice post:

Many "multimeters" have a frequency function. A quick check of your barometric BAP sensor can be done using a multimeter with a frequency function.

1. Connect the ground (-) lead of the multimeter to chassis ground or to the battery neg terminal.

2. Turn the ignition switch to the ON position. Don't start the car.

3. I used a hat pin clipped onto the end of the multimeter (+) lead, and pushed the point of the pin into the green/black wire enough to make contact.

4. I got a reading of 159 Hz. I tested the car at about 100' above sea level. This is about the correct reading for this altitude. Allan Slocum's book (and other sources) gives the relation between Hz and altitude.

I did not try varying the pressure on the BAP, but this could be done using the multimeter, and following Larry's procedure.

Summary: You can check the BAP without any disassembly or removing the connector, and without any special tools, using any multimeter which has a frequency function.

**A3:** This post is in response to the several people who have asked me to elaborate on exactly how I used my digital bench-type tachometer, and my hand-held vacuum pump, to diagnose that I had a malfunctioning/ inoperative Barometric Air Pressure (BAP) sensor.

(Brief "thread" history that was/is? in Archives; got car 5/99, great compression and leak-down test results, but was running SUPER rich at that time, had ONLY a code "42" on KOER, began to trouble-shoot cause, over time found and replaced bad ECT, PCV valve, BCS, TPS, ICS, clogged EGR, one leaky injector, and an original "petrified" lower-intake-to-head gasket that was the source of a major vacuum leak. Also. installed new NGK's, plug wires, etc. Each of these individual repairs incrementally improved the "rich" condition symptoms, i.e., strong gas-fume smell, low mpg, plug sooting, etc. Reached point where car ran pretty "strong", had attained ~18 mpg, but engine still wanted to lay-down a little at top end, and I STILL had a computer code "42"! Okay, now you're up to speed.)

The only thing I could think of left to check was the BAP, even though I wasn't getting a code "22" (indicative of a bad BAP). But I knew that the BAP sensor "reported" changes in barometric pressure/altitude to the ECA, and that the primary systems affected by the BAP sensor output were air/fuel ratio and EGR flow, and even if I didn't have a "failure" code "22", I felt I had to check it out. However, the service literature said you MUST have the special Ford MAP/BAP Tester to properly check out this sensor. ARRGGH!! Then I stumbled on to another method to check out the sensor, using my digital tach and hand vacuum pump (reference aforementioned post of 3/30).

NOTE: Per Bill's referenced post, any "tach" should work, and there are, no doubt, other methods to test a BAP; this method is only presented as the way I did it. I do not profess to have either special technical, or mechanical, expertise, other than the ability to "read and follow directions". (Requisite "disclaimer".)

Sure enough, when using this alternate "test method", the BAP proved to be "non-functional". I replaced it with a \$1.00 "junk yard" unit, and the rest is "history". (Again, reference my 3/30 post.) I do not know why the computer wasn't reporting the expected code "22"; maybe the "real mechanics" among you could explain that.

The following "alternate" FORD BAP test procedure that I used is quoted directly from the owner's manual for my SunPro Actron III Digital Automotive Multi-Function Test Meter:

- 1.) Disconnect wiring harness (and vacuum line, if so equipped) from BAP sensor.
- 2.) Connect jumper wire between pin "A" (blk-wht "ground" wire) on wiring harness and matching sensor pin-receptacle.
- 3.) Connect another jumper wire between pin C (org-wht "vref" wire) on wiring harness and matching sensor pin-receptacle.
- 4.) Connect RED meter test lead to sensor middle pin B (grn-blk "sig" wire).
- 5.) Connect BLACK meter test lead to good vehicle ground.
- 6.) Make sure meter test leads and jumper wires are not touching each other.
- 7.) Connect a hand held vacuum pump to vacuum port on BAP sensor.

(ATTN: The next step is VERY IMPORTANT!!!)

- 8.) Turn ignition key on, BUT DO NOT START ENGINE !!!
- 9.) Set meter rotary switch to 4 cylinder, "high tach" position.
- 10.) View reading on meter display:

For Ford "Frequency-Type" Sensor:

- a.) Verify hand held vacuum pump is at 0 in. of vacuum.
- b.) Display reading should be approximately 4770 RPM, +/- 5%.
  - 11.) Operate sensor:
    - a.) Slowly apply vacuum to BAP sensor.
    - b.) Display reading should DECREASE in RPM as vacuum is increased.
    - c.) Refer to specific vehicle service manual for charts relating frequency (RPM) drop to vacuum increase.
  - 12.) Test Results, Good Sensor:



- a.) Sensor output frequency (RPM) is within manufacturer's specs. at 0 in. of vacuum.
- b.) Sensor output frequency (RPM) decreases with increasing vacuum.

- 
- How to remove sensor connectors without damaging them sensor troubleshooting by Don  
How to disconnect all the plastic connectors without breaking them:

**The plastic connector plugs come in three types:**

1. Some are locking type and the locking tabs need to be pulled up before the plug can be removed. These are the most difficult so take your time and be creative.
2. Most are ramped slider connectors and the tabs open automatically by pulling straight apart or out. These are the easiest and a little lube does help.
3. Some are squeeze type and the tabs need to be squeezed before being pulled to be released. These are easy but most people break them because it is not easy to see how the connector works.

Type 1:

O2 Sensor: This takes two people and two small screwdrivers (or anything you find that works) to hold the locking tabs up while pulling apart.

Type 2:

ECT: Pull straight up on the connector.

VAM: Pull straight out on the connector.

Fuel Injectors: Pull straight out on the connector.

TPS: Pull straight out on the connector.

Knock Sensor: Pull straight out on the connector.

Fuel Injector harness, (power supply) Pull straight out on the connector.

Fog lights: Pull straight out on the connector.

Boost controller: Pull straight out on the connector.

Radiator Fans Power supply: Pull straight apart on the connector.

Fuel pump: Pull straight out on the connector.

Type 3:

Radiator Fan Switch: Push down on the connector tab and pull the connector off.

Headlight plugs: Push down on the connector tabs and pull back.

Brake Sensor plugs: Squeeze the connector to remove.

Coolant level sensor: Squeeze the connector to remove.

## Sound System (stereo, antenna, speakers)

---

- Aftermarket Antenna Source by Dennis Edwards

I Just installed a power antenna in my 86 XR this weekend. Purchased a European spec model (44-PW530) from AutoZone for \$53.99. They had to special order it, but received it within 3 days. This new one from AutoZone even allowed me to use the original support bracket on the bottom. The antenna that failed was a generic model I got from one of the part houses & had to adapt support brackets to when I installed it back in 1998. It's worth noting that while attempting to save money with these units, the original factory unit lasted 10+ years. I've got \$105.00 invested in these 2 antennae, with 3 years service & counting. There is something to be said for factory original parts.

---

- Welding the Antenna Cable ? by Glen Klein

**Q:** Has anyone found a source for the nylon cable that actuates the telescopic section or any other way of repairing or replacing a failed aerial? I recall a discussion on this subject several years back but no details. Bill in Boulder

**A:** Bill - I've repaired two now! I tore the antenna apart, clamped the two ends of the cable, lit up my propane torch and fused the two broken ends together! So far, so good... I tried a couple types of glue - no worky! The torch worked really nice... you just have to file the "boil-over" plastic off when it cools.

---

- Harada Aftermarket Antenna Source by Jon Lofquist

**Q:** My factory antenna finally took a dive on my 86 xr...

**A:** I've used a Harada MXB-22 power antenna. It fits great and looks better than the original. I had to open up the hole in the fender ever so slightly. Connector has a different thread pitch, but went on plenty far to make good contact. A very good quality product for only about \$50. The MXB-22 is black, the MX-22 is chrome.

**A2:** Audi antennas have the same style. In fact, the whole antenna will work.

Ian Glyn-Jones

---

- How to repair failed rear antenna on XR by Lih-Yen

If the Scorpio antenna setup is the same as 88+ XR4's (integrated into the hatch defogger grids), then my experiences may be of some relevance. The following are potential faults:

If the hatch defogger is working, check this:

1. the exposed section of the coax cable between the hatch and the rear roof, this may be broken due to repeated flexing, or more likely having been severed. Pull the rubber bellows boot to check.

Or this, especially if the rear defogger does not work:

2. inside the hatch there is an isolator box which filters out the 12V that heats the grid (I guess.) The coax cable connection maybe corroded or not seated well. Or, some of the high current traces/connections on/to the PCB may have been damaged.

You can repair the broken coax cable, and the repair can be done at different levels. The easiest is simply to pull enough length of the cable out of the hatch, pull out the leads from both ends of the break, solder them together, tape the sheath at the solder joints first with electrical tape then with HD duct tape, push the extra length back into the hatch, and you are done. Be careful with handling the rubber bellows boot. If broken, you may be able to replace it with a used spark plug boot, according to one ancient list member.

Note the cable core is some sort of very thin spiral coil, which is chosen specifically to deal with repetitive flexing, and is thus easy to stretch for repair.



More thorough repair requires harvesting a 'donation' section of the OEM spiral core cable from the part in the hatch (which is easier, or from the cabin, your choice.) Splice this harvested section in at the breakage so this repair (exposed) cable section provides an undamaged sheath. You then replace the sacrificed section by grafting in regular hard core coax cable and it's Ok because it is not subject to flexing.) You would want to have the repair section long enough so you can tape the cable down securely on the roof and the hatch to provide strain relief for the solder joints. Same taping and rubber boot handling recommendation as the simple repair. As for the defogger isolator box repair, it wasn't that tough either. Procedure here is from memory but basically that was what I did. Remove the box, you may notice burn marks in the PC board, badly corroded/burned spade connector, etc. In my case, the spade connector was completely broken off of the circuit board, and some copper traces were separated from the PCB. No sweat, just make sure that your repair will replicate the traces (simple circuitry to follow.)

For the bad traces I replaced them by jumpering with strands from some decent gauge wires, and completely saturated the strands with solder to prevent future corrosion. For spade connector, I soldered a 12 gauge lead to a new spade, heat-shrink wrapped it partially, and soldered the lead back to the board. Whatever you do, make sure you don't create potential shorts. Finally I had to cut a small bit off the plastic cover because the height of the soldered joints. I reinstalled the isolator box, and voila, I not only got radio reception but also the defogger function back. (It was still too late because the PO had already drilled a hole into the front fender to mount a mast antenna;-< )

Neither of these repair took longer than an hour, given that I have rather clumsy dexterity.

The '88 XR had the broken cable problem around 110k miles about 6 yrs ago, and was fixed with the simple method. Now it has 230k+ but the radio reception is still very good, and better than the 89' XR (118k) which had the isolator box problem. The rubber mask antenna the '89 has simply is not as good as the OEM defogger grid.

Hope this helps. I hate drilling body panels, and believe the OEM hidden antenna setup is an optimized one.

- 
- Radio & Amp Repair solutions by Roger Jones  
I thought I would put together a "solutions document" for the care and repair of the XR and Scorpio Sound System, so here goes. This is based on the separate Amp / Amplifier and Radio configuration.

#### Common Replacement Lamp, Light, Bulb for Radio Display and Amp Illumination:

Sylvania or Wagner 74 (seems correct & actually found in my Radio) Subminiature Wedge style base, 0.10 Watt, 0.70 Candle Power, 500 hours Avg. Life

Sylvania or Wagner 37 (suggested by F/L/M/ dealer) Subminiature Wedge style base, 0.09 Watt, 0.50 Candle Power, 2500 hours Avg. Life

#### O.E.M. Lamp Numbers:

Amp.: D4AB-13465-AA  
Radio: E6DF-13465-BA

#### Common Replacement Drive Belt, Cassette Mechanism:

PRB (Projector-Recorder Belt Corp.); part number SCX 12.1  
a.k.a. <http://russellind.com/EVG/main.htm>, part number 1425-85  
(Square Belt; inside circumference 12.100", thickness 0.108")

#### O.E.M. Belt Number:

Service Part Number B-10-16

Common Replacement Fuse (Glass, 5x20 mm):

Amp.: Fast-Blow 10.0 Amp

Radio: Fast-Blow 3.15 Amp

O.E.M. Fuse Numbers:

Amp.: E6RF-19003-AA

Radio: 82GB-19003-BA

## Steering

---

- Source for Power Steering High Pressure Hose by Charles Akins

Hi Don, I got one from autopartsgiant.com for 30 bucks in April. Nice piece, formed correctly.

---

- Should I rebuild the Power Steering pump ? by Bill Fye

I got my PS pump from AutoZone for somewhere around \$30. They loaned me the pulley puller for free, too. Its hard to justify rebuilding one yourself when they are so cheap.

---

- Power Steering Fixes by Lih-Yen Hsieh

Repair/replace? XR4Ti PS fluid tube leak

I found an abrasion leak in one of the fluid tubes that go from the gear port to the rack. This is caused by the clutch cable rubbing on the tubing, which surprised me a bit because

- 1) I thought these fluid tubes are steel (but no, it looks like aluminum); and
- 2) The clutch cable is routed so close to these tubes.

But, hey, my car has logged over 216k miles.

Has anyone come across this situation? Is repairing the tubing possible? Or do I have to replace it? If so, where can I get the part?

The reason I thought of repairing is I had a similar abrasion leak in a transmission line (in a Volvo) and the transmission shop was able to cut out the bad section and 'spliced' it up. But that was a steel tube.

Additional note: As a temporary measure, I fashioned a hanger from coat hanger to support the culprit, the clutch cable. One end hitches on a hole in the engine case and the other is a loop through which the cable went. It was so effective that 1: it lived up to the task, and 2. the purpose was so obvious that recently when I had the clutch and cable replaced the shop dutifully kept the setup (but probably wondered why 'Ford' had such a kludgy thing.)

---

- Separating the steering flex shaft coupling by Lih-Yen Hsieh

**Q:** I can't separate the steering flex shaft coupling from the gear after removing the pinch bolt. I also used a stubby flat blade screwdriver as the 'key' to enlarge the pincher opening. Are special tools needed, or are there other means to accomplish this?

By the way, I have an abrasion leak in the PS fluid feed line to the passenger side of the rack. I bought lengths of 1/4" (closest to the 6mm I measured) tubing, got flaring kit, tube bender, O-ring, etc. I found I really need to unbolt the rack from the cross member to get access to the fluid line flare nut at the gear port. I hope I am doing the right thing.

**A:** I got a suggestion to soak the splined joint with liquid wrench, which I gladly followed. I also unbolted the drive side steering rack retaining bolt. About 15 minutes later, I was able to simply slide the rack forward, separating the gear from the flex coupling. Thanks!

It was infinitely much easier to remove the power and return lines from the gear first then to remove the fluid feed line.

I have an abrasion leak in the PS fluid feed line...

I thought I could fabricate a feed line by flaring the ends of tubing stock, bending, and reusing the original flare nuts. But it doesn't seem very easy once the tubing assembly came off for close inspection. I also found the tubing is made of steel. This lends itself easier to be spot-welded for repair.

The difficulties are due to two things: the rather complicated flaring pattern and a nylon/plastic insert at the gear end. There is a compression ring like barb away from the regular single flare at

the end, together they form a groove in which the 5mm ID O-ring rides. The nylon insert could be a flow restrictor, I think.

For quick fix I am going to have the broken line welded, but I am not giving up playing with the tubing assembly fabrication.

Rough ascii drawing: left half cross section. 'O' is the O-ring.



Lih-Yen

If there isn't a great lot of pressure exerted in the line, you might fix it yourself with some sand paper, sheetmetal, and some JB Weld or similar cold weld. [...] cured. JB weld is good stuff-- I used it to fix the OE radiator in my '85

What Mark talked about is the power steering fluid feed line that has a leak. The PS pump has a pressure relieve valve that opens at a very high pressure, 750 psi. or so I think. Even after flow restriction these lines still carry lots more pressure than a radiator. Just remember that this is a hydraulic line.

I removed the line from the rack, took it to a welder and had the leak braze-repaired. If the welder knows the trade he/she should set the power very low. The cost is almost nothing for that (my friendly welder did it for free.) You must use new O-rings for the end fittings, and a lot of elbow grease is to be expected.

The most time consuming part is to remove the line. You need to unbolt the rack, and separate the flex joint coupler to gain access to the gear port. You than need to disconnect the power and return lines from the gear before you can loosen the flare nut of the line at the port. The other end (on the rack) is easy. Take note on how the line is threaded to help with assembling. Use flare nut wrench. Keep the whole thing really clean. Plug up any hole that may be exposed. Blow clean the tube before assembling.

Before you put it back investigate what caused the pinhole and correct it. In my case, one, there'd been PS return hose leak coating the whole area with a mixture of fluid and sand, and two, the motor mounts sagged so much the abrasive compound coated clutch cable sheathing hung down far enough and actually abraded up a hole.

- Lucas Power Steering Fluid Additive by Various

**Q:** From Andy Robertson: Folks, As part of my restoration/rebuild I had my rack rebuilt locally and got a rebuild PS pump. It had an annoying little bump in it especially when cold. Seemed like a valve popping off in a very abrupt way.

Anyway after scaring the hell out of myself on an off ramp, I decided to try the Lucas additive as recommended by Dave Compton and others.

I drained out some fluid. Added 1 bottle. Pump was even noisier than ever for the first few minutes What have I done I thought in panic! But five minutes later the thing was quieter than ever. And after a few drives around the block that annoying bump was gone!

Great idea! Thanks for the advice

- 

Steve Savaria wrote:

For those having trouble finding Lucas products in your area, you can order on line:

<http://www.gimmelucas.com/>

- Rod in Spokane adds:  
NAPA has it and I don't think I have found anyone who says "it doesn't work". In fact, Lucas makes some very good products that are well worth the money. Try their injector cleaner, too. As usual, Dave C was right :)). Thanks Dave!!

---

- Flushing the Power Steering Fluid by John Baas and Alan Slocum

**From Alan:**

I checked the MerkurEncyclopedia.com and somehow I forgot to put in the most important article." How to make the steering last forever". Simple and cheap. Try this even if your rack is quite "sticky". It won't work if the rack is leaking. If the pump is making noise, replace the pump and try the steps below.

First the theory, the pump overheats the fluid, which then fails as a lubricant, causing the pump to wear putting particles in the fluid, which wreck the rack.

The solution is to overkill the problem. Get higher temperature fluid, filter and fluid COOLER. The best fluid that is easy to get is Mobil 1 ATF. Power steering filters are a little harder to find but several are out there. (try IPD, the VOLVO people) Use a cooler off the trans of an auto XR, PS cooler off a big 'ol Lincoln, or anything from the yards. Put the filter and cooler in the return line. The cooler fits nicely in the bumper in front of the tire.

After putting the parts on, there is 2 ways to flush the system: one cheap, fast, and tricky; the other not.

Method 1 is to fill the pump with Mobil 1 and put the return line in a 1 gal or so pan. Turn the steering wheel full lock. Start the motor and while your friend is turning the wheel lock to lock you are pouring fluid into the pump reservoir. Keep turning and pouring until a pint or so of CLEAN fluid comes out the return hose.

Method 2 is to fill the pump with Mobil 1, start the car and turn the wheel lock to lock. Fill the reservoir as required. Drive around the block both ways to turn the wheel some more. Use a "turkey baster" to suck out ALL the fluid from the reservoir and refill with more Mobil 1. Repeat until the fluid is clear. In a week or so check the fluid and if dirty at all, repeat until clean. After a few months repeat again.

For both methods, check fluid clarity every year and replace if dirty.

- **John Baas adds:**

On mine, I removed the return line off the reservoir, and plugged the end of the reservoir. I then placed the return line into an oil drain pan.

I pulled the coil wire off, so it wouldn't start, got in, put the pedal to the floor (to disable the injectors) and cranked the motor while turning the wheel back and forth. Then get out, refill the reservoir, and do it again, until the fluid comes out clean. You can do this by yourself, just keep an eye on the reservoir.

I bought a gallon of cheap ATF, ran that through, then put in the good Mobil 1 ATF at the end. No sense wasting Mobil 1 during the flush phase.

---

- Steering Wheel Removal by Bill Stobbe and Mohammed ElRouby

**Q:** Any tricks for removing my steering wheel? My cheezy puller needs threaded holes. (besides drilling and tapping holes, that is. :P) Thanks, Mike in Ottawa.

**A:** Mohamed ElRouby wrote:

Here's the tools and the trick:

Tools - 1/2 drive ratchet

1/2 drive extension  
22mm closed socket  
flat head screwdriver

Trick. Put the key to 'lock steering' position. (steering column now locked - note position of steering wheel turn) Remove the horn button w/ flat head screwdriver. Undo the 22mm nut. Now put key in running engine position (unlocked steering wheel). Pull or/and gently rock up and down on steering wheel towards you. It should come free.

Once out, lock steering wheel again. Bolt on new steering wheel and nut, very tight but not TOO tight in the same position you noted above. Unlock steering wheel key and place in horn button. Drive. If all ok, enjoy.

Done this at least a half dozen times. Mo

**A:** Bill Stobbe adds: Another piece just to make sure on clarity. Remove the center of the horn assembly, not the plastic. The plastic edge has keepers that break. Ask me how I know.... The middle with the horn emblem comes out with a slight prying.

---

- Power Steering Rack Replacement by Tony Vissoc

**Q:** Susan E. Hall Asks: My '88 XR needs a replacement steering rack and pump. Going to Autozone, Bat and Rapido gives me a variety of different prices. I understand that this will be a complete replacement of hoses, rack and pump.

**A:** You can get a decent remanufactured rack at Autozone. No need to pay more.

I am curious what year of XR you have. There were two different styles of racks put in them. They will both interchange and work fine. The main difference is in the number of steering wheel rotations it takes to turn the wheels from left lock to right lock. It is mainly a matter of "feel" preference. The way to tell the difference in the two racks is visual. The later style rack has a "waffle" type texture to the rack body. You can see this under the car. I'll see if I can find a picture that I can post.

For most, the later style rack is the most desirable. I've never driven another XR to form an opinion. If you have a preference, make sure to specify that you want the later ZF style rack.

Another thing to consider while working on the steering is front end bushings and related suspension components. They all play a part in how the car responds to your input. A twitchy, side-to-side feeling could also be a problem with alignment, caster, camber and control arm bushings. Have these things checked out and come back here for suggestions on bushing replacement.

**Q:** What have people done in the past successfully, and cost effectively! for this problem? This is a new car for me and we found the steering fluid to be full of metal, plus there is a kink in the turning motion of the car, so no doubts about replacing the whole thing.

**A:** If it is truly metal, and not rubber (probably a combination), you may want to look at replacing the pump too....

**Q:** How did this happen originally and how to avoid it in the future. Is this an XR issue that I should be looking into more carefully while I maintain the car?

**A:** Age, heat, etc. When the rubber in the power steering lines breaks down, the particles end up in the fluid. Metal will appear when the fluid doesn't perform its job properly for lubrication.

When you get your new rack in place, you will want to flush out all the old fluid. If you get a new pump, you'll have less work to do. If you don't replace the pump, you could disconnect the pump return and pressure lines and dump new fluid in the top. Rotate the pump by hand to push the fluid out. With everything hooked up, run the car for a few days and repeat the procedure until the fluid looks okydoky.

A good idea at this point is to install a filter in the return line to the pump.

---

- Power Steering Rack Replacement How-To by Tom Rhinesmith

**Q:** Any tips on replacing rack in an XR? I'm on my 3rd replacement from AutoZone. First one was actually broken. Unfortunately discovered this when I had it home and ready to replace the one I just removed! 2nd one turns with lots of resistance. In fact turning left has lots of notchiness.

Guess that's a word. Just got my 3rd rack and want to replace it with and have it work! What I've

done is replace the ps pump and added a filter and cooler. Any tips on how to install the rack. Am using synthetic Castrol fluid in the system. all help greatly appreciaed!

**A:** I don't know about those racks from Autozone, considering the problems you are having with them. Advance Auto isn't much good either. I don't even think they are capable of supplying the right rack. Be cautious of any rack coming from (?) Carbone (?) company. They are junk. I got mine from NAPA with a lifetime warranty. It was a Beck Arnley product. Expensive, about \$400.00 plus, plus shipping.

I offer this solely from memory, so here goes.

1. Loosen lock nuts for outer tie rod ends. Pay attention to the number of threads showing since you will be threading your old tie rod ends onto the new rack's tie rods.
2. Remove cotter pins from tie rod end castellated nuts.
2. Remove nuts.
3. Replace nuts upside down, and leave flush or slightly above spindle to which they thread.
4. Gently tap with ball peen hammer or similar until tie rod end releases from wheel spindle/control arm assembly. You should not need to use a ball joint removing "fork" to release them. I never have had to use one on these cars.  
*\*\*\*\*Another option is to loosen the nuts and just back them off until you have maybe 1/4" gap on the threads. Then take two hammers (5# hammers work well) and simultaneously whack opposite sides of the spindle assembly where the rod end conical part passes through. One or two whacks and they will pop loose. Then totally remove the nut and continue.*
5. Remove air dam support bracket (four or five hex headed bolts)
6. Using screwdriver, remove machine screws which secure the metal "radiator" lines to the rack. These are merely screws for the rubber dampers which insulate the lines from the rack body. There are only two, & many times are difficult to remove due to rust/corrosion in the head of the screw. These are very unique in their thread design, and the only other place on the car with similar threading are the ones securing either the Cyclops brake light or the ones holding the license plate bulb assemblies. I don't recall which.
7. Using a small (size?) socket, remove the bolt which holds the power fluid lines to the rack. This is a real mother of a task. There is very little room to get the socket on the head of the retainer bolt, and the angle is very, very awkward. You will be lucky if you get a quarter of a turn at a time. This is the worst part of the job. After the bolt is removed, pull the assembly from the rack. There are O-rings for each line which must be released from their seats.
8. Loosen (*\*actually remove*) the pinch bolt which holds the steering wheel linkage (the U-joint assembly with rag wheel) to the rack yoke. Make sure it is loose. Pry the slot of pinch bolt receiver with a large flat screwdriver to ensure it will easily slide free from the yoke spindle.
9. With deep socket and breaker bar or ratchet and cheater extension, remove the two large bolts from either side of the rack; these are the only things securing the rack to the frame.
10. Pull the rack forwards and downwards to remove from its resting point on cross member. (Remember that pinch bolt for the steering wheel linkage!)
11. Center new rack's spindle by finding center point (mid point between left "lock" position and right "lock" position (The new rack should come with instructions regarding this).
12. Place tie rod ends on either end of the new rack's tie rods, trying as best possible to approximate the number of turns used to remove them from the old rack. You want to be as close as possible so you have some semblance of "alignment" so you can drive it to the front end alignment shop.
13. Place rack back up on cross member, of course remembering to start the pinch bolt receiving assembly back onto the rack's yoke spindle before getting her up and in.
14. As usual, the rest of assembly is the reverse of disassembly.
15. After everything is installed and reattached, fill power steering pump reservoir and prime rack by turning steering fully to left and right several times.
16. Get her to the alignment shop as soon as you can.

Note: Others on the list can give you advice on how to do a provisional realignment that will get you straightened out enough so as not to destroy your rubber on the way to the shop. (see next post)



---

Front End Wheel Alignment by Steven Roberts

Here's what I do, and for me it's the final toe-in adjustment, not provisional.

The tools:

- Two bricks
- Two 1x2's each about 2 ft long.
- A tape measure.
- And a helper.

Preparation:

I roll the car back and forth a few times on a level pad 5-6 ft each way.

I set the bricks up against the front tires on the outside, and place the 1x2's on top of the bricks. This brings the 1x2's about as high as possible and still being able to stretch the tape measure between the 1x2's under the car.

Ready to measure:

I have the helper hold the tape measure at one 1x2 at the front of the tire at a distance about equal to the diameter of the tire. I do the same at my tire. I read the distance off the tape measure. Then we move to the rear of the tire and do the same. The difference between the two readings is the toe-in (or out). Now, adjust the toe as needed. Re-measure.

This has always worked well for me, and doesn't involve a laser or any other sort of sophisticated equipment. It's not rocket science and seems to work pretty darn well, at least for me.

And, finally (really!), I've used the Autozone \$130 rack, and it seems fine. It's the ZF one. You can choose which one you want. I don't know how many rebuilders there are, but I would bet there's maybe one or two. I'm not sure that Beck/Arnley (or any other parts suppliers) does their own. I think they just buy what they need on the "spot" market, as available. I could be way wrong on this however; it's just my guess.

---

- Front End Alignment by Dan

Used to own a front end shop. Most will agree that the best way to set toe-in is direct measurement, in that there is less chance of error.

With the front end jacked up, spin each tire fast and using a light color quick dry spray paint, spray a 1/4" stripe around the circumference of the tire. With the paint still wet, spin the tire again and use a nail or screwdriver blade to scribe a line in the paint. A jackstand is a good tool rest to keep the scribe stationary.

When the paint is dry, lower the car and push it back and forth about 3' to settle the suspension. With a buddy, measure between the lines on the back of the tires and then take the same measurement at the front. I set my XR with 1/16" toe in, because the rack and tie rods are in front of the ball joints. If you set toe on a car with the steering in back of the ball joints, set it for 1/8," because the wheels will tend to toe out more with speed. Likewise, if the steering and ball joints are less than tight add a slight bit more toe in. There should be no toe in or out on the rear axle because there are no steering components to consider.

---

- Power Steering from Autozone by Steven Roberts

I recently replaced my '85 XR4Ti steering rack and steering pump. I ordered the parts from Autozone, which sells ATSCO. They had the cheapest pricing (not generally the best criterion, I know...). For the rack, I called ATSCO and they said they can supply either the ZF rack or the TRW rack. ATSCO calls the ZF rack the "Type 2" rack. The TRW is called "Type 1".

For example, the way to get the ZF rack from Autozone is to have the sales person phone ATSCO at the time you place the order. I had no problem getting them to do this. The Autozone sales person should tell ATSCO they want the Type 2 ZF rack. ATSCO will then link the order and the rack type to the PO# which Autozone also supplies.

ZF Rack: ATSCO p/n 6441 Type 2 \$139.99 + \$90 core  
TRW Rack: ATSCO p/n 6441 Type 1 \$139.99 + \$90 core

Pwr Str Pump with Reservoir: ATSCO p/n 6199 \$35.99 + \$10 core  
Pwr Str Pump without Reservoir: ATSCO p/n 6258 \$30.99 + \$10 core

I've installed these parts, but have not yet driven the car. I'll post my experience regarding operation, noise, leaking, and so on.

---

- Boiling power Steering Fluid by Charles Akins  
The PS fluid boiling. I had this happen on a rack that I cleaned up from a parts car and put on the MadCow project. When I first started the car, it took about 1 minute for the PS reservoir cap to blow off with boiling hot fluid shooting up 20 feet in the air.

This was diagnosed as a faulty "bypass" valve in the rack. This valve is activated open when there is no movement from the steering wheel, allowing the fluid to circulate from the pump around the power circuit. With this valve stuck closed, the pump compresses, compresses, compresses against a closed door, causing the temperature of the fluid to increase rapidly.

I found a great source for pumps and racks through AutoZone. The rebuilder is ATSCO in Phoenix. The rack was \$150 plus tax. Lifetime warranty. The most amazing thing, was the customer service at ATSCO. The AutoZone guys gave me the contact number. To make sure I got a ZF instead of a TRW, they physically walked my order through to the warehouse, and the rack arrived overnight to Escondido, Ca. They also CALLED ME (I had asked them to) after inspecting my core rack to tell me about it's condition and failure mode. They had also offered to receive and rebuild MY core as an option.

As far as the Lucas goo products go, I'm a firm believer in running the lubrication in viscosities and composition as recommended by the manufacturer. No "suspended Teflon balls", "stranded silicone filaments", "melaluca snake oil", or "cream rinse conditioners".

I run ATF "F" in my PS systems. Straight up. It's cheap, it's specified, it's a pretty red color..... when the color gets darker, change it, and keep fresh rubber hoses in the circuit. The hoses chemically react with the hot fluid over time, deteriorate from the inside out, and gum up the works in there. According to the ATSCO guy, the largest cause of PS system failures. Renewing the rack should automatically include ALL NEW HOSES. Spend the extra 40 bucks on the rubber and flush, flush, flush.

---

- Rack and Pinion Leak and more by Bill Fye  
**Q:** I was told today that my rack and pinion was leaking (something definitely was - I thought it was oil) and needed to be re-built. The estimate came to \$790. The car drives fine, no play-shimmy-vibration whatsoever in the steering wheel. Goes straight down the road. I haven't located the leak yet, but it seems strange that a re-build would be necessary just to fix a leak. I haven't searched archives yet - I'm still at work. But, if anyone has any ideas on common causes for R and P leaks, I would appreciate a response. TIA! Hank Wegener in Indy  
**A:** Check the hoses first. My return hose was all split and leaking like crazy, also, there are o-rings that can deteriorate on the hoses with fittings. Both at the rack and at the pump. My o-ring was leaking at the pump You can find new ones at any place that carries o-rings (auto parts stores) just take in the old ones and match them up. If you are leaking at the rack (not the o-rings on the hoses) You need to replace the rack. Autozone sells them real cheap (like \$129?). Be sure to specify that you want the ZF rack, or you will end up with the old style TRW and lose a lot of steering precision. They will need to special order it and you will pay a core charge or take your old one in for exchange. Double check it to make sure it has a waffle-pattern on the housing (ZF Style) before you start taking your car apart. Also, you will need to put mounting bushings in the new rack, so order some new ones from Rapido or BAT and take them somewhere to be pressed in. Also, be mindful of the position of your steering wheel when you put things back together

again, so it will point straight once you are finished putting it all back together. I bought a rebuilt pump at the same time I bought the rack. The pump was under \$30. The job of replacing the rack and pump is a straightforward remove and replace operation. You ought to find out what the book rate is to have your mechanic do it with your parts and weigh whether it would be worth it for you to tackle yourself. Good luck. Bill Fye'88 XR4ti

---

- Front End vibration due to overtorqued wheels by Jake

Just thought I'd let everyone know my recent experience. For the past several months I have been experiencing a significant vibration in the front end of my XR. I checked every bushing, including the nylon bushings where the sway bar meets the control arm. I could not find the source. The wheels had recently been balanced, so I felt I could rule them out. Anyway Saturday I finally checked the lug nuts. They were all waaayyy too tight! One of the nuts on the right side was so tight the impact wrench couldn't break it! I had to use a breaker bar and a 4' pipe to loosen it.

I re-torqued to the correct spec (75-100 ft/lbs) and viola! The vibration is all but gone. It seems much, much smoother now. It seems the kid at NTB (I say kid, but he was probably my age) had just run the nuts on as tight as possible and that pulled the front hubs out of round. Anyway I was glad when everything seemed to return to normal after I re-torqued the lugs.

---

- (Shaking Wheel) Balancing the wheels on the Scorpio by Dan

In a past life I owned a quality suspension shop. After establishing the business, we specialized in exotics; Italian heavy contenders, Porsches, AC Cobras and formula cars.

To my experience, a shaking steering wheel is caused by one of three things; bad wheel balance, bad wheel balance and bad wheel balance. Don't get me wrong, a shake will be exacerbated by other factors like loose suspension components, out of round tires and bent rims, but unless there is imbalance, it wont shake.

The first thing to do is to drive the car for about 10 minutes to warm the tires and then immediately jack all four wheels off of the ground and support the vehicle by frame components. Spin all 4 wheels by hand and carefully look for irregularities such as out of round tires or bent rims. Any snaking or wobbling of the tread is suspicious for a tire separation. If any of this exists, correct it first. A 1/8" out of round tire is all that can be tolerated in these cars.

After evaluating the tires and wheels, check the front end by extending both arms and pushing out on the front of the tires. Looseness in the ball joints, tie rods and other components will be noticeable. Take a good look at the outer sway bar bushings by pushing on each front tire fore and aft. Almost all of them are worn out. Replace them with Poly which will give you a slightly firmer ride, but in Merkurs, these bushings are the only component that keep the wheels from going north and south and rubber bushings at this location are for pussies. Again, if anything is broke, fix it.

If your car passes all of the above, get at least the front wheels rebalanced. Beware! Not all shops and balance equipment are equal. If you don't believe this, get the rear wheels balanced and then jack up one rear supported by the frame. Open the door on that side and put the window 1/2 way down. Put it in 4th or drive and run the speedo up to 50. My money is that the window will shake and you will feel vibration in the seat. Don't do this if you have any sort of posi or limited slip, in that case you will have to jack both wheels and run it up to 100.

The best way to find a quality wheel balance shop is to get a hold of a Porsche Club of America member and ask. These guys know because the 911 is hypersensitive to wheel balance and the owners are hypersensitive to vibration. You will have hit paydirt if you find a shop that does on the car balance by hand. If the wheel is run up after weights are put on you can see any remaining shake in the window glass and you can feel it in the steering wheel or in the stationary wheel on the other side, usually at about 55mph. A little trial and error with moving the weights usually removes 99%. Most of the guys that know this have retired. I still do all 4 wheels by hand after the shop has used the great looking machine and my XR is the only one I have driven that is 100% shake free at the steering wheel.

I know that all of this may sound like overkill to some, but these cars are famous for shaking. This is true for the entire lineage from the Ford Cortina to the Capri and to our Merkurs.

---

- DIY Steering Rack Rebuild

**Q:** I Got a couple leaky racks that are otherwise good. Are the seals available, and how hard are they to install? I know I can get a rebuilt unit at Autozone or I could have mine rebuilt. I'm handy. I like tools. I dig grease. ATF makes a good cologne. Old motor oil makes a good hair dye, etc.

**A:** The thing that kills racks is the 3-4 teflon seals in the servo housing which wear the aluminum housing to the point fluid leaks around and eventually out, and unless you can deal with grooves worn on the ID of the housing, you are miles ahead with a warranted rack.

## Suspension

---

- Source for KYB struts for XR by John Baas and Simon Matthews

**Q:** In the past I've gotten KYB front struts for my XRs from both Summit Racing and my local NAPA store. Yesterday, they were neither in stock nor "available" from either source. Calls to several other local auto parts stores turned up no one who sells KYBs. Hmm. I see them listed in BAT's catalog for ~\$99 each... Anyone know of a source with pricing closer to the ~\$69 to ~\$75 each that I've paid in the past? – John Welsh

**A:** I got mine from PST, <http://www.p-s-t.com/> Should be able to get the whole set (front and rear) for \$189

**A:** I got mine from <http://www.shox.com> quick response, fast shipping great prices.

---

- Strut Tower Bearing by David Compton

**Q:** Does anybody know where I can find a new right front strut tower bearing for a 1988 XR4Ti?

**A:** Order the repair kit part number AD-234 from any Motorcraft or Ford dealer. The price is incredibly low. The kit includes new upper rubber mounts, the bearing and a new strut nut.

**(ED.- Now discontinued)**

---

- Swapping over Scorpio suspension for XR by Brad Anesi

**Q:** Does anyone know if the Scorpio hubs/rotors/spindle will fit an XR in the front? What about the rear? I'm probably going to pick up an XR in a few days and want to re-drill it for some 5 lug wheels. It seems like it would be better to offset drill an existing 5 lug part than a 4 lug part. And I didn't really want to get into welding up old holes. Scorps are disc in the rear though, right? If it came down to it I imagine I could swap over the whole damn trailing arm? Thanks, Scott Shidel

**A:** I'm not sure about the fronts, but I believe they are swap-able. The rears are most definitely swap-able, but you NEED to swap the whole control arm because the hub center is larger on the Scorpio. But you get a couple bonuses going this way --> you'll get disc brakes, a stronger shock mount, and the ability to easily use the bigger Scorpio anti-sway bar which mounts inboard on the arms. I think the Scorpio arms are actually shared with the Cossie. One thing to think about though... The Scorpio 5-bolt pattern is a kinda odd-ball pattern, shared only with Mercedes and maybe something else, so you won't have a big wheel selection at all. Brad Anesi

**A:** Scott, if you've got a set of VW/Audi 5x112mm rims they can be made to work. But, you'll have to bore the centers out to fit the Merkur hubs. I tried my A6 rims on the Scorpio once and there was quite a size difference between the two hubs.

Front strut tubes are a different diameter (Scorpio vs. XR), so that may be a problem. And I think the Scorpio front springs are too large to fit in the XR's shock tower anyway.

You could just swap the rear bearing carrier you don't actually \*need\* the Scorpio rear arms, this would get you rear discs. The Cossie uses the same rear calipers, but 20mm larger discs.

Bearing carrier off a Cossie is different from a Scorpio. It sets the caliper 10mm farther out to clear the larger discs.

TTYL, Ric Gillis

**A:** The Scorpio hubs/rotors/spindle will fit an XR in the front and rear? The Scorpio uses longer front LCAs (Lower Control Arm) and you will need them. Basically it is the same swap as doing Cossie front suspension. You will gain track width and inboard wheel clearance. Also the front brakes and rotors are identical between XR and Scorpio (with the exception of the bolt pattern on the rotor). Scorpios are disc in the rear though, and you will have to swap the entire rear suspension, it's an all or nothing. You will have to use the diff mount from the XR, the Scorpio's has a wider bolt pattern.

As for wheel selection, the Scorpio has a 5x112 bolt pattern on a 63.4mm (same as XR) centerbore. Scorpio hubs have been successfully modified to 5x4.5 using off the shelf Cobra studs. Dimitri - NYC

**A:** I guess I messed up big time as I'm seeing everybody state that you will have to swap the entire rear suspension from the Scorpio yet when I installed the Rear Scorpio disc brakes on my car four years ago all I used was the bearings along with their housings the stub axle and the hub. I wanted to keep the four bolt pattern so we welded up a few holes and redrilled the hubs

and rotors did have too open the hole in the arm where the stub axle goes thru but very little was taken out. Regards, Larry Davis

- 
- Powerflex Rear Beam Mount Bushing install by Grayson and Tim Roman

**Q:** I just spent some time today attempting to install a pair of Powerflex rear beam mount bushings to my 86 XR. After I got the first bushing installed I discovered that the bushing mount bolt appears to be too short for the added height of this bushing. Try as I might I could not get the bushing compressed enough to allow the bolt to thread into the frame. Has anyone else had this problem? I installed a set on my Scorpio (XR should be the same, .ed.) some time go without any problem at all.

I ended up putting on a new set of GP-N bushings instead.(BTW, these Powerflex bushings go in a lot easier than they come out!) The "rubber" portion of the Powerflex bushing is almost one inch higher than the stock bushing configuration so without using a longer bolt I am not sure how these can fit.

They would also appear to hold the beam farther away from the frame. Isn't that going to change the camber of the rear wheels?

Thanks, Jim Wirt

**A:** Installing the beam with the Powerflex beam mount bushes is not a walk in the park. It's flat out difficult. Here are some tips:

- 1.) Loosely install the diff mount to chassis bolts.
- 2.) Lift the front of the crossmember up to the chassis so that both beam mount bushes are in place. Basically, we want the beam to be level from side to side so that the angle of the bolt when pushed through the bushing is equal to the angle of the threaded hole in the chassis. This is very important.
- 3.) Push the metal cylinder that the bolt slips into at the center of the mount bushing up such that it sticks out of the top of the bushing by about a quarter-inch. The protruding cylinder will act as a dowel.
- 4.) Jam your socket with paper towels so that the head of the bolt barely enters the socket under extreme force. This is hard to explain, but what you are trying to do here is allow yourself to push up on the bolt with the socket. Pushing up on a bolt without paper towels in the socket will result in the bolt slipping further into the socket, whereas if the paper towels are in place in the socket, pushing up on the bolt will result in your pushing up on the bolt :-)

Your concern about camber changes is healthy, but unnecessary. Once you get that bolt torqued, you'll see that the bushing compresses A LOT. The installation of these bushings will not result in no alignment issues. Grayson mc<sup>2</sup>racing

**A2:** Tim Roman adds: The powerflex bushings are tough to get in. I ended up getting a longer bolt and then taking a tap to add some threads to it so that it would fully compress the powerflex bushing. The powerflex bushing look taller when you are putting them in, but you must tighten the bolt enough to compress the bushing until the metal tube that comes with the bushing is tight. The bushing gets squished out and the over all installed height is the same as the stock bushing.

**A3:** Terry Watson adds: I was prepared for the worst based on some of the posts and the archives. Whoever posted the note about using pieces of large diameter PVC pipe from the hardware store deserves a reward! I'll give a few details of how to do it here. What you need:

- One piece of PVC pipe about 1.5" long by 4.5 inches INNER diameter (search around the plumbing section and find a coupling with this ID and then hacksaw it off to the right length)
- One 1" pipe floor flange (this is actually about 4" in diameter with about a 1" hole in the middle of it)
- One piece of 1/2" dia. threaded rod about 8" to 10" long and a couple of nuts for it
- Two pieces of steel "U" channel about 6" long each (I got a 3 foot piece that measured 2" wide by about 3/4" high and hacked it up). Drill a 1/2" to 9/16" dia. hole in the center of each piece of channel. To make life real easy on yourself, weld on of the nuts in the "U" of the channel where you drilled the hole so the threaded rod can screw into it. If you can't or don't do this, try duct taping the nut in place so it will be easy to get the rod in from under the car.

The procedure:



Jack the back end of the car up and support the frame with jack stands. Put the jack under the end of the cross member on the side you want to replace the bushing. Raise the jack to apply pressure to the cross member. Remove the bushing bolt and the two guide plate bolts. Slowly lower the jack to lower the cross member. Find large a socket that will fit over the top of the old bushing (like a 7/8" or so). Put the socket down over the top of the old bushing, then put a piece of the channel on top of the socket ("U" up to protect the tube coming out of the car body where the large bushing bolt goes). Spray some WD-40 on the old rubber of the bushing and jack the cross member back up. The bushing will pop right out of the cross member. Honest! Lower the cross member and clean the area for the new bushing. Spray it with Armor All or another non-petroleum lubricant. Put the piece of PVC pipe on top of the cross member. Put the piece of the channel with the nut on top of the pipe ("U" up again). You may have to pry the cross member down some to get this stuff in. Thread the rod up into the channel & nut. Spray Armor All on the bushing & slide it on the rod. Next slide the 4" flange onto the rod, another piece of channel, and nut. Tighten the nut on the bottom end of the rod which will cause the flange to press the bushing into the cross member. The bushing will not "pop" in like it popped out, but will gradually creep into place. Loosen the nut and feel around the top of the bushing to make sure it is all the way in all around. If not, snug it up again real good and let it sit for a few minutes till it seats. Lower the jack, remove your homemade tools, raise the cross member and bolt it up. Lower the car & you're done!

BTW, the channel will nicely hold a box wrench or open-end wrench to keep the upper nut from turning while you tighten the lower nut.

This whole procedure took me about a half hour to do one side, after I had made the tools. The next day I started the Euro headlight conversion, which took the better part of two days & is the most masochistic thing I have ever done on the XR! Changing heater cores has to be easier! I really like the new headlights, but changing the cross member bushings is really a piece of cake compared to other things you might want to do. If you are contemplating changing out your bushings because you think it is too difficult, you just may want to reconsider it!

- Shimming the rear end to fix negative camber by Nick Larson and Don

**Q:** Hi all, I FINALLY got to drive my '86 XR for the first time yesterday. Short story, it's a cheap car I drug home and now that it's basically operational. It's got old, mismatched, dry rotted tires on it now. I figure I'll replace them. The problem is that it's got massive negative camber, especially in the rear. Where do I need to start? Is this a problem with sagging springs that could be remedied with an alignment? Is it a bushing problem in the rear? How do I assess and then fix the problem? I plan on doing it all myself. Alignment and all, so if anybody has any pointers, let me know.

**A:** My '87 XR had lots of negative camber on the rear, mostly I believe due to sagging springs. IMHO, my car looks good with the wheels where they are relative to the arches (side view), and the suspension does not bottom in reasonable use, so I have no interest on buying new springs. Your XR appears to have about the same amount of sag. I got a rear shim kit from Rapido. Kind of expensive for a bag of shims, but it did come with instructions. Short description of the technique is: shimming between the rear wheel bearing carrier and the trailing arm. Remove rear wheels & drums, loosen the 4 bolts that hold the rear wheel bearing carrier to the trailing arm. As you will see, the brake backing plate is sandwiched between those two. Shim behind the backing plate to suit. Button it back up, and see what you have. Repeat as often as you desire. I would do something more professional on a racecar, as it does side load the bolts a bit due to the shims, but mine have not come loose. I think I shimmed the top bolts equally, until the camber was about the same as the front wheels. At the time I had no manual or specs, so I just eyeballed it. Toe in & camber looked OK, so I ran with it. Some other Merkanic / Lister may have more specific info. I'll try to find the instructions, as well as the camber & toe in specs from my manual. I'll get the model of the Michelins I put on also. They are nearly as sticky as the set of Pirellis I put on initially, but have lasted more than twice as long ( 54k miles ), and there is more tread left!

**A2:** Ok, First check all the bushings. If the alignment shop didn't do that first, find another shop that has a clue. Then after you have replaced any bad parts you can shim the rear to make up the difference in the sagging springs. Get the car aligned so that you know what the degrees are so that you know what size shims to use. Here are the formulas:



-----  
Multiply the degrees that the camber is off by 2.1 inches. Find the SIN of that number.  
This is the amount, in inches of the shims that need to be installed to fix the camber.  
-----

Multiply the degrees that the toe is off by 3.6 inches. Find the SIN of that number. This is the amount, in inches of the shims that need to be installed to fix the toe.  
-----

Now in your example if the camber was off by 3.04 that would be  $3.04 \times 2.1 = 7.14 \times \text{SIN} = .0124$  inch shim. That is an extremely thin shim. I had to buy a pack of .005 shims to do my car and cut them to shape. Make sure when you get your alignment done that they know that you are going to come right back to have the alignment rechecked after you shim it. My local alignment shop will check the alignment for six months free. (They hate me, LOL.) You can read the rest of the directions for this at the Merkurencyclopedia.com. It is so simple to do once you have done it and once you find the shim stock. Try an industrial supply house in your area. That's where I got mine.

- 
- Stock front spring stiffness by Steve Monk and others

**Q:** What is the stock spring rates for the XR wheel springs ?

**A:** I have some detailed Ford sales literature for the XR4 from 1984. Under Specifications, they list the front spring rate as 97lb/in, and the rears at 257-502lb/in (variable).

**Q:** How about for a **coilover conversion**, what's good ?

**A1:** When I purchased my coilover kit, it came stock with 300 lb-in and it baffled me how they could be 300% higher rate then stock. The Lowest AVO would go is 250lb-in, so that is what I got. The car road much SOFTER then stock!!! I then read in a magazine article that the rouche XR's that were sold in the late 80's came with 325 lb-in, up from the FACTORY 280 lb-in. Now this made more sense. I have since put 325 lb-in springs in the front and I am very happy with them.

**A2:** I did a front coil over conversion and started with 250 lb/in and they were just as soft if not softer than the stock springs. I've got 350s now but I think I've over done it. I was thinking of backing off to 300s but maybe 325 would be better. Cheers James  
-----

- Hardness Comparison of replacement bushings by Chris Anglin

Hello all. As promised, I have durometer data on Powerflex and BAT polyurethane bushings, with the added bonus of some Group-N bushing info.

First, a durometer, to my understanding, measures the hardness or flexibility of a material. The durometer measures from 0 to 100, with 100 being the hardest, where the material allows no penetration of the probe and the material doesn't deflect from the pressure of the probe.

Second, the items measured weren't all the same as the other, but I measured them by averaging four measurements obtained on each bushing. Even though the items are different, the material itself is what is being measured.

The items measured were:

- BAT's Inner Track Control Arm (TCA) bushing (harder of the BAT polyurethane bushes), BAT#1
- BAT's TCA to swaybar bushing (softer of the BAT polyurethane bushes), BAT#2
- Powerflex swaybar to body bushing, P#1
- Grp-N upper strut insulator, GpN#1

**Here are the results (individual measurements, then the average):**

**BAT#1: 86 86 86 85 ave: 85.75**

**BAT#2: 84 84 79 84 ave: 82.75**

**P#1: 79 81 85 84 ave: 82.25**

**GpN#1: 67 81 77 84 ave: 77.25**

Summary: These numbers aren't an index of ride harshness, but they do provide some insight into how the ride may be affected by the bushings.

Note: I indicated that the BAT bushings seemed to be of different hardnesses. The Inner TCA bushing seemed harder and the TCA to swaybar bushing had a lot of the same feel and visual properties that the Powerflex bushing does. It almost appears as though the Powerflex bushings were molded or cast, and the BAT Inner TCA bushing was machined.

This appearance or assumed method of manufacture doesn't seem to relate specifically to hardness. For example, the bushings I have for the steering rack to crossmember mount, supposedly polyurethane, seem so hard that they are almost plastic. Caveat: Manufacturers may use different hardnesses of materials at different bushing points in one application depending on the demands of the environment. This may have an effect on my numbers.

Hope this provides some interesting reading,

- 
- Weight distribution in '86 Merkur XR4Ti by Clem Sparks  
I had occasion to scale my car at work the other day (since I had the rig set up for a customer. Total with no driver and 3/4 tank fuel (VERY approximate on the fuel): 2950lbs.  
With me in the car and the same fuel load, here are the corner weights (I'm about 175):

LF: 845          RF: 801  
LR: 779          RR: 699

The corner weights with me in the car look pretty good for a factory stock car in full trim. Just a little fact someone might find helpful.

- 
- Installing Front Outer Control Arm Bushings by ??  
I bought a set of Front Outer Control Arm Bushings (at the end of the Front Sway Bar). These are the more dense (poly?) type, kind of a hard, off-white/ tan color Bush with SIX small holes through them.  
**Q1:** When installing, how do you orient the holes? Toward the Wheel, the hub, up, down?  
**A1:** Don't worry about the vent holes in the bushings, they will work in any orientation. I put them down to aid in draining moisture.  
**Q2:** Should any part of these be greased to keep them silent?  
**A2:** These are not the bushings that need grease. It is the bar to frame bushings that sometimes squeak.  
**Q3:** I remember having a BEAST of a time getting the last set on. What's the best way to get these things on the car ?  
**A3:** For an easy installation, put the front of the car on jack stands supported by the frame. Remove the driver's side control arm inner bushing bolt (the one that goes through the cross member). This will relieve the preload on the bar and you can now replace the bushings on both sides. To get the inner bolt back in, pass a stout line (rope) through a wheel spoke and tie it around the wheel/tire. Use polypropylene or sisal rope (not stretchy rope like nylon). Put the knot and 3 o'clock and pass the other end of the line around the bar to frame bracket on the driver's side and tie it tightly. Put a helper in the car to apply the brakes to hold the wheel in position. By turning the steering wheel to the right, the helper will be easily able to add the preload to the bar and the inner bushing and bolt can be lined up and installed. Use a large hammer and pry bar to position the inner bushing and keep your fingers out of there!

## Transmission and Clutch

---

- Aftermarket clutches by Ian Glyn-Jones The XR Connection Ontario , Canada  
Find a dealer for LUK clutches. They are excellent quality and come as a complete kit for XR's and Scorpions and other cars. They can handle quite a bit of power as well.  
For the Scorpio: Part # 07-088 23 spline @ 1" 9 1/2" dia.  
For the XR: Part # 07-039 23 spline @ 1" 9" dia.  
For those doing a T5 conversion use 07-038 10 spline @ 1 1/16" 8 7/8" dia. (This is the part # for a Turbo Coupe.)

---

- Scorpio – Transmission Speed Sender Jim Brown  
**Q:** Can you provide a source for the electronic speed sender that is located on the transmission of the 1988 Scorpio. Our local Mercury dealer says this part is no longer available and one speeding ticket is enough. Thanks for your help!  
**A:** United Speedometer, Inc. (800) 854-4798 [www.speedometershop.com](http://www.speedometershop.com) Excellent full-service West Coast shop, manufacturer (US & Europe), distributor/wholesaler/retailer/rebuilder/ restorer of instruments (SW, VDO, Hobbs, Smiths, Yazaki, & others) & speed controls; huge inventory; ships worldwide. Honest. Used them since early '70s.

---

- T-9 Transmission Hard going into reverse by Michael Greiff and Bill Stobbe  
I had the same problem with my T9 transmission a couple of months ago. It helps if you put it second or third gear first and then shift to first or reverse. Of course, that doesn't fix the problem. It's probably not your clutch cable or adjuster. Your previous owner said he replaced the clutch. But did he replace the throw-out bearing and pressure plate or just the clutch disk. And did he clean all of the crap out of the bell housing and from around the bearing. That fixed mine. Shifts real smooth. My guess is that he only replaced the disk and you've got a gummed up old throw-out bearing not full releasing the pressure plate. Good luck.

---

Mike, You speak truth when you mention cleaning up the bell housing etc. There was a Ford TSB out on just these symptoms. Hard getting into reverse, and 1st to 2nd shift. The fix was to clean the splines that the clutch disc slides on. Previous owner may have had someone do the clutch, but they didn't lube the spline. Bill Stobbe Boston, MA

---

- T-9 Transmission Heat Shield by Ian Glyn-Jones  
Robb Millett Asks:  
the T-9 in my 182K mile XR4 is hissing a bit in neutral, I figure it needs a bit of fluid, but of course the crappy Chilton's manual that came with the car is no help, and the Merk owners manual calls out some kind of ford spec semi-synthetic can anyone provide me an over the counter gloop to squirt into the box? I am also planning on removing that stupid heat shield around the box and throw it as far away as I can...have others deleted this hindrance to tranny fluid maintenance?  
**A:** Do NOT throw away that "stupid" heat shield! It is very easy to remove and replace when servicing the transmission. Some have even cut a hole on the side to access the plug. This shield is very important in directing air around the casing for cooling. The T9 is under enough stress as it is and keeping it cooler will only allow it to last longer. For fluid, I use and recommend Red Line synthetic gear oil as it is a bit thicker than the original synthetic fluid that the factory used. It will help to protect the gears much better. Red Line also has a fluid similar to the factory stuff if that is way you wish to go. Keep the T9 happy and it shouldn't let you down.

---

- Issues with replacement Clutch Cables by Steve Roberts  
**Q:** Is it only me? Has anyone bought a replacement clutch cable for the XR4Ti in the past several years which is too short?  
In the last 3 years I have bought 3 clutch cables. All were too short by about 1". One from a local autoparts store (don't remember exactly which one), one from Rapido, and just yesterday one from Kragen. They are all about 1" too short. This makes installation very difficult. I ended up having to cut down the plastic/rubber assembly to gain another 1/2" or so, but still the cable was practically impossible to install.

But the cable I got yesterday is so much too short that I can't gain enough length even by cutting down the white plastic/rubber assembly as much as possible.

Do you guys have any suggestions? It seems like there are maybe 1 or 2 sources supplying the whole world, and they have their jig set up 1" too short. So they keep cranking them out too short. That's the only way I can figure it...

Any suggestions are most welcome. Thanks all!

**A:** I recently replaced the clutch cable on my '89 XR4Ti, which had broken. I had some problems. These problems will likely occur for others.

So, here's the background:

Apparently, the current European source for these cables has a couple of quality control problems. I initially bought such a cable from Rapido. On the cable box it said "The cable is pre-lubricated from the factory, and ready to install". When I compared lengths between the Rapido replacement cable and the broken original cable, the Rapido cable was definitely shorter. I initially assumed (incorrectly) that the length discrepancy was due to some stretching of the original cable due to years of use. I then also bought a cable from a local auto parts house (Parts Plus). I saw that the Parts Plus cable was identical to the Rapido cable, and was also shorter than the original cable by the same amount. The shorter length made installation almost impossible. But I got the cable installed. After installation I found the pedal pressure required to actuate the clutch was way, way more than normal. This was on my wife's car (the '89) and she could barely press the pedal. But she drove it that way, and the new cable finally also broke after about 2 months of daily use.

At this point, problems with the replacement clutch cables can be summarized as follows:

1. The replacement cables I tried (local supplier and also Rapido) have a length problem. Either the inner cable is about 1-2" to 3/4" too short, or the outer cable is correspondingly too long, take your pick.
2. The inner cable (plastic?) sheath material and the outer cable liner material have excessive friction when sliding one against the other.

Here are the solutions I used to overcome these problems:

1. I cut down the rubber doughnut and it's plastic housing (located at the firewall end of the cable assembly) by about 1/2". This resolved the incorrect length problem.
2. Before installation, I held the cable assembly vertical and dripped motor oil and silicone lubricant down the interior of the cable until it ran out the bottom.

I now installed the cable. Shortening the outer cable allowed me to install the cable without any problem, and adding the lubrication made the pedal effort return to normal. The clutch now works smoothly and easily.

I communicated my experiences with the cable to Russ at Rapido. He verified the problem, and said that until he can get the correct length cables Rapido will correct the length before shipping by cutting down the rubber/plastic assembly as I detail above. I also suggested he should make customers aware of the lubrication requirement, despite what the box says.

Anyway, if you are replacing a clutch cable for the XR4Ti, these points are worth keeping in mind.

Note: [www.autozone.com](http://www.autozone.com), they have clutch cables for \$16.99, Part Number "CA-328"

Note that it appears that currently there is one main supplier for after-market replacement cables. These cables are made in Italy, and are sold under a variety of brand names, part numbers, and for a variety of prices. A couple of examples of some brand names for this very same cable are:  
Beck-Arnley p/n 0930626  
Pioneer p/n CA328

It looks to me like many (apparently most all) of the aftermarket suppliers buy from the same vendor/manufacture. I've seen pricing for this cable ranging from \$17 to \$55. Same cable.

**A2:** Also by Steve Roberts

Here is my final fix, which has worked very well. I've tried a couple of other approaches, like cutting down the rubber/plastic assembly at the firewall, but the method detailed below has worked best for me.

One advantage of the method below is that you can correct for cables which are quite a bit too short. In my case here the inner cable was 1.8" too short initially. This is too much to be able to correct for by cutting down, or even totally removing, the firewall plastic/rubber assembly. That only gets you an inch or so at most.

=====  
Fix for too-short clutch replacement cables:  
=====

1. Remove the old cable from the car.
2. Release all the pedal adjustment.
  - 2a. By the way, here would be a good time to install the David Godfrey manual adjuster. I've got two of them. Great product. Works great!
3. Fit the new cable to the firewall and connect the inner cable end to the pedal quadrant.
4. Route the cable normally to the clutch housing.
5. Pull on the inner cable to take up all the play, and then measure how much too short the inner cable is. Write it down.
6. Remove the new clutch cable from the car.
7. Use a file and cut through the metal clamp at the clutch end of the outer cable. Pull the nylon end piece off the end of the outer cable. You'll have to tug and twist a bit.
8. Measure back from the uncovered end of the outer cable the length you measured under the car. Mark the cable.
9. Trim off the outer plastic cover from the mark to the end of the outer cable.
10. Hold the outer cable in a vise with about 3/8" protruding. Use a pair of wire cutters and grab the outer cable. Start unwinding the outer cable. Keep unwinding until you get to where you marked the cable. Clip off the unwound part of the cable.
11. Clean up the end of the outer cable with a file.
12. Push the nylon housing back onto the end of the cable. You don't need to re-clamp it.
13. **IMPORTANT:** Run some motor oil down the inner cable until you get some oil running out the other end. The cable **MUST** (in my experience) be lubricated prior to installation.
14. Install the cable back in the car, and adjust the pedal free play.

This has worked really well for me.

Cheers and happy Merkuring!

- =====  
• T-9 Transmission Removal instructions and tips by Michael Blackwelder

In the last week and a half I pulled two t-9's from my 87 and 85. The t-9 from the 85 is going into the 87 and the 85 is getting a t-5. If you can get a copy of the Ford service manual instructions for removal use them. They work pretty well.

If not, start with the shifter. Remove the console. You may try a phillips (actually they're Poz-I-Drive screws) on the screws holding the plastic that holds shift boot but you might as well have a drill handy to drill out the screw heads. Once it is out of the way you need a t-40 torx bit to remove the shifter. Stick a paper towel in the hole to keep the rust and dirt out.

Remove the exhaust bolts from the back of the turbo. There are two of them. Remove the bolts from the flange after the cat. Remove the exhaust section.

Take out the four bolts from the rear driveshaft flange. Take out the two bolts from the center bearing. Notice the two washers that may be between the mounting flange and the body. Put them back the same way when you re-assemble.

Remove the sway bar clamps and the chassis stiffening bar. Put a piece of two by four between the body and the sway bar to keep it out of the way.

Decide if you want the transmission oil on the floor or in a pan. When you pull the driveshaft out it will drain from the rear if it is full like it is supposed to be. You may want to pull a bottom bolt and drain the transmission because if you don't have a spare front yoke when you tip the transmission getting it out it will be all over the floor.

Disconnect the neutral safety and backup wires from the switches at the rear of the trans. Disconnect the speedometer cable. Put a block of wood under the clutch pedal to raise it as far as you can. Go under the car and release the clutch cable.

Support the rear of the transmission and remove the bolt in the center of the crossmember. Remove the four nuts holding the crossmember to the body.

Remove the starter. Lower the rear of the transmission. Loosen the nuts on the motor mounts. Put a jack under the front crank pulley and lift to tilt the engine. Remove the bolts holding the transmission to the engine.

Get your second person and pull the transmission back and tilt it down while removing it. You may be able to get it out by yourself but unless you are built like Arnold Schwarzenegger was you won't be putting it back in yourself. Don't cut corners by not replacing the pilot bearing or clutch release (throwout) bearing. This job is such a pain doing it a second time for something so trivial isn't worth it.

The top bolts on the bellhousing were easier to use wrenches on my 87 than on my 85. The tunnel is a little wider. I actually got a air ratchet in there. Anywhere you can fit an air impact wrench or ratchet to get bolts off do it. Use discretion when putting the bolts back on.

It helps to buy a clutch package because they usually come with a plastic alignment tool. If you see signs of rear main bearing seal leakage now is the time to replace it. If you get this far you will be able to put it back together. Have fun.



## Transmission Conversions for the XR

---

- Going from Auto to T-5 by FRMRPRO and Tony Vissoc

**Q:** If anyone out there has done this conversion, I would appreciate them sharing their experience. I am wondering what parts I need from a donor XR4 5-speed to convert my 89' XR4 automatic to a T-5? I have thought of the obvious, Pedal assembly, Clutch cable, Center Console Surround, am I missing anything? Thanks Darren

**A:** Since no one's answered, I'll take a shot... Haven't done a swap like this, but I have both auto's & manuals (T5). Your list reads like you've got or plan for the basic stuff you need, but make sure you get a manual EEC, and check on the turbo and your choice of tranny gearing. If you're keeping your auto differential, then think about the different gearing (3.36:1 vs. 3.64:1 for a manual) and picking the right T5 gearing to match. Also, I think some (early)/all auto XR's might have come w/ the smaller A/R (0.48) for quicker spool up. The smaller AR could offset the performance drop from using a tall T5 1st & 2nd gear (e.g., 2.95, 1.94, etc.) w/ the tall auto diff. unless you're doing a lot of highway driving, you'd probably be happier w/ a shorter ratioed T5 (e.g., TBird, or SVO, or other Mustang with a 3.3 or 3.95 1st) to compliment the taller auto diff. ratio. OTOH, if you DO have a 0.48A/R turbo, remember that you'll get quick spool up, but not a lot of top end compared to a 0.63A/R. If that's your situation, and you don't plan to upgrade your turbo, you might like the taller ratio 1/2 T5 (e.g., 2.95 1st) just because you won't have to be shifting so quickly out of 1 & 2. Presume you've got all the normal T5-conversion components you need too (see archives), such as the correct bell-housing, slip yoke & Spicer u-joints, tranny mount (Rapido, or convert your stock), and a good driveshaft or trucking equipment/repair shop. If you don't have the Rapido hunk-o-iron, you'll have to create a way to adapt the normal T5 bushing to your stock cross-member bushing. Don't forget to block off the vacuum line(s) used by the auto. Check to see if you have your neutral start, BOO and other connections in your wire loom in case your manual EEC needs them (you'll need a wiring diagram/schematic and/or Allan Slocum's manual to identify the pins), then check the pins in your wiring loom @ the EEC connection. I think all the wires you'll need are in your auto-tranny harness and capped off & probably dangling from the harness under the dash, but be prepared to have to find a manual wiring loom. Just a total guess, but if you have cruise control, you might have to check wiring/vacuum on that too to see if there's a direct hook-up or read from the auto tranny. Also check for any differences in feeds/hoses between the auto & manual radiators and your reservoir - I know they use different hose arrangements, just can't remember why they're different, or if you need to add/reroute for the lower reservoir nipple, which is capped for the auto. I hope that helps.  
John

### **Tony Vissoc adds:**

Yeah. Get the computer from the 5 speed XR... Especially if it is a PF3. Then, sell it on Ebay and buy yourself a manual boost controller to get your 15psi.

If you're keeping your auto differential, then think about the different gearing (3.36:1 vs. 3.64:1 for a manual) and picking the right T5 gearing to match.

My XR is originally an auto. My first 5 speed swap was a T-9, and that was pretty nasty with the 3.36 rear. I ditched the T9 after it refused to find 5th gear. I replaced it with a T5 from an '89 2.3 Mustang. The gearing is just about perfect for that differential, and I didn't even have to change the speedo gearing. The automatic speedo cable worked just fine.

Also check for any differences in feeds/hoses between the auto & manual radiators and your reservoir - I know they use different hose arrangements, just can't remember why they're different, or if you need to add/reroute for the lower reservoir nipple, which is capped for the auto. Just pull the tranny cooling lines from the radiator and you're done.

- 
- Speedo gears to use for T-5 swap by Joe Schesso and Brad Anesi

**Brad:** Also note that a 20-tooth speedo driven gear is likely a better match than the 19-tooth noted

here, when using a 6-tooth drive gear. Unfortunately, I've still got a 7-tooth drive gear in there, which needs a 22.5-tooth driven gear. Best to get a 6-tooth.



**Joe:** I got a T5 from an 89 5.0 Mustang w/ the 7 tooth gear. Steeda sells a 23 tooth speedometer gear that I got for \$20 from a local Mustang specialist.

**Brad Anesi:** \$20 sounds awfully expensive - I got mine for about \$7 or so. The problem with the 23 tooth is 3-fold...

1) As indicated below, a 23 x 7 gear combo with a 3.64 rear and stock size wheels results in a 5% speedo error

2) The 23-tooth driven gear is prone to disintegration due to the paper-thin cogs

3) With the 23-tooth gear, smooth rotation of the speedo cable is "challenged", causing the speedo to

have a jumpy indicator and making cruise control pretty much unusable.

**Joe:** For some people it may be easier to find a transmission with a 6tooth gear than a 7 tooth. I found my WCT5 for \$300, rebuilt w/ HD parts, so it was better than finding a T5 for the same price with a 7tooth gear out of a junked car w/ no history. And if you're spending \$1000 for a swap, \$20 is pocket change. And Lets take a look

1: Most speedometers are off by 5% from the manufacturer anyway and 5% is not a big difference, 100mph +/- 5mph, lower speeds will be less than 5mph difference. 30mph +/- 1.5mph, 60mph +/- 3mph. Not a big difference at all.

2: I've been using my cog for more than 3 years, no problems here. Maybe you had the cable kinked too much, causing too much stress on the gear.

3: I have absolutely no problem with my speedometer bouncing or jumpy needle, and my cruise works just fine. Again maybe you just had the cable kinked too much, causing too much stress on the cable. Maybe you've just had some bad luck, or maybe just some cable routing problems.

- 
- What gear do I have in my T-5? by Brad Anesi

**Q:** Does anyone know which speedo drive gear an 89 4cyl T5 transmission might have? I'm not sure if it is a 7 tooth or a 6 tooth.

**A:** I believe it's a 7-tooth, but don't hold me to that. If you've got the T5 at hand, it's easy enough to check it. Just shine a flashlight in the speedo gear hole - if it's yellow, it's 7-tooth; black, it's 6-tooth (which is what you probably want).

Bear in mind, the formula you typically see floating around the Internet for calculating driven gear requirements doesn't apply to a Merkur speedometer head. The one on MerkurTech is correct however, as it factors in my suggestion to add ~1.2 to the result you get from using the US spec Speedo head calculation.

- 
- T-5 Transmission Fluid by Eric

**Q:** I use regular ol' ATF in all my T5s. Usually the cheapest I can find. Never had a problem with the transmission due to lack of lubrication. The internals have always looked good when I pulled them apart, other than the obvious operator induced damage ;) T-5s use just under 3 quarts.

- 
- Cobra T-5 in the Merkur by Timothy Spencer

If you so choose to use the "Z" spec or "cobra" spec T-5, have the 5th gear changed (.63 is stock for that trans) and definitely have a manual diff (3.64 axle ratio). I personally recommend the "standard" V8 tranny with the 3.35:1 first (.68 5th). All the ratios are nicely spaced (first hand experience) and it is a very strong tranny, also inexpensive. You need to have the input shaft turned or a pilot bushing made to fit into the 2.3 crank.

Here's something to consider. The reason the cossie had the tall gears was that it came stock with about 75hp more than the XR. It also has 2 cams, making breathing better and a much flatter power curve, not relying much on the turbo to make it. Depending on how the 2.3T is tuned you may want lower gears. It's all dependent on tuning. You don't want to have to clutch too much on a start-up, I don't think you are making a race car.

Another thing to consider. ratings for transmissions (the T-5 at least) are based on overall reliability over 60,000 miles. How many XR owners with over 300hp are gonna drive more than

60,000 miles in the next 10 years, not many I presume. I've seen standard V8 spec (3.35 1st) trannies last many passes with 550hp mustangs. So don't go thinking that just because you are making over 300hp that you're going to have a problem.

- T-5 Transmission Identification by Bill Stobbe

**Q:** Hi All: I read some msg's from folk's who have T-5's. I have one in mine that was installed by the Rapido guys. I have no idea what year it is, or what it came from orig. I seem to have a 3:64 rear ratio, but have no idea what the ratios are in the tranny. The main thing I don't like is the gap between 4 and 5th. At 55mph, for instance, in 4th its revving too high, but going to 5th it just lugs badly. At 65 or higher, 5<sup>th</sup> is useful, but that's it. Anyone know how to read the tags on the transmission?

**A:** First, go to the upper left bolt on the T-5 tailshaft and look for a aluminum tag. It has the Borg Warner Part #, which starts with 1352-xxx.

Then, Go to <http://www.turbotektoys.com> , pick TIPS, then T-5 DIFFERENCES on the left column. The Borg Warner part numbers are there along with the tranny ratios.

My Rapido unit is 1352-169. Gears 1->4 are fine, 5th is too low, 0.68. Sounds like yours.

- Is This a C-4 Bellhousing ? by Chad Hayes

**Q:** Found an auto trans from a 74 2.3 Pinto. There are 8 holes on the trans side instead of 7 like I have seen. How can I determine what it is? How many pan bolts does a c-4 have?

**A:** This is a pinto C4 bellhousing.



Anything else is not. The transmission next to it is a big case C4 looks a little different then the smaller pinto C4 notice the mounting holes on the case of the big case pre 1970 transmission.

differences between C3 and C4:

Easist way to tell if the tranny is in the car is by the tranny cooler lines. if they both go into the tranny right next to each other toward the front of the tranny it is a C4 if there is one toward the front and one towards the rear then it is a C4. you can reach under the car and feel around for this.

There are only 7 front pump bolts to bolt the bellhousing to the tranny. you can see that in the pic. Anything else and it is a C3.

- Automatic to Manual transmission swap by Cliff Walton

**Q1:** Will that tranny fit in my car without modifications? and, if not; what are the modifications to do?

**A1:** Having done 3 of the automatic to 5 speed swaps, I can tell you that it's a fairly

straightforward and simple process. I just finished the last one about a month ago. To answer your questions in order:  
Yes. Physically it will fit with out any sheet metal modifications.

**Q2:** A friend of mine says that there is two different 5spd trannys that came originally on the Merkurs. The first kind on the 85-86 and they put a similar but different in the 87-89. Is that true or what?

**A2:** Either one will work. Differences are internal.

**Q3:** Do I need the swap computers?

**A3:** You don't need to, but if you can get a PF3 (the one that came on 5 speed cars), get it and replace the PK1 (auto equipped).

**Q4:** What else do I need to know about all these project?

**A4:** You will need the pedal assembly out of the 5 speed car. It is very easy to remove, only 3 bolts. It is a direct swap for the auto brake pedal assy.

You will also need:

1. Clutch cable
2. Clutch cable grommet on firewall (engine side). Grommet is secured by a metal ring and 2 screws.
3. Shifter, boot and shifter surround (the piece that holds the window switch).
4. Clutch, pressure plate, throwout bearing (recommend you buy a new set). You'll also need pressure plate bolts (6).
5. Input shaft (pilot) bearing. Mounts in end of crankshaft. Available at any local auto parts store for about \$7-8.
6. Flywheel and bolts. The auto flex plate bolts are different and won't work. Make sure you have the flywheel re-surfaced.
7. Driveshaft from 5 speed car, at least the front half. It's easier to replace the whole thing. Recommend installing a new guibo while you have it out and check the center support bearing.
8. Check your tranny tunnel width at the tranny crossmember against the donor car. 85 and early 86 XR's had a narrow tunnel. Regardless, you can use the stock crossmember.
9. Speedometer cable from 5 speed. Cable is secured to tranny with circlip vs. the bolt on the auto. If you have cruise control, it might make things more difficult getting the correct cable, depending on which version of cruise control the car has. Also, it's easier to install the circlip before attaching the tranny crossmember.
10. Wiring pigtail (from 5 speed car) and reverse and neutral safety switch (should be on manual tranny). Plugs right in once you unplug the auto wiring

11. Differential (optional). The auto cars used a 3:36 vs. the 3:64 on the manual cars.

12. For the most part, the project was a direct bolt in. The only minor modification I had to make was where the shifter came up into the car. There are 4 captive nuts for securing the shifter boot that are in the wrong place when you do the swap. Two are on a small metal plate that is riveted to the car. You can drill them out and reposition it where you need it, then re-rivet. It should be obvious when you put go to install the shifter. Make sure you remove all the auto related stuff. You can leave the behind the bumper mounted tranny cooler in place and reuse it as a power steering cooler. Make sure to remove kick down cable and plug the vacuum port on the vacuum distribution tree that feeds the vacuum modulator.

With all that being said, the swap is relatively simple. Figure on a weekend, one day if you're quick. Good luck and enjoy.

# Borg-Warner T-5 Transmission Data

B/W Id	Source	Application			Torque Max (lb/ft)	Gear Ratios						Speedo Drive Gear	Input Shaft length	Input Shaft Pilot Dia (in)	Notes
		Year	Model	Engine		1st	2nd	3rd	4th	5th	R				
114	Factory	85-86	T-Bird	2.3 T	235	4.03	2.37	1.49	1.00	0.81	3.76	6	7.41	0.59	
115	Motorsport	79-83	Mustang	5.0	305	2.95	1.94	1.34	1.00	0.63	2.76	6	7.18	0.668	a
116	Factory	85-86	SVO	2.3 T	250	3.50	2.14	1.39	1.00	0.78	3.39	6	7.41	0.59	
126	Factory	85	Mustang	5.0	265	3.35	1.93	1.29	1.00	0.68	3.15	7	7.18	0.668	
141	Factory	86	Mustang	5.0	265	3.35	1.93	1.29	1.00	0.68	3.15	7	7.18	0.668	
154	Factory	87	Mustang	2.3	240	3.97	2.34	1.46	1.00	0.85	3.70	7	7.41	0.59	
155	Factory	87	T-Bird	2.3 T	240	3.97	2.34	1.46	1.00	0.79	3.70	6	7.41	0.59	
162	Factory	87-88	Mustang	2.3	240	3.97	2.34	1.46	1.00	0.79	3.70	7	7.41	0.59	
165	Factory	86	Mustang	5.0	265	3.35	1.93	1.29	1.00	0.68	3.15	7	7.18	0.668	
169	Factory	86.5-89	Mustang	5.0	265	3.35	1.93	1.29	1.00	0.68	3.15	7	7.18	0.668	
194	Factory	89-90	Mustang	2.3	240	3.97	2.34	1.46	1.00	0.79	3.70	7	7.41	0.59	
199	Factory	90-91	Mustang	5.0	300	3.35	1.99	1.33	1.00	0.68	3.15	8	7.18	0.668	b
200	Motorsport	79-93	Mustang	5.0	305	2.95	1.94	1.34	1.00	0.63	2.76	7	7.18	0.668	a
202	Aftermarket	79-93	Mustang	5.0	305	2.95	1.94	1.34	1.00	0.80	2.76	7	7.18	0.668	c
204	Service	85-89	Mustang	5.0	300	3.35	1.99	1.33	1.00	0.68	3.15	7	7.18	0.668	
207	Factory	91	Mustang	2.3	240	3.97	2.34	1.46	1.00	0.79	3.70	7	7.41	0.59	
208	Factory	92-93	Mustang	5.0	300	3.35	1.99	1.33	1.00	0.68	3.15	8	7.18	0.668	d
209	Factory	92-93	Mustang	2.3	240	3.97	2.34	1.46	1.00	0.79	3.70	7	7.41	0.59	
218	Factory	93	Mustang	Cobra	310	3.35	1.99	1.33	1.00	0.68	3.15	8	7.18	0.668	e
219	Factory	94	Mustang	5.0	300	3.35	1.99	1.33	1.00	0.68	3.15	8	7.85	0.668	
220	Factory	94	Mustang	3.8	265	3.35	1.93	1.29	1.00	0.73	3.15	7	7.85	0.668	
225	Aftermarket	79-93	Mustang	5.0	325	2.95	1.94	1.34	1.00	0.80	2.76	7	7.18	0.668	b,c,d
227	Motorsport	79-93	Mustang	5.0	325	2.95	1.94	1.34	1.00	0.63	2.76	7	7.18	0.668	b,c,d,f
236	Factory	94 1/2	Mustang	3.8	265	3.35	1.93	1.29	1.00	0.73	3.15	7	7.85	0.668	
238	Factory	94-97	Mustang	3.8	265	3.35	1.93	1.29	1.00	0.73	3.15	8	7.85	0.668	
239	Aftermarket	93	Mustang	Cobra	310	3.35	1.99	1.33	1.00	0.68	3.15	8	7.18	0.68	c,e
242	Factory	94-95	Mustang	Cobra 5.0	310	3.35	1.99	1.33	1.00	0.68	3.15	8	7.85	0.668	e
246	Factory	94-95	Mustang	5.0	300	3.35	1.99	1.33	1.00	0.68	3.15	8	7.85	0.668	
249	Motorsport	79-93	Mustang	5.0	330	2.95	1.94	1.34	1.00	0.63	2.76	7	7.18	0.668	e,g
251	Aftermarket	79-93	Mustang	5.0	330	2.95	1.94	1.34	1.00	0.63	2.76	7	7.18	0.668	c,e
253	Aftermarket	94-95	Mustang	Cobra 5.0	310	3.35	1.99	1.33	1.00	0.68	3.15	8	7.85	0.668	c,e

Input Shaft = 1-1/16 inch/10 spline  
 Output Shaft = 28 Splines

Notes: a) Motorsport M-7003-A    b) Improved Steel Alloy    c) Aftermarket    d) Carbon fiber 3/4 blocker rings  
 e) Cobra tapered roller pocket bearing    f) Motorsport M-7003-X    g) Motorsport M-7003-Z

## Car Won't Start

---

**Q:** Hello-I took my 15 yr old daughter out for a driving lesson in the Merkur. Seems important to teach her how to drive a manual. Anyway, after she stalled it trying to get it going in first for the 5th or 6th time it would not restart. It turns over very easily. Can the inertia switch be triggered by stalling the car? Is there an inertia switch? It was quite a jolt. I plan on working on it tonight (it's across town) and don't know as of yet if it's fuel or spark or what. If it is the inertia switch, where is the reset? I should have a better idea after I have a chance to take a good look at it. Thanks.  
Mark D.

**A:** Richard Curtis writes--- It doesn't sound like inertia switch to me (it takes a heckva jolt to trip it). Switch is in the spare tire well... easily seen even without removing the spare. I think it's a white button. Couldn't hurt to try that. Just push the button to reset. Sounds like TFI, which would not be unusual and not related to your daughter driving the car. Check for spark at the spark plug. If spark, it's most likely NOT the TFI. Note the color of the spark; if it's yellowish-orangish-reddish, then you've got a weak coil. I've observed Merkurs with that color of spark that would not start. You should have a blue spark. Then check to see if the timing belt broke (you can look just beneath the timing belt cover to see if the cam is turning over while your daughter cranks the car, or you can look through the inspection hole on front of timing belt cover. Then check to see if you're getting fuel into the combustion chamber. Spark plug should be wet. If not, you've got a fuel-delivery problem (fuel pump, fuel pressure regulator, injectors, and wiring harness). You should also check for compression but even without compression on 1 or 2 cylinders, it should start (although will run like crap). Before you do any of this, I'd check the codes (you do have a code reader, right? \$25 at Sears and most auto parts stores). When I rebuilt the engine in my 89, it wouldn't start. Codes showed that the TPS had jammed full open. Car won't start if it thinks you're at Wide Open Throttle (WOT). Hope this helps.

**Q:** Well, the car is getting gas. The coil is not producing spark. When the ignition is switched on the red wire going to the coil produces 12v but the green/yellow wire produces nothing. I do not as of yet have a code reader but that may change tonight. Any suggestions based on this?-Mark Durso.

**A:** Al Lawler wrote: I'll bet you a case of beer it's timing-belt related...

**Q:** Pardon my ignorance, but how would the timing belt influence the operation of the coil? It is not broken but it could have slipped a tooth. -Mark Durso

**A:** Hey Mark, The repeated jerking from stalling could have stripped some of the cogs off of the belt. Just have someone crank the engine over and watch to see if the cam turns. If the belt doesn't move, neither does the distributor and the TFI never puts out the signal to fire the coil. Generally, the coil will only be 'hot' on the one side: the other side is grounded except when triggering spark. If you hold your meter on the one side, the voltage should fluctuate as you crank the engine. It should also be noted that TFI's go bad way more often than do coils. Most parts stores can test the TFI if you remove it (requires a special 5.5mm socket).-- =====  
Tim O.

**A:** Hi mark, the timing belt causes the valves to open/close in sync with the piston action. (The cam and crankshaft are held in the same relative rotational position by the belt.) Also, one of these parts (Not sure which) drives the auxiliary shaft, which causes the distributor to turn (which in turn provides a feedback signal through the hall effect sensor to the EEC-iv which then decides when to generate a spark pulse. If the belt jumped a tooth, you may have open valves when the piston "compresses", or a spark happening at the wrong time...I'm intrigued by your earlier comment about the car turning over 'easily'. (if it seems more "easy" than usual, you probably do have a timing belt problem of some sort. My suggestion is to:

- 1) Remove the distributor cap and make sure the distributor really turns when the engine is cranked. (It's possible that the auxiliary shaft broke, although unlikely.)
- 2) Line up the bottom timing mark on the pulley against the index point, then pop open the little plug in the plastic timing belt cover and make sure the camshaft index mark is at the center of the little pointer.
- 3) Lastly, it "could" be the TFI module, but that would be sort of a big coincidence...

Do you have a code-reader? Can you see what the eec-iv error codes say?  
Al Lawler

Hi- Since the distributor is run off of the crank, wouldn't it still fire the plugs even if the timing belt slipped? How does the coil know where the camshaft is? I would think that you wouldn't even need the camshaft for the coil to fire. Am I missing something?- Mark Durso

- Distributor Gear and Auxiliary Shaft by Robert Scanlon  
I found the cause of my engine stalling and not restarting, it was a stripped distributor gear. One tooth looked like it was broken off for some time since the color was very dark compared to the shiny 4 teeth that were broken on both sides of the dark one. After replacing the distributor an old problem was resolved, intermittent stumble in the idle.

Seems I missed a problem with the Aux. shaft when I replaced the distributor. I checked to see if it turned freely but I did not notice a chip.



## Troubleshooting

---

- Start with the engine Grounds first by Bill Stobbe and Tony Vissoc

**Q:** I am having trouble with intermittent problems that seem like electronics, anyone out there had problems with the EEC (engine electronic control ) ?

**A:** Hmm, I had a failure with my car and it was a combo of the EEC and a not connected ground wire. Check the one that connects to the battery box underneath, make sure it is on. There is another hooked up to the intake manifold on a brass stud. A third down below the reservoir to the steering pump. I suspect the ground missing had something to do with the EEC going bad, but I cannot prove that.

**Q:** Did I miss any?

**A:** Yeah, the one connected to the turbo inlet.

Anyway, it is a good idea when things start getting ugly, to remove/clean/replace any and all grounded connections. Same goes for vacuum lines. They may look ok, but could be bad. I'm due to go through all of mine.

---

- Running rich Condition by Tim O.

**Q:** Hello. I am trying to figure out why my car is running rich. I have posted before and got some suggestions on what to check, now I am back with more questions. I am wondering if I could have a bad BAP. The BAP is on the passenger side by the battery I believe. There are two things there, which is the BAP? Can I have a bad BAP, and how can I tell?

**A:** BPS/BAP is the small black box; roughly 2" x 3" x 3/4". Can only check the BPS with a frequency meter....or swap in another to see if it changes anything.

**Q:** I also un-hooked my PE and put the stock ECU back in. Less black smoke out the tailpipe, but still runs rough when I really put the pedal down. After the ECU change the symptoms are almost the same, but on a smaller scale. Could this be from the different fuel curves? What are the symptoms of a bad VAM?

**A:** Runs like crap. ;-) Can cause a rich/lean condition. Check voltage out at idle: ~1.18V and do a sweep test to ensure there are no bad spots. Should go to >=4.5V.

**Q:** I seem to have no leaking injectors, and fuel pressure is ok when I rev it How long does the fuel rail hold pressure after shutting the car off?

**A:** Fuel rail should lose no more than ~2 PSI in 5 minutes; otherwise indicates leaking injector(s) or an external leak. An external leak won't cause a rich condition and should be fairly obvious at idle.

**Q:** I am unable to check under boost. Spark plugs and wires are less than a year old. What are a good set of plug wires? Does a sensor report temp of the engine to the ECU, and if so where is it? Could that sensor be telling the ECU the engine is cold and that is the source of my richness?

**A:** ECT reports engine temp. to the computer and could cause a rich condition if it always reports a cold condition. It is located in the lower intake manifold, centered front to back, between #2 & #3 injectors.

**Q:** In what order should I set the IAC, TPS, and Timing?

**A:** Timing , IAC(actually base idle,) TPS. One way to (roughly) check base idle if you don't have an accurate Tach, is to check the voltage at the ISC/IAC. Should be ~9.5 - 10.5V. A higher reading indicates base idle too high; lower reading indicates idle too low.

**Q:** Other than not being able to really put the pedal down the car runs great!

**A:** If it only runs rich under boost, you could be losing pressure somewhere which will also cause it to go rich.

---

- Poor Idle fixed by solving vacuum leak by Dale Millar

Lousy idle and stalls until fully warmed up for the last 2 weeks. Took a quick visual under the hood without anything jumping out at me. Looked at archives a few times to plan out a diagnosis. Went back out and physically put my hands on every vacuum hose I could reach. Hands got real dirty. Found one connection off and one very little hose with one very little crack. Reconnected and replaced. Idles and runs great. We hear it all the time...because its the truth. Look for the simple fix first!

- 
- Fast Idle by Scott McClure and John Sasso

**Q:** Once again, I'm driving around town without the need to push the accelerator. My car's overly-fast idle is doing it for me! GRRR! I've checked the TPS. Calibrated correctly with no dead spots. I even used an analog meter as well so I could see the needle sweeping. All seems to be well there. When I disconnect the ISC, all is well. Idles around 750. I measured the voltage between the ISC and ground. It measures to be ~13.5 volts. Is this a bit high? If so, is my EEC in need of replacement? How about a new O2 sensor? New ISC? What tells the EEC what signal to send to the ISC? Thanks again, all...Kevin

**A:** Check to make sure the hood-liner is not drooping low enough to hang up on the throttle assembly. I had this same intermittent high idle, and it turned out to be exactly that. Scott McClure

**A:** I just had this with my car also. I was able to get a FORD OE replacement TPS and the problem is now gone. The failed part would allow setting the TPS, but the first couple of 'floorings' would cause the idle to go up again. Hope this helps.

- 
- Help for Passing Emissions Tests by Jeffrey Shvak

**Q:** Alright guys, I failed today and was surprised with the results. My HC was at 122.0, and CO was a whopping 3.31. What do I do to fix this and be clear for another two years?

**A:** What type of test is this? Is it just checking emissions at idle or do they take the readings on a dyno at cruising speeds? At any rate, the numbers you are showing seem to indicate a rich condition. If you haven't already, give the car a tune up, change the oil, dirty oil is full of gasoline and carbon that will get sucked into the intake of the engine by the PCV valve and could cause a rich condition. Check for a vacuum leak, unmetered air will be seen by the O2 sensor as a lean condition and the computer will enrichen the mixture to try and compensate. Make sure your engine is thoroughly warmed up for the test so it can run as efficiently as possible. If your O2 sensor has over 50,000 miles on it, you may want to replace it with a new one. Although I've used the original one for well over 120,000, it is something you could try. That high CO reading is indicative of low heat combustion...suspect the converter not getting hot enough or your fuel isn't burning all the way. Try a tank of the cheap gas, 87 octane, the lower grade will burn more completely under the lighter load conditions of an emissions test. Keep us informed.

- 
- Irregular Idle by Andrew

**Q:** I have an '88 XR4 which is in good condition, but which has an odd hiccup in its idle speed. I will be sitting at a stoplight with the car idling normally when it suddenly almost stalls and then recovers to a normal idle. It's an annoyance rather than a problem, but does anybody have any suggestions as to what causes it and how to fix it?

**A:** The classic repair is to clean the ISC. Take it out, separate the 2 halves and soak the lower in brake cleaner overnight, dry it out and squirt WD40 and reassemble and reattach to TB

- 
- Annoying XR Idle Stick by Steve Leiding

**Jeremy Hidy asks:** No, it's not log, it's annoying idle stick, by whammo. Does anyone know how the idle bypass works? I keep getting an annoying idle stick at 2000 RPMs.

**A:** It controls idle speed by bypassing air around the closed throttle plate. Take the IAC off and clean it and the throttle body with carb or throttle body cleaner. It gets plugged up with goo from the EGR.

- 
- XR Won't start... by Richard Curtis and Bill in Boulder

**Q:** My car won't go. What do I do ?

**A:** Okay, one last time, here's the deal if your car won't start:

1. First, run the codes. If your TPS is stuck wide open (don't laugh, it's happened), the car won't start because the electrical signal to the injectors is turned off. Codes could also tell of other problems leading to no-start.
2. If no codes, check for fuel at the spark plug. Pull a plug; if it's wet with fuel, you're getting fuel there. If no fuel, check for OUT OF GAS (don't laugh; it happened to MY son), faulty fuel pump, faulty fuel pump relay, faulty fuel pressure regulator, injectors not firing etc.

3. Now check for spark. Ground the spark plug you just took out by slipping it back into the boot and touching it to the block. Have son grind on the starter while you observe color of spark. If no spark, change first the TFI; if still no spark, change the coil. If spark is any color other than blue, change the coil.

4. If still no start, check that timing belt is not broken (look under the belt cover while son grinds on the starter, or pull the distributor cap and crank to see if the rotor turns).

5. If it's none of these check for compression. But for car not to start for lack of compression, you would almost have to have zero compression in all four cylinders.

If car has compression, fuel, spark and even-in-the-ballpark timing, the car should start. If none of these works, run codes (or run the codes at the beginning). All of this assumes you have a strong battery.

Other possibilities: Throttle Position Sensor is stuck in full open position. This cuts off fuel to the injectors. Your Engine Coolant Temperature sensor is gone bad. The EEC (computer) is dead. Exhaust system is clogged. You're out of gas. An inoperative Barometric Pressure Sensor. Vane Air Meter is stuck open or closed. etc., etc.

**Chris Senior adds** : Don't forget to check the connection and condition of the IAC too!!!

**Bill in Boulder adds:**

Having been had twice on this problem I would lightly rest my fingers on the back of the cam sprocket the first time I cranked the motor over! A stripped cam belt has symptoms identical to a failed TFI! Ask me how I know this (and why I have a spare TFI!)

- Bad Starter Solenoid ? ... by Tony Vissoc

**Q:** Last night when I left work the car wouldn't start. A coworker tried giving me a jumpstart, but the starter solenoid just chattered; the starter didn't turn. As a final resort, I tried bridging the starter solenoid with the jumper cables and it started right up. I stopped at a local auto parts store and had them test the battery. It passed with flying colors. Their computer didn't list a starter solenoid for the XR. Another auto parts store listed a starter solenoid, but when they brought it out to the counter it didn't look anything like what's in my XR. I thought our XRs used a fairly common Ford solenoid; does anyone know anything about this? Also, the car's started just fine since then. Am I barking up the wrong tree with the solenoid?

**A:** Most starting problems like this are due to a bad ground. Try cleaning up your ground connections. If that doesn't help, replace cables.

One day, my XR just decided not to start. I swapped solenoids, starters, cleaned grounds. No go. Got (made) new cables. Bingo!

Check to see if any of the cables get warm to the touch when attempting to start. This may indicate bad cable or connection.

- Bad VAM (vane air meter) ? ... by Larry Biles and Nick Larson

**Q:** Larry Biles asks what are the symptoms of a bad VAM ?

**A:** I had a very similar problem on my XR.

The fundamental symptoms I had:

Dreadful mileage.

Lumpy idle.

Engine would hardly idle when it was hot, and actually frequently died.

Would not knock at all under any boost condition.

Plenty of black smoke under acceleration.

Flunked smog test (by a country mile) on the dyno here in California.

After probably a similar amount knuckle busting and hair pulling, finding nothing wrong, I took the car to a trusted repair/smog inspection shop.

They checked everything, and found nothing wrong. He could get the computer to run closed loop if he pulled a vacuum line. His final answer was that he thought it was the VAM.

Turned out he was right. I replaced the VAM with one I has scrounged from a junkyard, and the car ran like a top.

No lumpy idle, great mileage 24 MPG instead of 17, hot idle control came back, no smoke on acceleration, and best of all, it passed the smog test.

Unfortunately, it will occasionally knock under boost, but I'll live with that :-).

Good Luck, let me know how it turns out. It sure sounds like you have the same problem.

BTW, my car had almost 200k on it when the symptoms started. I suspect that the (bad) VAM was original.

- 
- Bad BAP sensor (Barometric Air Pressure) ? ... by Richard Curtis

**Q:** What are the symptoms of a bad BAP ?

**A:** Usually when a Barometric Air Pressure sensor goes bad, you'll get a bad idle at cold start up but it usually clears up when the car is warmed. Also known to happen when wet, damp, cold, etc. That's been my experience. First thing I would check, though, would be Throttle Position Sensor (check the voltage), and also run the codes. Hope this helps.

- 
- High Intermittant Idle Diagnosis ... by Tony Vissoc

**Q:** Russ Moorman asks:

Here's the scenario. After warm-up the idle will fluctuate between 1500 & 2000 rpm. Sometimes (but not often) I can blip the throttle and get it to settle down. More often I wait 'till I'm sitting at a light, shut off the engine, wait ten seconds, restart. It will then settle down to 900-1000 rpm, for a while - sometimes for the duration of the drive, sometimes not.

A stop and start of the engine as described will fix it (temporarily) 100% of the time. If I unplug the IAC, the idle drops to 750 rpm every time. Here's what I've done so far:

1. Cleaned the IAC - twice
2. Lubed all throttle linkages
3. Set timing to 10 deg - spout out
4. Set idle @ 750 w/TPS .95 - .99 - IAC unplugged

Help!

**A:** Tony Replies:

I've had this problem, even with a seemingly good TPS. Changed TPS and all was good.

Recently had same problem again. I did a number of things at the same time, and my idle was fixed. Here's what I did that resulted in a nice idle. I have no idea which item cured the problem.

1. Deleted all non-essential vacuum lines in search for a vacuum leak.
2. I pulled the throttlebody and cleaned with carburettor cleaner.
3. I pulled the TPS while the throttlebody was off. Reattached and adjusted. Was careful not to over-tighten the TPS screws. I was considering the possibility that the TPS was binding due to overtightened screws.
4. Shot a squirt of lube into the IAC (IAC was super clean already)

All gaskets were replaced on items I pulled. Except for the TPS gasket.

So, there you are. I have no idea which item was the cure. I did notice that my spare IAC had the engine RPM cycling up and down. I suppose a bad IAC actuator could create problems. Maybe find a buddy with a good idle and swap on his IAC for kicks.

I intend to start adding back in the vacuum circuits. I have absolutely no vacuum operated devices hooked up with the exception of those essential items, like brake booster, wastegate actuator and my cherished Gillis boost adjuster. The rest is capped off at the tree. Oh, I do still have the boost gauge hooked up.

---

- Bad VAM Causing Intermittent Sputtering and Black Smoke at full boost ... by Terry Watson

**A:** Most likely a bad VAM. They can stick intermittently, and they can also give bad readings as they are opening. I had one stick partially open and the car would run really rich. Then the vibration from driving would eventually shake it loose and it would then run fine. Drove me crazy until it happened one day when I could shut it down, then pulled the hose from the VAM to the turbo and looked at it with a mirror & flashlight. Damn thing was about half way open.

You can check the wiper readings by putting a analog voltmeter (needle type) across two of the wires to the VAM. You will probably have to remove it from the mounting bracket. Find the two wires that start at about 1 volt and increase to almost 5 volts as you open the VAM. Ignition needs to be turned on! Move the VAM door slowly with your fingers and watch the volt meter to see that the voltage increases smoothly with no dips or flat spots. If that is okay, then actuate it by hand MANY times. Mine would hang up every 40-50 cycles, and was never able to get it fixed right. <SEE ALSO "INTAKE SIDE OF MOTOR FOR MORE ON VAM TROUBLSHOOTING"> -Ed.

## Turbocharger

---

- I just got off the phone with United Turbo Co. (800-779-1780). The guy that answered was friendly and perfectly willing to take the time to answer a few technical questions. I didn't buy anything from them, but he made a good first impression.

For the record, his answers were: The bolts holding the wastegate to the compressor don't need thread sealant or red loc-tite, but blue loc-tite wouldn't be a bad idea.

He didn't have torque values off the top of his head but said only that those bolts don't need to be super tight. He said that the 90 degree coolant fitting doesn't need anything more than thread tape. Personally, I wouldn't be comfortable using Teflon tape in such a high-heat area, plus I want a little bit of thread-locking because that fitting isn't torqued down tight when it's facing the right direction.

I'll see what kind of wonder liquids the auto parts store has. **Finally, he said that no one rebuilds wastegate actuators.** -Rich

---

- Bosch Bypass Valve source by Tim Hovey

**Q:** Is the Bosch bypass valve typically available over the counter at any typical parts stores ?

**A:** Yup, any Bosch supplier Bosch P/N 0 280 142 103

---

- Lack of Turbo boost or wastegate clip by Dave Compton

**Q:** I have an 88 XR4ti - right now it's just a plain 4 cylinder. Something has happened to my turbo. When you step on the gas - it goes from minus 15 to 0 - you can tell the turbo isn't working - no power. Any ideas on what the problem might be.

**A:** The clip fell off of the wastegate rod.

Stick your hand below the turbo, follow the rod along from the wastegate diaphragm, and you'll feel that it is just hanging in midair.

Go buy a vacuum brake bleeding kit at PepBoys, about \$35. You need one anyway, if you own a turbo car.

Connect the vacuum hose to the pressure port on the pump. Connect the other end of the hose directly to the diaphragm hose connection on the wastegate. Pump up the pump. This moves the rod out, and allows you to place it back over the tang on the wastegate door. Wrap a paper clip around the tang in it's groove, and then wrap the excess paperclip around the wastegate rod.

Ok, I know this all sounds like so much hoo-hay, but this is usually what it is. Forget trying to find the proper sized c clip, they are difficult to find. And paperclips last essentially forever. I did this very repair on the fairgrounds at the Carlisle show this year, in about 5 minutes.

Now, I know what I'm doing. And you may not be familiar with these terms, but if you go look at the car, you'll get a better understanding of what I'm talking about. If you absolutely, positively must be able to see what you are doing, then look up at the bottom of the turbo from under the car.

Good Luck!

Dave

---

- Boost Control Solenoid by Ryan Mattson

**Q1:** I am trying to understand the how the Boost control solenoid limits the boost. As I see it, the BCS actually controls a "leak" of high pressure compressor discharge air back to the compressor



intake. This leak occurs at the orifice, which is also the high pressure air supply for the waste gate actuator. Is this correct?

**A1:** Yes. Sounds good.

**Q2:** Now my other question is this. The BCS clearly limits boost to about 10psi until the revs hit 4000 RPM. Removing the BCS would allow the boost to go higher sooner. Is there any problem with the higher boost at lower rpms? Is this an Intercooler required type mod?

**A2:** No, as long as you keep things moderate (15/ 16 psi) and run decent gas you shouldn't have any pinging. Though an intercooler is always a good idea.

**Q3:** If the BCS line was completely blocked so the wastegate actuator always saw full discharge pressure does anyone know when full open occurs?

**A3:** The BCS actually never even comes into play on automatic cars and on the manual cars only above 4000. The wastegate actuator as a stand along item, limits boost to 9/10 psi. It serves only to add more boost on the manual cars and above 4000.

---

- What's wrong with my Turbo ? by John (FRMRPRO)

**Q:** The problem I'm having is that the other day on my way home from work I lost boost the car loaded up (ran rich-no boost gee go fig.) I coaxed it home and let it cool off. When I jacked it up there was a linkage that runs from the exhaust side of the turbo to a metal cylinder about 2" in diameter and 2" thick that was snapped. The place it connected to the exhaust side moves freely but where it connects to the cylinder thing is frozen solid anyway I have no idea what this cylinder is but it is visible on the bottom of the turbo from the front (about 5:30 on the turbo). I'm not driving the car, which means I'm using the wife's Mystique till I get it fixed. Help! PS sorry about the book I've just typed. Thanks Wrgrindle

John (Frmrpro) replies:

**A:** That's your waste gate actuator. If the shaft is broken/disconnected, the waste gate would be free to flop open under boost, thus you'd get the symptoms you describe. If the actuator is frozen shut and the shaft still connected, you should be overboosting.

BTW, the WGA is controlled by a vacuum line that opens it when boost reaches 10lbs, or higher if the boost control solenoid overrides the signal and delays it. When you say it was snapped, do you mean the metal shaft actually broke, or its off the pin it should connect to on the turbo waste gate? It should be connected and held in place by a horseshoe-shaped snap ring. Maybe you lost the snap-ring? Regarding it being difficult to move, that's normal. If you hook up a hand-held vacuum/pump to it, and pumped it up to 10psi, you should see the shaft move. It should hold 10psi for at least 10 seconds, and should bleed down to 2psi or so after about 35-40 sec.

Test the WGA first (after you reconnect the shaft, if possible). If NFG, you can pick up a new/rebuilt one from most turbo rebuilders (e.g., Performance technologies in So. CA is very good) for about \$60. Its a little tough to get the bolts out (on compressor) and to drop the oil return line and get it back on, but if you're competent mechanically, it should take about 45min. You don't need to take out anything else (e.g., the turbo itself). On the other hand, if it decides is wants to be a PITA to you, it could take a lot longer than 45 min....,

---

- Turbo bracket, how important to put back ? by Davis Stewart

**Q:** Justin Morgan asked: I cracked the head a few weeks ago. I've got all my new parts in and am in the process of checking the old parts that I broke while removing the head.

**Q1:** Water feed to turbo (side by engine) Is this available or easy to make?

**A1:** Don't know if the waterline is still available from FLM, but you can bend one out of 1/2 soft copper tube. You can also get a brass fitting to replace the steel one that likely got rusted and rounded over getting it out.

**Q2:** Turbo support bar necessary? It was a pain to get the turbo off because of the oil return line running through the support. I cant imagine how I'll get it back on.



**A2:** Yes, the turbo support should be used. It will help avoid ending up with a cracked manifold. Getting it on isn't fun but it's easier if you follow the right sequence:

- 1.) Connect the oil return line to the fitting on the block first. No easy way to tighten it once the support bracket is in place. Make sure it's tight and centered so it doesn't rub against the bracket. Stubby wrenches come in handy here - 7/8 and 3/4 ? Don't connect the upper end of the oil return line to the turbo until after the support bracket is on and the turbo is bolted up.
- 2.) The rod to the wastegate will prevent you from getting the support bracket over the studs. Loosen the bolts holding the wastegate actuator. You can then either unhook the rod from the wastegate or remove the bolts completely and swing the rod over so you can get the support bracket on. Slip the support bracket over the studs and then immediately bolt the lower end of the bracket to the block hand tight. If you don't put the lower support bolt in before you tighten the upper support nuts, guaranteed the hole in the bracket won't be lined up with the hole in the block!! Then put the nuts on the lower turbo studs.
- 3.) Reconnect the rod & actuator. Don't forget the C clip if you took the rod off. Make sure the lower end of the coolant line tube in the hose. Use silicon hose if you are replacing the old one. Bolt the turbo up tight. Connect the upper end of the oil return to the turbo using a new gasket. Connect the upper end of the coolant return to the turbo. Tighten the lower end of the lower coolant line and the lower support bracket bolt. Install the upper coolant tube.

Getting the turbo nuts on and off can be made a little bit easier if you pick up a 15mm - 6 point combination wrench at Sears. The box end is 6 points, big help if any of the nuts are rounded over. The 6 point combo is also shorter than the standard 15mm combo giving you a little more swing room.

- 
- What's part number for turbo gasket set ? by Tom Manship

Q: Felpro p/n ES72811 "Turbo Mounting Kit". My local Felpro dealer only charges \$5.04 for this one, and they'll have it for me Monday morning. I probably got the one before (~3 years ago) from Kragen Auto Parts, which is also a Felpro source...

- 
- Proper Bypass Valve Direction ? by Don

Q: What is the proper direction to pipe up the Bosch bypass valve ? by Don

**A:** This is how my Bosch valve works that I got from Allan Slocum.

OK, First get a vacuum pump and hook it to the nipple on the bypass valve. Pull a vacuum and see if you can blow through it. See if you can blow through it without the vacuum on it. Ok, now you know when it bypasses air and when it doesn't.

The bypass valve is hooked up to engine vacuum. The engine has vacuum when you are cruising but none if you are accelerating. When the engine is under boost the bypass valve should be closed to air passing through it. When you are not boosting the valve should let air go through it. The valve doesn't care which way the air is moving(sort of) but if it's hooked up the wrong way the boost pressure could open the valve by itself and you would lose boost. That would all depend on how strong the spring is that is inside of the bypass valve. I would think that you would hear and feel it.

The valve should be hooked to two hoses, one before the turbo and one after. When you floor the accelerator and create boost the engine loses all vacuum. The valve has no vacuum now so it should be closed. As soon as you let off the gas the vacuum gauge shows high vacuum. This vacuum should open the valve and let the air go back through the hose that is before the turbo inlet somewhere. This reduces the pressure on the compressor wheel of the air trying to go back into it. It also helps the turbo to continue spooling because you are not slowing down the compressor wheel.

- 
- Waste Gate Actuator R&R ? by Preston Anderson

Q: What is involved in removing and replacing the waste Gate Actuator ?

A: I'm currently on my 3rd (used) WGA this year. All were changed while on the car. Here's how I did it. With a little practice you can do this in 15-30 minutes.

#### Disassembly

1. Drive car up on ramps (ok this is obvious). Use a jack and stands if you desire.
2. Unbolt the oil return line from the bottom of the turbo and move aside (10mm socket with lots of extensions). This will need to be out of the way in order to remove one of the 2 WGA attaching bolts (13mm?).
3. Remove the clip holding the actuator rod to the wastegate (you'll want to have a spare clip or 2, they tend to fly off sometimes or just break. Standard "E" clips from the hardware store seem to work just fine for replacements. Don't take the actuator rod off yet.
4. Unbolt the WGA. The bolt on the bottom side comes off easily from under the car. The other can be done with some difficulty from on top of the motor. An angled (moon) wrench really helps here. As you loosen these bolts the actuator rod tension (preload) will be released and the rod will just fall off the wastegate shaft.
5. Disconnect the vacuum line to the WGA. You will likely need to replace this line due to deterioration from the heat. The now free WGA can be removed by pushing the frame of the WGA down and rotating it away from the compressor housing. Do this from above. It comes out under and in front of the compressor housing moving towards the A/C compressor. This is the hardest part of the job.

#### Reassembly

Pretty much the reverse of the above. Just remember to attach the actuator rod to the wastegate shaft before you snug up the bolts holding the WGA to the compressor housing. Alternately you can use a "mighty vac" to pressurize the WGA to allow the end of the rod to slip on the wastegate shaft. Be sure to clean the gasket off the oil return line and turbo. I have just used high temp silicone to seal the bottom oil line to the turbo (don't need no stinkin' gasket).

- 
- Rebuilt Centre section for Turbine ? by Brad Anesi

Q: What is a good source for rebuilt Turbocharger center sections

A: You can also get a complete center section for \$125 from [BamaBev78@aol.com](mailto:BamaBev78@aol.com) <<mailto:BamaBev78@aol.com>> I know some on this list have been happy with these.

Considering the potential challenges in removing wheels, this seems like a pretty good deal to me. Of course, I know all too well that removing a turbine housing can sometimes be a challenge, so this isn't necessarily a lay-up.

**A2:** Bev works for MJM auto parts inc. in Buhl, AL. phone no. 1-205-339-0616. I bought a cartridge a year ago on ebay for 95.00, [raised min. bid now]. They must be fairly big outfit, they sell to a lot of turbo rebuild shops in my area. There is no warranty, but good cheap way to get better turbo

- 
- How the Boost Control works by Jack Newman

The wastegate opens at whatever boost pressure the controlling device is set for. If you are driving an automatic with the stock BCS (Boost Control Solenoid), it opens the wastegate at about 10 psi. Manual is about 14 psi, yellow butt-splice in the line (BCS disconnected) is about 15 psi, and a Gillis valve can be set to as low as 8 to as high as you dare. If the wastegate is bad (usually a hole in the diaphragm) it won't open, so boost will go much too high (warning buzzer at 17 psi) and blow up your motor. I suppose a wastegate actuator could get stuck somehow in the open position, which would bleed exhaust gasses past the turbine, which would kill the hell out of your boost. Wastegate actuator is mechanical, system pressure operated. BCS is an electrically controlled leak, EEC controlled. Gillis valve is a manually adjustable, controlled leak, which you can set to open where you wish.

Bypass valves (and Blowoff valves) are devices between the turbocharger compressor outlet and the throttlebody inlet. Their primary purpose is to protect the system from pressure surges. Consider a car under serious acceleration; let's say in third gear. As we approach the shiftpoint, boost is constant at the maximum (my car, 16 psi). shiftpoint. Lift right foot, down left foot, shift, up left foot, down right foot. When you made that first move, the throttle plate went from wide open to dead shut, and the air blasting through it came to a full stop, then bounced back, hard, at the compressor wheel. At the least, it will slow down the compressor, so you don't have max boost for acceleration now in fourth gear. At the worst, that back surge can actually bend or even break the blades in your turbocharger. To prevent this problem we bypass or blowoff. ("Bypass" = back to intake side of compressor, "Blowoff" = dump to outside.) When the B valve detects the pressure change at the throttle body, it opens. Some of the high pressure air is vented. This protects the turbocharger from surge stress, and permits the shaft to continue spinning at speed. This gives much faster boost response when we reach the last step of that shift, right foot down.

Blowoff valves are probably easier and cheaper to build, but really aren't that good for our kind of system. We use measured volumes of air to compute fuel supply, along with several other engine parameters (timing!). If we dump part of that air, we have changed the volume after it has been measured by the VAM. Not good, so we Bypass. This takes the air from up by the throttle body and puts it back in the line between the VAM and the compressor intake. We still have the same measured volume, and I suppose it could even (v.sl. pressure rise) help keep the turbine speed up.

I realize these are somewhat simplistic descriptions of some very complex actions inside our engines, but hopefully the basic ideas will come across understandably.

- Wastegate Actuator Source by Steve Roberts

**Q:** Someone mentioned there is someone selling working wastegate actuator's in the area of \$50-\$60. Does anyone know where this is from or have the contact information? BAT sells them for \$95+\$30core charge.

**A:** On Steve Kummerfeldt's suggestion, I bought an actuator from Turbo City. Cost was \$95. p/n 700-120. Adjustable rod type. These are new units, not remanufactured. No core required. It is the same OEM used with Garrett. Works fine.

**Turbo City 714 639 4933. Located in Orange (LA) CA.**

**A2:** Rob in Santa Barbara also said he contacted Gary at Turbo City in Orange, CA. (714) 639-4933. The price is normally \$95 plus shipping for a new WGA (not remanufactured) with an adjustable rod. I spoke to Gary and told him I was referring this to the IMON list and he indicated that he would honor a discounted price of \$80.00 for the group. Not bad.

- Wastegate Actuator on car Replacement by Steve Roberts

**Q:** It doesn't look to me there is an "easy" way to replace the actuator ??

**A:** I just replaced the WGA on my '85 a month ago. You don't have to take off a bunch of stuff. Raise the front of the car on stands. Get a drop-light. Then:

1. Remove the rod circlip, and don't lose it!
2. Remove the two bolts which mount the WGA body.
3. Remove the two bolts which hold the oil return tube to the bottom of the turbo assembly.
4. Now, by fiddling around you can snake the WGA out. It can be a bit tedious, but you can do it.

- Turbocharger Oil Feed Line by Brad Anesi

For \$50, you can get one from Motion Dynamics. Just click below and go down about 2/3rd of the way to the heading labeled "Oiling". Lots of other 2.3 specific stuff available on this page.

<http://www.motion-dynamics.net/products/2point3/default.asp>

Jim Whelan is the owner - good guy - let him know you're a "Merkur guy" as Jim has sponsored the Carlisle event with product donations in past years.

---

- Why use an External Turbocharger Wastegate by Timothy Spencer

For turbo efficiency, an external is better, but an internal wastegate is more efficient than an external. You may be confused right now. You need a larger diameter external wastegate to flow the same as an internal. An external allows you to put a larger diameter free flowing exhaust right after the turbo. This makes for quicker turbo spool-up and more power. You must also match the wastegate size to the engine flow. Many of the center mount headers come with 46mm wastegate flanges. That's overkill for most 2.3s. You not only spend a lot more you also have very erratic boost levels. Now for adjusting the pressure, get adjustable valving for the wastegate. It may take 5lbs of pressure to start moving the actuator. If you make it harder for that pressure to get to there, then you get more pressure from the turbo. So making it adjustable is the key, or setting the correct pressure and leaving it by changing the orifice size of the fitting going to the actuator hose.

## Upgrade Paths (recommended upgrades)

---

- What do I do to get more power ? by Richard Thompson and others

**Q:** I have a 1987 XR4Ti. It is in mint shape inside and out. This is actually my second one , I had a 85 a few years back. That 85 just zipped along it had the 5 speed transmission. My 87 has the 3 speed auto. It runs awesome but can't make use of all the power with the 3 speed. The car is stock it has no modifications done to the engine. I've heard that a 302 or 5.0 will drop into it with a little bit of work. If and when the engine craps out what would be your suggestions on a engine. Should I rebuild the 2.3L that I have or install a 5.0. I would redo the 2.3 if I had a 5 speed transmission. I was just curious what all i could do to my car to hop it up a little without costing a whole pile of money. I'd appreciate any advice you have to offer. Thanks from Dean

**A:** Dean, The V-8 conversion is not just a drop in proposition at all. It ends up being very expensive since you have to change mounts, radiator, wiring, driveshaft length, front springs, etc... I would without question recommend "souping up" the 2.3l engine instead. There are tons of cool modifications that you can do to it that can give it V-8 power, with 4-banger mileage and weight. I would suggest the following steps, in this order.

- 0. First get it in tune and running right. The following mods. are a waste of money without fresh plugs and wires, no computer trouble codes, nice idle, etc...
- 1. Install a 2 1/2" or 3" diameter exhaust from the turbo back. Buy a 3" downpipe from [www.sacramentomustang.com](http://www.sacramentomustang.com) (buy the cheaper of the two) and have a muffler shop start with it as a basis for the exhaust. Add a high flow catalytic converter and a Borla (or other) muffler. This will help mileage and really cut down on turbo lag. This is the best bang for buck change in drivability.
- 2. Do the K&N filter thing. You can buy a drop in replacement air filter for the 2.3 turbo.
- 3. Do an intercooler. I, of course, think that my air/water intercooler is the best choice, but there are tons of ways to skin that cat. This helps power and cuts down on the heat reaching the engine.
- 4. Turn up the boost pressure. (don't do this till you have done number 3 above.) Without the intercooler, detonation/pinging (if it were really, really bad) could destroy the engine if you are not careful.
- 5. Swap in the LA3 computer and larger air-meter from the '87/'88 Ford Thunderbird Turbocoupe.
- 6. Add an adjustable fuel pressure regulator to keep it rich at high boost, high RPM.
- 7. Add a Walbro 255 lph. fuel pump.
- 8. Change the cam, used ford ranger roller cam can be had for pretty cheap \$70 or so.
- 9. Take of the intake manifold and port it, then put it back on.
- 10. Take off the exhaust manifold and port it, then put it back on.

At this point, it should be around 250 hp and would be a real monster. Just doing steps 1-3 totally changes the feel of the car. You would definitely want to change out the stock automatic for a T-5 transmission, since the stock auto could likely be toast by step 3 or four.

Forget the V-8. Richard Thompson

## Wheels and Tire Information

---

- 88-89 wheel lock keys by Dave Compton

Turns out that Steve Walton already has these made and is selling them, for \$4.50 delivered, no less!

Contact him at [swalton@infi.net](mailto:swalton@infi.net)

---

- Wheel Bolt patterns and Offsets by Dimitri <--- goofing off at work!

Guys,

I've never seen a one stop location for this stuff, so I figured I'd post it. I've been doing some research on wheels, suspension, and brakes for TurboTwo, and came up with info on some of the brands that have been mentioned as alternatives. This info should be useful in searching for wheels and for engineering brake conversions. The offset figures apply to stock size wheels. This info is geared mostly towards Scorpions for obvious reasons :)

XR:

Bolt pattern: 4x108 (yeah yeah, everyone knows that)

Wheel Center Bore: 63.3mm

Acceptable offset: 35-38mm

Scorpio:

Bolt Pattern: 5x112 (that's 5x4.4 in SAE)

Wheel Center Bore: 63.3mm

Acceptable offset: 35-38mm

Note that with the exception of the bolt pattern, the Scorpio is identical to the XR. Scorpions also have identical front brakes, which means that any brake system engineered for an XR will also work on a Scorpio once the bolt pattern situation is worked out (re-drill, adapter, spindle swap)

Now for alternatives:

Ford Mustang Cobra:

Bolt Pattern: 5x4.5"

Wheel Center Bore: 70.5mm

Offset: 30mm

Jim DeBerry has mounted Cobra wheels both to his XR and his Scorpio. He's also done the PBR Cobra/Vette brakes. Not sure of the details but I will look into this further.

Audi (All late model except TT):

Bolt Pattern: 5x112

Wheel Center Bore: 57.0mm

Offset: 35-42mm

Mercedes (Nearly all C,E,S class):

Bolt Pattern: 5x113

Wheel Center Bore: 66.5mm

Offset: 35-42mm

---

- XR4Ti Front Wheel Bearing Replacement by Stephen Roberts

DISCLAIMER: Reading this looonnnnggggg post may well result in incurring the wrath of the Merkur gods. If you are concerned about this possibility, please stop reading now.

This report is about replacing a front wheel bearing on my '85 XR4Ti while leaving the spindle carrier in place on the car. I have read many posts on the list about this job, and I realize the

consensus is to do this job on the bench after removing the spindle carrier from the car. This was going to be my approach also, until...

As I started the job, two things occurred to me. First, I didn't really want to remove the lower ball joint, and second I don't have a very hefty vise that I thought would support 230 lb-ft of torque. I decided to tempt the fates, and try and do the job with the spindle carrier on the car. In my mind the advantage would be that the carrier would be well supported while applying the torque required to remove and replace the stub axle nut. Following are the steps I used to complete the job.

#### BEARING REMOVAL:

1. I raised the front end and supported it on 2 jack stands.
2. I removed the wheel, removed the brake caliper and wired it up out of the way. I removed the brake caliper mounting bracket, and then pulled off the brake rotor.
3. I disconnected the tie rod end at the spindle carrier. I used the "whacking" method, which consists of removing the cotter pin, backing off the castellated nut 3-4 turns, and then whacking the "ear" of the spindle carrier where the tie rod conical fitting goes through. After a couple of whacks with a 5 lb sledge, the tie rod end popped loose. The idea is that you just shock it enough to break the compressed conical fit. I use this method a lot, and it works really well for me. I don't like the "pickle fork" approach because you tear the rubber grease seal. If you have the special tool to push the tie rod end down through the spindle carrier ear (I don't) that would work also.
4. I removed the pinch-bolt securing the spindle carrier to the front strut, and slid the spindle carrier downwards along the strut about 3/4". Not off the end of the strut, but just enough to allow you to fit the socket on the axle nut later.
5. I popped off the axle nut cover at the inside of the spindle carrier, first using a small chisel to start the cap coming off, and then using a screw driver to pry it the rest of the way off.
6. Using two opposing wheel studs, I bolted on a 3 ft length of angle iron to hold the stub axle from turning. The end of the angle iron rested on the floor of the garage.
7. I used a 1-5/8" socket (3/4" drive) and breaker bar to loosen and remove the axle nut. This was the right side of the car, so the nut has left-handed threads.
8. After removing the nut, I slid out the stub axle. I then reached around the back and took out the inner roller bearing.
9. With a small drift I carefully tapped out the bearing races from the spindle carrier, using the drift and a 5 lb sledge. When tapping out the outer race, this will also dislodge the outer bearing and grease seal.
10. I cleaned the spindle carrier with a wire brush to remove caked-on road dirt, and cleaned out the inside of the carrier where the new bearings would go.

The old bearings and races were both a bit galled, and I could see flakes of metal in the bearings. After cleaning everything, I was now ready to install the new bearings and grease seal. I went to Autozone, where I bought two bearings (the inner and outer are the same bearing). The bearings were Timken part number SET24 (\$10.95 each). I also got a grease seal, Timken part number 3743 (\$4.59).



## BEARING INSTALLATION:

1. With my finger I put a very light coating of grease on the spindle carrier interior where the bearing races would fit. Using the drift, I carefully tapped in the outer bearing race, working repeatedly around the bearing and not hammering too much in any one spot. Continually tapping with the drift and hammer, the race finds it's way "home". Arrival is detected by the sudden very solid feel when hammering.

2. As in the previous step, I tapped in the inner bearing race.

Be sure both races are fully in the home position against the shoulder. Correct bearing operation depends on the exact position of the bearings.

3. I greased the bearings using STP "Hi-Temp Disc Brake Bearing Grease", STP part number SL3161. I put a lump of the grease in the palm of my hand, and then repeatedly pushed the bearing into the grease until I saw the grease coming up through the rollers. I did this working around the whole circumference of the bearing.

4. I placed the outer bearing in place in the spindle carrier.

5. I put some grease on the grease seal, and then installed it in the spindle carrier, using the drift and hammer and tapping round and round like with the bearing races.

6. I slid the stub axle in through the outer seal and bearing.

7. I then took the inner bearing and pushed it into place over the stub axle. I threaded on the axle nut to push the bearing onto the axle. I then took the nut back off.

8. I slid on the splined washer (make sure the washer splines engage the splines on the axle) and threaded on the axle nut. I reused the old axle nut (I know...).

9. I re-oriented the angle iron against the floor to stop the axle from turning. I then tightened the axle nut using the breaker bar and 1-5/8" socket. To apply the 202-232 lb-ft of torque (manual page 11-16-9), I used the following procedure: First I oriented the breaker bar to be horizontal. I weighed myself (182 lbs). Then I did the calculation  $182 * X = 215$ ;  $X = 1.18$ , so I put my foot so as to give a lever arm of about 1.2 feet (about 1 ft 2-1/2"). Then I stood on the breaker bar, positioning it to be pretty level. I stood on it several times. Should be about the right torque.

10. I rotated the axle by hand. It turned smoothly without any sign of binding or roughness.

11. I tapped on the rear dust cap, reinstalled the brake rotor and caliper, and reattached the tie rod end.

## JOB DONE.

I know, I know, this is not the recommended procedure. And maybe I'll get my just "reward" from the Merkur gods for daring to do it this way. But, the job went very smoothly and appeared to go together just fine. I'll see how this goes and report if I have problems with the wheel bearings as time goes on.

This may also be heresy, but I feel the torque on the axle nut is not particularly important. You want it to be pretty darn tight of course, but it seems to me the setup of the bearings and their clearance or preload and whatnot is determined by the machining tolerances of the spindle carrier and the bearings themselves, and that you mainly need to be sure the outer bearing races are fully "homed" when tapping or pressing them into the spindle carrier. Once that's done, the rest depends on the machined tolerances, and you just want the axle nut to tighten everything into it's

final position. Just my opinion of course, and again I'm probably foolishly flaunting this in front of the Merkur gods.

---

- New Source for Compact Spare Tire by Brad Anesi

**Q:** Anyone know a source for the temporary spare tire for the XR4Ti. Yesterday, I found the one in my 88 model basically "dry rotted". The tire looks like it had a blowout.

**A:** Your best bet is going to be sourcing a complete spare from a junkyard Contour or Mystique. The tire OD is a little bigger than the stock XR spare, but it just barely fits in the spare well. A Focus should also work as a donor, but I don't know for sure.

Just bear in mind, neither the stock spare nor Contour will fit over most "big brake" upgrades, so if you blow a front tire, you'll have to swap your rear tire to the front and put the spare on the rear.

At this point, everyone should be pro-actively replacing their spare tires if they haven't already.

They are now 15 to 20 years old, and the quality of the tires Ford of Europe used was just horrible. When I had to use my original spare ~4 years ago, it lasted about a mile before delaminating and completely coming apart.

---

- Wheel Lug Torque Settings are Incorrect in manual by Roland Zuk

NOTICE: There may be an error in the wheel torque specs in your copy of the XR4Ti Shop Manual. In my copy, Rev 11/88, the Group 11 Specifications page lists wheel lug nut torque as 100-144 N-m and 75-101 lb-ft. THIS IS INCORRECT.

The maintenance Section 11-17 lists **wheel nut torque as 70-100 N-m and 55-70 lb-ft. THIS IS CORRECT.** (The actual conversion from metric is 52-73 lb-ft if you're particular)

Check your manual and make any necessary corrections. While you're at it, it would be a good idea to write the torque values in your Owner's Manual as well. They were not included in the Owner's Manual by Ford.

---

The Scorpio Shop Manual correctly lists wheel nut torque as 70-100 N-m and 52-73 lb-ft.

---

This came to light today as I was installing new studs on my XR to accommodate a revised race wheel setup. I should have realized the 100 lb-ft number was wrong, but not before I created some nice necked-down tensile test specimens.

If you've been over-torquing your wheel studs, it would be a very good idea to replace them for safety's sake. Due to normal variations in manufacturing lengths, I don't think inspecting/measuring existing studs would be a reliable assessment of whether they've been stretched.

I believe replacement studs are available from Ford. FYI, the OE stud measurements are 12mm 1.5, 12.95mm knurl dia, 15mm shoulder length, 38mm overall length.

As an alternative to OE Ford, there's a Mazda car/Ranger truck stud that fits well. Available in aftermarket. 12.95 knurl, 12.7 shoulder, 42.4 overall. The NAPA part number is 641-2197. This stud has the advantage of giving an extra 3-4 threads of engagement on the front wheels over the OE part, which IMO is probably okay for normal street driving, but too short for spirited motoring peace of mind.

## INDEX

<u>Topic</u>	<u>Chapter</u>
A-Pillar	<a href="#">Interior</a>
ABS Module clicking (Scorpio)	<a href="#">Brakes and Upgrades</a>
Air Distribution Control Motors	<a href="#">Air Conditioning</a>
Alignment, Front End	<a href="#">Steering</a>
Alternator, 3G	<a href="#">Electrical</a>
Alternator, Charging light	<a href="#">Electrical</a>
Antenna	<a href="#">Sound System</a>
Anti-Slosh Board	<a href="#">Fuel System, Sensors</a>
ATF Flushing	<a href="#">Automatic Transmission</a>
Auxiliary Shaft	<a href="#">Car Won't Start</a>
Barometric Air Pressure (BAP)	<a href="#">Troubleshooting, Sensors</a>
Battery Light	<a href="#">Electrical</a>
Belt, serpentine	<a href="#">Dual plug conversion</a>
Belt, Timing	<a href="#">Engine</a>
Blower Motor	<a href="#">Heating</a>
Boost Control	<a href="#">Turbocharger</a>
Boost, lack of	<a href="#">Turbocharger</a>
Bolt Pattern and Offset	<a href="#">Wheels and Tires</a>
Brake Caliper Paint	<a href="#">Brakes and Upgrades</a>
Bulbs, Scorpio License plate	<a href="#">Body- Electrical</a>
Bushing, Rear Beam	<a href="#">Suspension</a>
Buying a Merkur	<a href="#">Buying a Merkur</a>
Bypass Valve	<a href="#">Turbocharger</a>
Camber Adjustment Shims	<a href="#">Suspension</a>
C-3 Automatic Transmission	<a href="#">Automatic Transmission</a>
C-4 Bell Housing	<a href="#">Transmission Conversions</a>
Charging System, Testing	<a href="#">Electrical</a>
Clutch, Aftermarket	<a href="#">Transmission and Clutch</a>
Clutch Cable Issues	<a href="#">Transmission and Clutch</a>
Codes, Engine	<a href="#">EEC-IV Codes</a>
Compression test	<a href="#">Engine</a>
Condenser Fan, Scorpio	<a href="#">Air Conditioning</a>
Computer, Engine	<a href="#">EEC-IV Codes</a>
Cooling fan	<a href="#">Cooling System</a>
Crankshaft Pulley, 3-Groove	<a href="#">Air Conditioning</a>
Cylinder head, repair	<a href="#">Engine</a>
CV Joint Bolts	<a href="#">Diff-CV Joints</a>
Defroster, Troubleshooting	<a href="#">Body- Electrical</a>
Differential Lube Oil	<a href="#">Diff-CV Joints</a>
Dipstick	<a href="#">Engine, Intake Side</a>
Distributor Shaft	<a href="#">Car Won't Start</a>
Distributor Troubleshooting	<a href="#">Engine</a>
Distributorless Ignition	<a href="#">Dual plug conversion</a>
Door Panels	<a href="#">Interior</a>
Door Chime, Taurus	<a href="#">Merkur Miscellany</a>
Driveshaft Length	<a href="#">Driveshaft and Guibo</a>
Dual Plug cylinder head	<a href="#">Dual plug conversion</a>
Engine Grounds	<a href="#">Troubleshooting</a>
Engine Specs	<a href="#">Engine</a>
Emissions Testing	<a href="#">Troubleshooting</a>

Exhaust Manifold Gasket	<a href="#">Engine</a>
Exhaust Manifold, Glowing	<a href="#">Exhaust System</a>
Fender, Liner	<a href="#">Body</a>
Fender, replacement	<a href="#">Body</a>
Fire	<a href="#">Safety Issues</a>
Fuel Injector Cleaning	<a href="#">Fuel System</a>
Fuel Injectors, O-Ring	<a href="#">Fuel System</a>
Fuel Pressure Regulator	<a href="#">Fuel System</a>
Fuel Pump, Relay	<a href="#">Fuel System</a>
Fuel Pump, Replacement	<a href="#">Fuel System</a>
Gaskets, Intake	<a href="#">Intake Side</a>
Gauge, Fuel	<a href="#">Fuel System</a>
Guibo	<a href="#">Driveshaft and Guibo</a>
Half-shaft Lengths	<a href="#">Diff-CV Joints</a>
Hatch, rattling	<a href="#">Body</a>
Hatch won't lock	<a href="#">Body</a>
Head Bolts	<a href="#">Engine</a>
Headliner repair	<a href="#">Interior</a>
Headlight, Euro Scorpio	<a href="#">Body- Electrical</a>
Headlight, Polishing	<a href="#">Body- Electrical</a>
Heater Core	<a href="#">Heating</a>
Heater Valve	<a href="#">Heating</a>
HID, Plasma Headlights	<a href="#">Body- Electrical</a>
Idle, High	<a href="#">Troubleshooting</a>
Idle, Sticking	<a href="#">Troubleshooting</a>
Ignition key, broken	<a href="#">Miscellaneous</a>
Inertia Switch	<a href="#">Body- Electrical</a>
Instrument Cluster, Scorpio	<a href="#">Body- Electrical</a>
Jump Starting	<a href="#">Safety</a>
Key, Codes	<a href="#">Body</a>
LA2 Computer	<a href="#">Ignition and EEC</a>
Lucas Power Steering additive	<a href="#">Steering</a>
Manual, Service	<a href="#">Merkur Miscellany</a>
Merk Meter	<a href="#">Sensors</a>
Mirror, Rear View	<a href="#">Interior</a>
Model Year Changes	<a href="#">Miscellaneous</a>
Motor Mounts	<a href="#">Engine</a>
Oil Leaks	<a href="#">Engine</a>
Oxygen Sensor	<a href="#">Sensors, Exhaust System</a>
Paint, touch up	<a href="#">Body</a>
Part Number Decoding	<a href="#">Merkur Miscellany</a>
PBR Brake Upgrade	<a href="#">Brakes and Upgrades</a>
PCV upgrade and testing	<a href="#">Intake Side</a>
Pistons, marking of	<a href="#">Engine</a>
Power Steering Pump	<a href="#">Steering</a>
Power Window Fix	<a href="#">Body- Electrical</a>
Pressure, Fuel	<a href="#">Fuel System</a>
R-12 or R-134	<a href="#">Air Conditioning</a>
Radio Repair parts	<a href="#">Sound System</a>
Radiator, Cap	<a href="#">Cooling System</a>
Radiator, Fan	<a href="#">Cooling System</a>
Radiator, Sources	<a href="#">Cooling System</a>
Ranger Valve cover gasket	<a href="#">Engine</a>

Rear Disk Brake Conversion	<a href="#">Brakes and Upgrades</a>
Rear Window Wiper repair	<a href="#">Body- Electrical</a>
Recirculation Door	<a href="#">Heating</a>
Recommended Upgrades	<a href="#">Upgrade Path</a>
Relays, Clacking	<a href="#">Electrical</a>
Rotoflex Coupling	<a href="#">(see guibo)</a>
Running Rich	<a href="#">Troubleshooting</a>
Scorpio (various Issues)	<a href="#">Scorpio Stuff</a>
Sensor, BAP	<a href="#">Troubleshooting</a>
Sensor, Coolant (purple ring)	<a href="#">Sensors</a>
Serpentine Belt	<a href="#">Dual plug conversion, Engine</a>
Service Manual	<a href="#">Merkur Miscellany</a>
Solenoid, Outside Air	<a href="#">Heating</a>
Spark Plugs	<a href="#">Engine</a>
Spark Plug Wires	<a href="#">Engine</a>
Speed Bleeders	<a href="#">Brakes and Upgrades</a>
Speed Sensor	<a href="#">Transmission and Clutch</a>
Speedometer Troubleshooting	<a href="#">Body- Electrical</a>
Speedometer Gears	<a href="#">Transmission Conversions</a>
Start, car won't	<a href="#">Car wont start</a>
Starter Solenoid	<a href="#">Troubleshooting</a>
Steering Rack, leaking	<a href="#">Steering</a>
Steering Wheel, removal	<a href="#">Body, Steering</a>
Struts, Aftermarket	<a href="#">Suspension</a>
Taurus Door Chime	<a href="#">Merkur Miscellany</a>
T-5, Conversion to	<a href="#">Transmission Conversions</a>
T_5, Identification	<a href="#">Transmission Conversions</a>
T-9 heat shield	<a href="#">Transmission and Clutch</a>
T-9 Hard into Reverse	<a href="#">Transmission and Clutch</a>
T-9 Transmission Removal	<a href="#">Transmission and Clutch</a>
Tank, Fuel	<a href="#">Fuel System</a>
Tachometer Repair	<a href="#">Electrical</a>
Taillights, Crazy	<a href="#">Body- Electrical</a>
Throttle Position Sensor (TPS)	<a href="#">Sensors</a>
Thunderbird Turbocoupe	<a href="#">Junkyard Strategies</a>
TFI module	<a href="#">Ignition and EEC</a>
TFI module, repeated failures	<a href="#">Ignition and EEC</a>
Timing Belt	<a href="#">Engine</a>
Timing, Cam	<a href="#">Engine</a>
Timing, Ignition	<a href="#">Ignition and EEC</a>
Tire, Spare	<a href="#">Wheels and Tires</a>
Torque Converter, Draining	<a href="#">Automatic Transmission</a>
Trouble Codes	<a href="#">EEC-IV Codes</a>
Troubleshooting starting	<a href="#">Car wont start</a>
Trunklid won't open, Scorpio	<a href="#">Scorpio Stuff</a>
Turbocharger, rebuilding	<a href="#">Turbocharger</a>
Turbocharger, troubleshooting	<a href="#">Turbocharger</a>
Turbo bracket	<a href="#">Turbocharger</a>
U-Joints	<a href="#">Driveshaft and Guibo</a>
Turn Signal Bulb, Scorpio	<a href="#">Body- Electrical</a>
Vacuum Modulator	<a href="#">Automatic Transmission</a>
Valve Cover Gaskets	<a href="#">Engine</a>
Valve Cover	<a href="#">Engine</a>

Valve, Positive Crankcase Vent	<a href="#">Intake Side</a>
Vane Air Meter	<a href="#">Intake Side</a> , <a href="#">Troubleshooting</a>
VIN decoding	<a href="#">Body</a>
Walbro Fuel Pump Install	<a href="#">Fuel System</a>
Warning Light, Crazy	<a href="#">Electrical</a>
Wastegate actuator	<a href="#">Turbocharger</a>
Wastegate Clip	<a href="#">Turbocharger</a>
Weight Distribution, F/R	<a href="#">Suspension</a>
Wheel Bearings	<a href="#">Diff-CV Joints</a> , <a href="#">Wheels and Tires</a>
Wheel Locks and Keys	<a href="#">Wheels and Tires</a>
Wheel, Rear Cylinders	<a href="#">Brakes and Upgrades</a>
Wheel Studs	<a href="#">Diff-CV Joints</a>
Window Switches, Cleaning	<a href="#">Body- Electrical</a>
Windshield Wipers, Slow	<a href="#">Body- Electrical</a>
Wires, spark Plug	<a href="#">Engine</a>
Years Made	<a href="#">Merkur Miscellany</a>

GO TO: [TABLE OF CONTENTS](#)