

Wiring diagram for Sierra (RS) Cosworth 4x4 (taken from dutch training documentation).

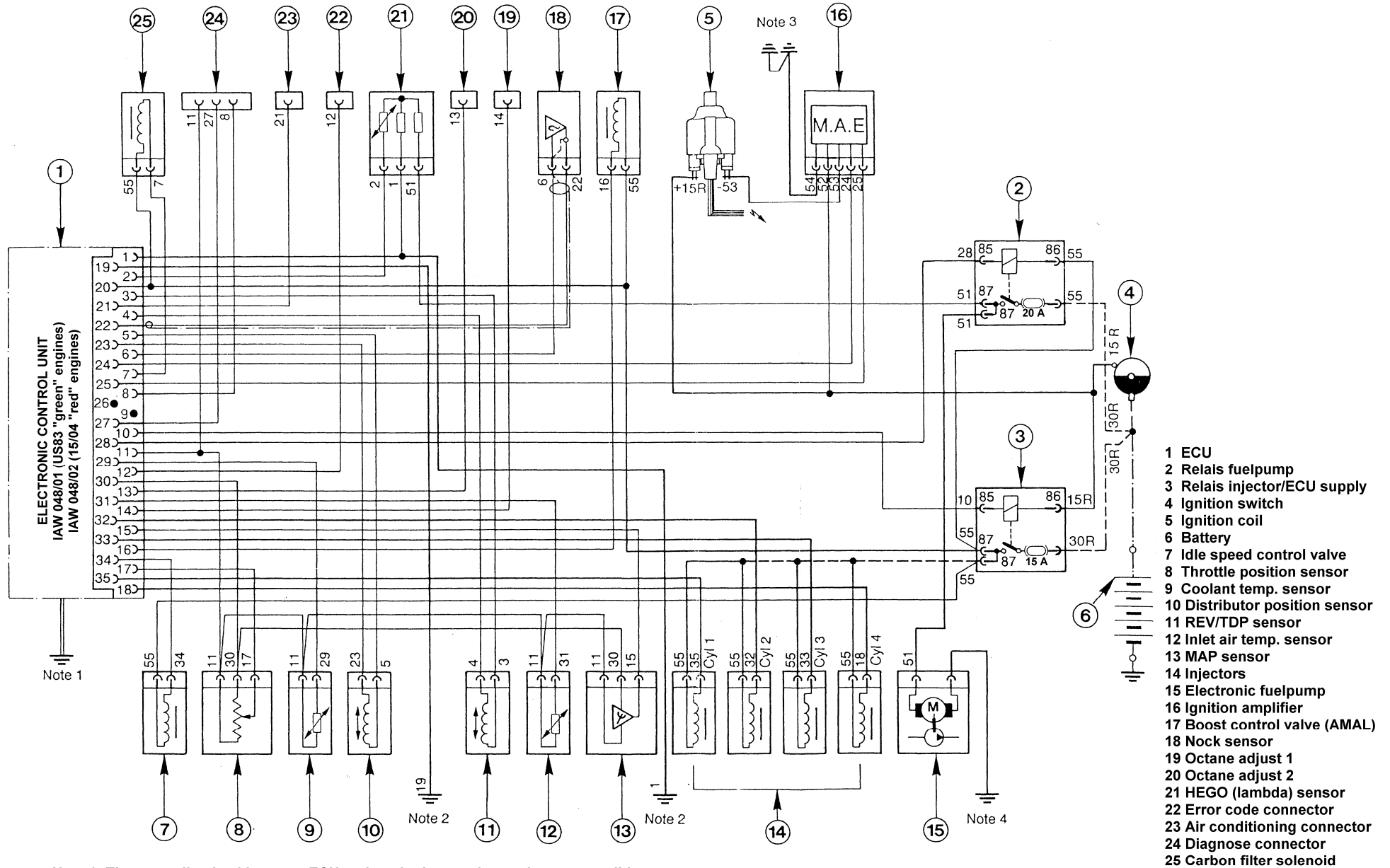

Note 1: The grounding lead between ECU and car body must be as short as possible.

Note 2: ECU grounding points 1 and 19 are connected to different locations on the engine.

Note 3: Connect this grounding lead to MAE cooler first and from there to engine grounding point.

Note 4: Grounding point on car body.

General note: HEGO-sensor (21, lambda sonde) and carbon filter solenoid (25) are not used on 15/04 "red" engines.