

33-08-001 , Anti-theft Alarm

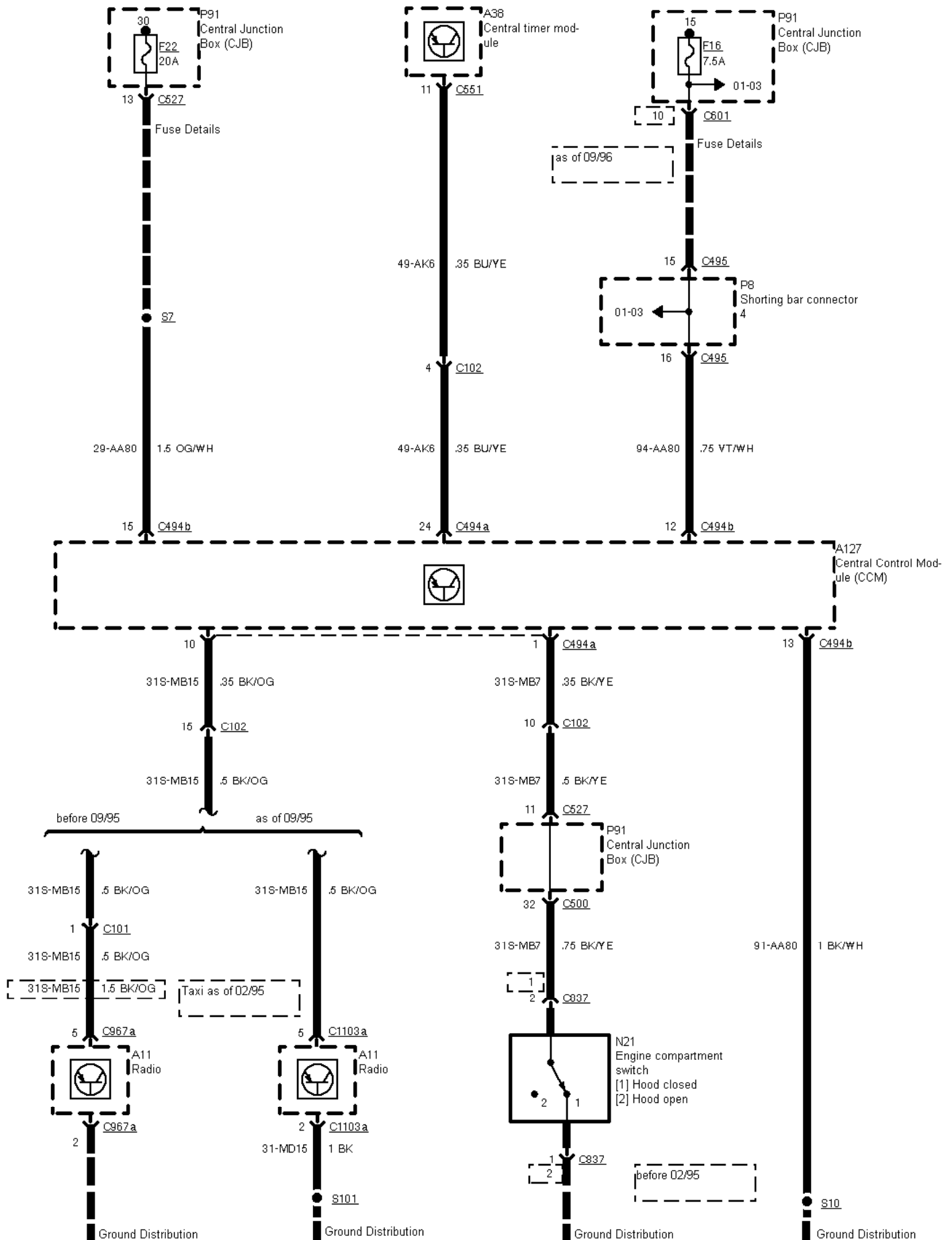

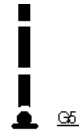

33-08-002 , Anti-theft Alarm

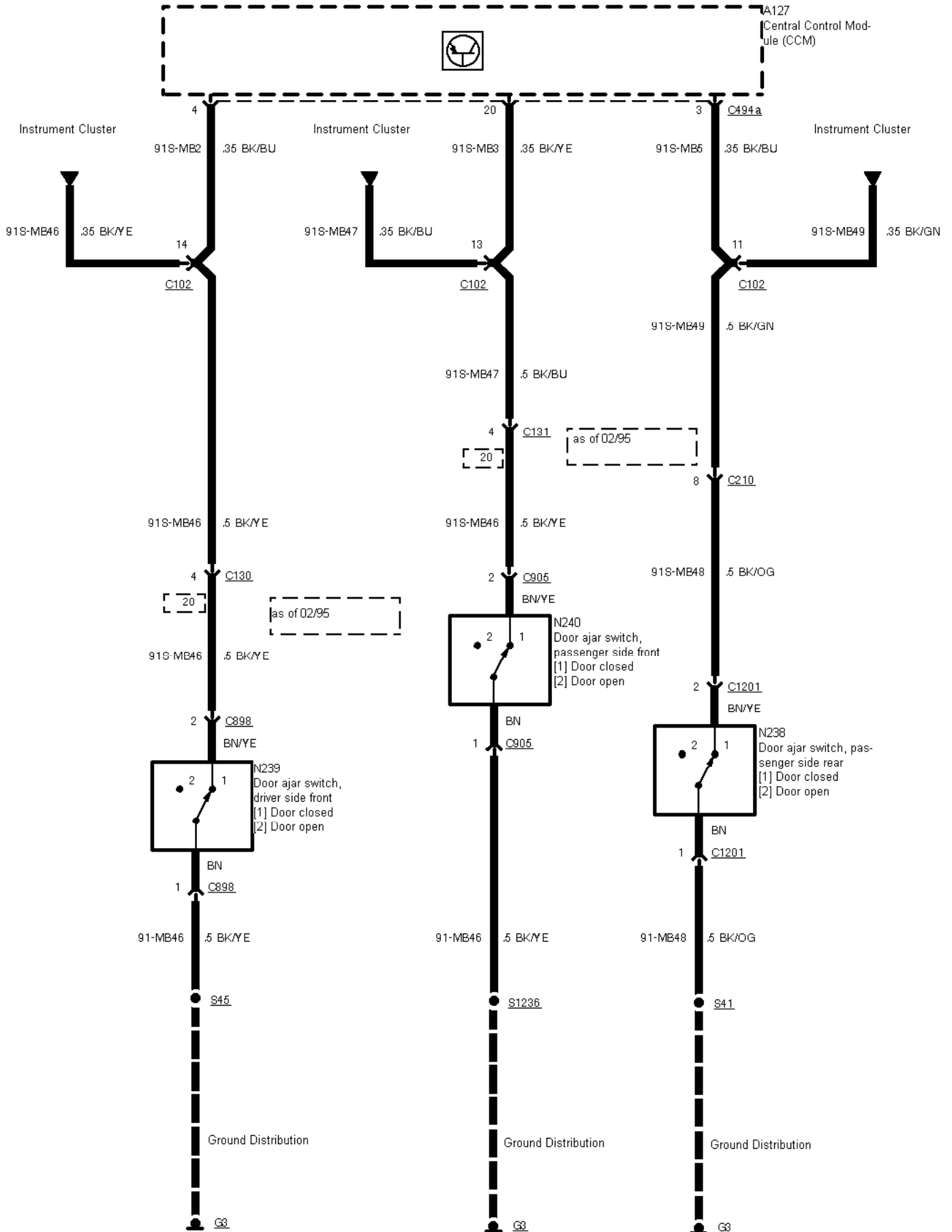

33-08-003 , Anti-theft Alarm

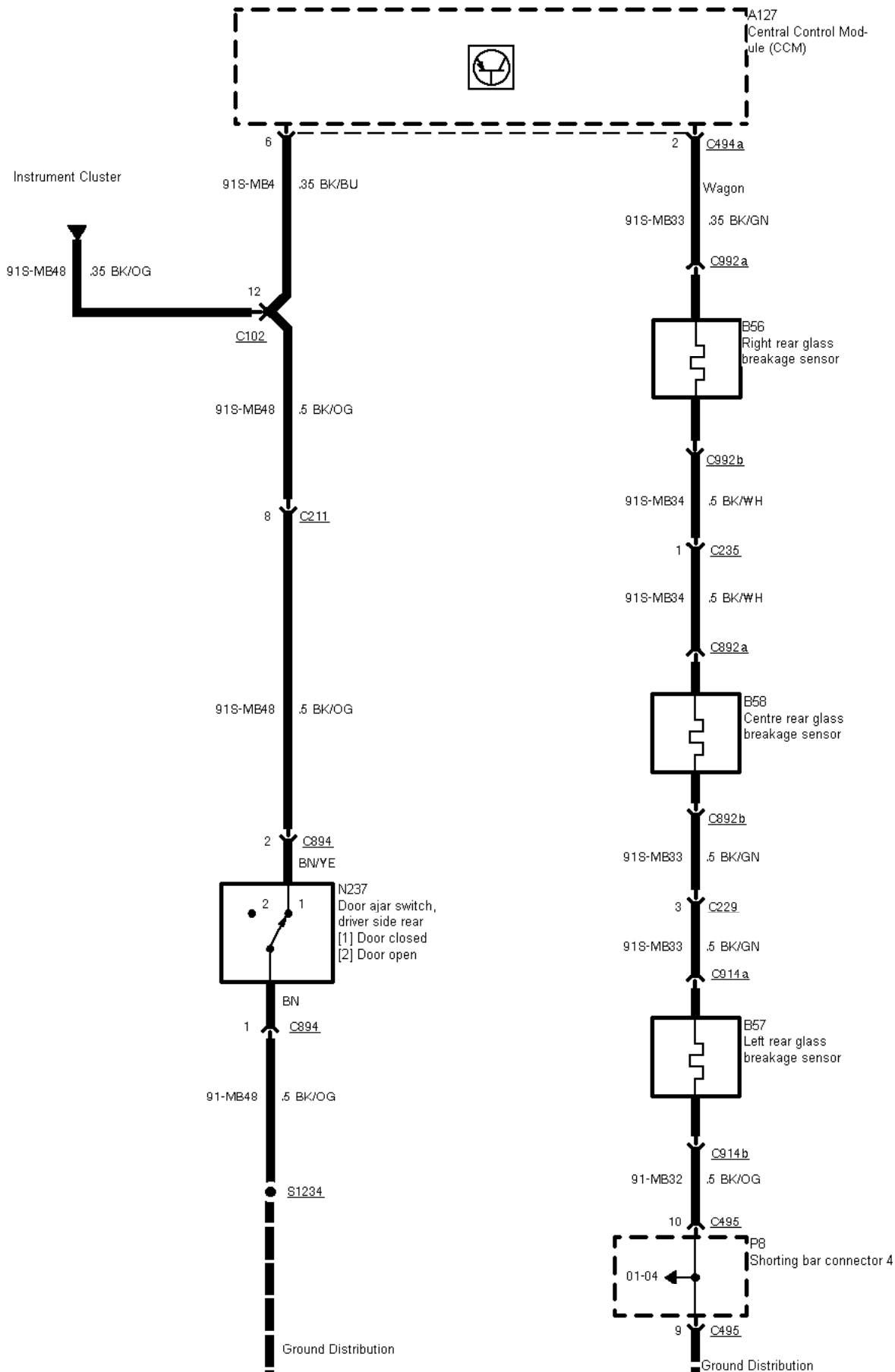



33-08-004 , Anti-theft Alarm

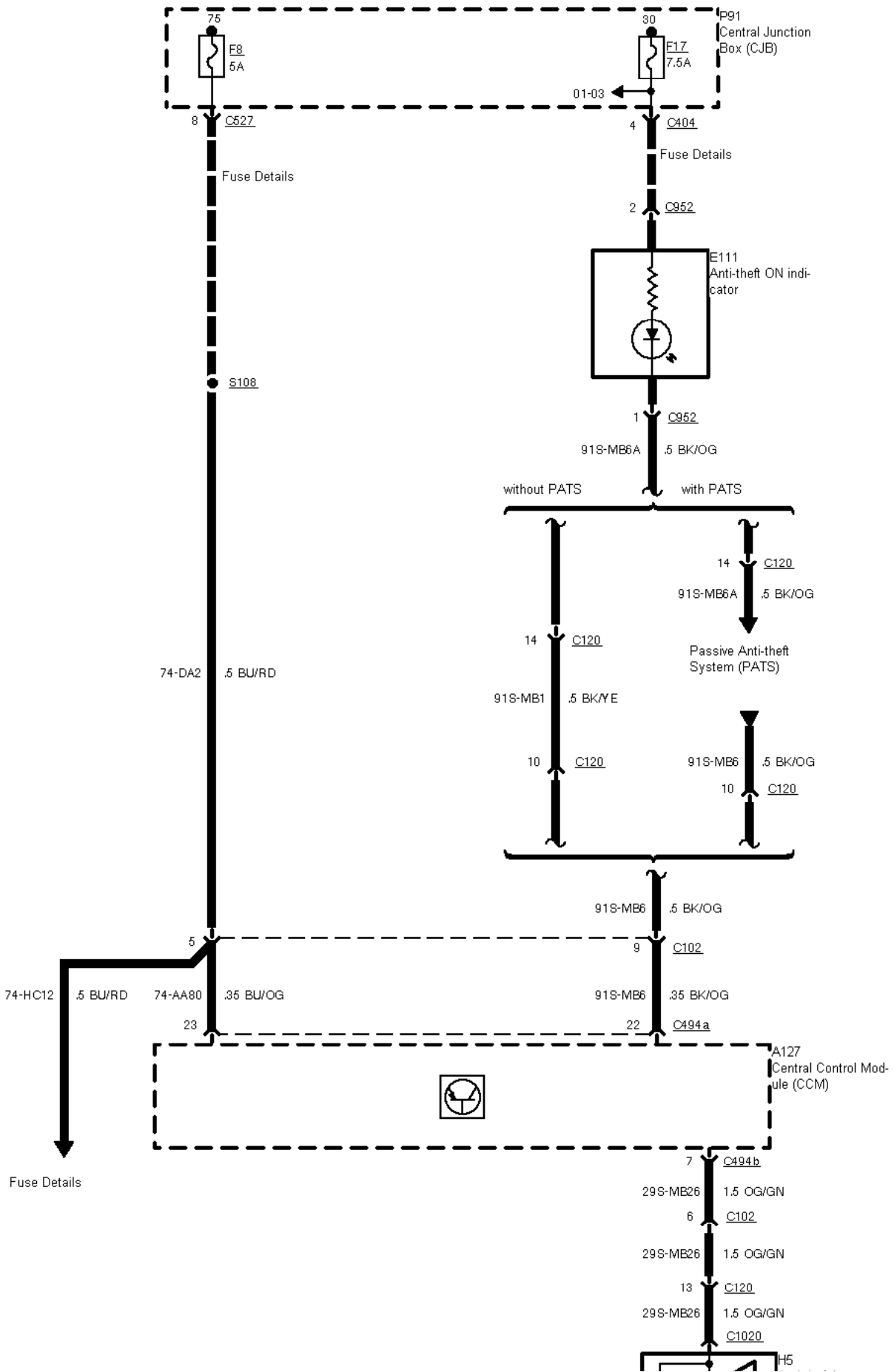

P91
Central Junction
Box (CJB)



8 C527

01-03

4 C404

Fuse Details

Fuse Details

2 C952

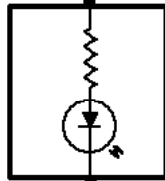

E111
Anti-theft ON indicator

1 C952

91S-MB6A .5 BK/OG

without PATS with PATS

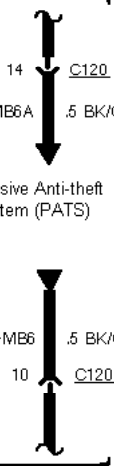

Passive Anti-theft
System (PATS)

74-DA2 .5 BU/RD

14 C120

14 C120

91S-MB6A .5 BK/OG

91S-MB1 .5 BK/YE

91S-MB6 .5 BK/OG

10 C120

10 C120

91S-MB6 .5 BK/OG

9 C102

91S-MB6 .35 BK/OG

22 C494a

74-HC12 .5 BU/RD

74-AA80 .35 BU/OG

23

A127
Central Control Mod-
ule (CCM)



7 C494b

29S-MB26 1.5 OG/GN

6 C102

29S-MB26 1.5 OG/GN

13 C120

29S-MB26 1.5 OG/GN

C1020

H5

Fuse Details

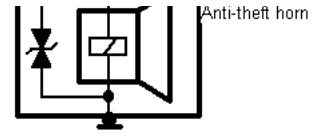

33-08-005 , Anti-theft Alarm

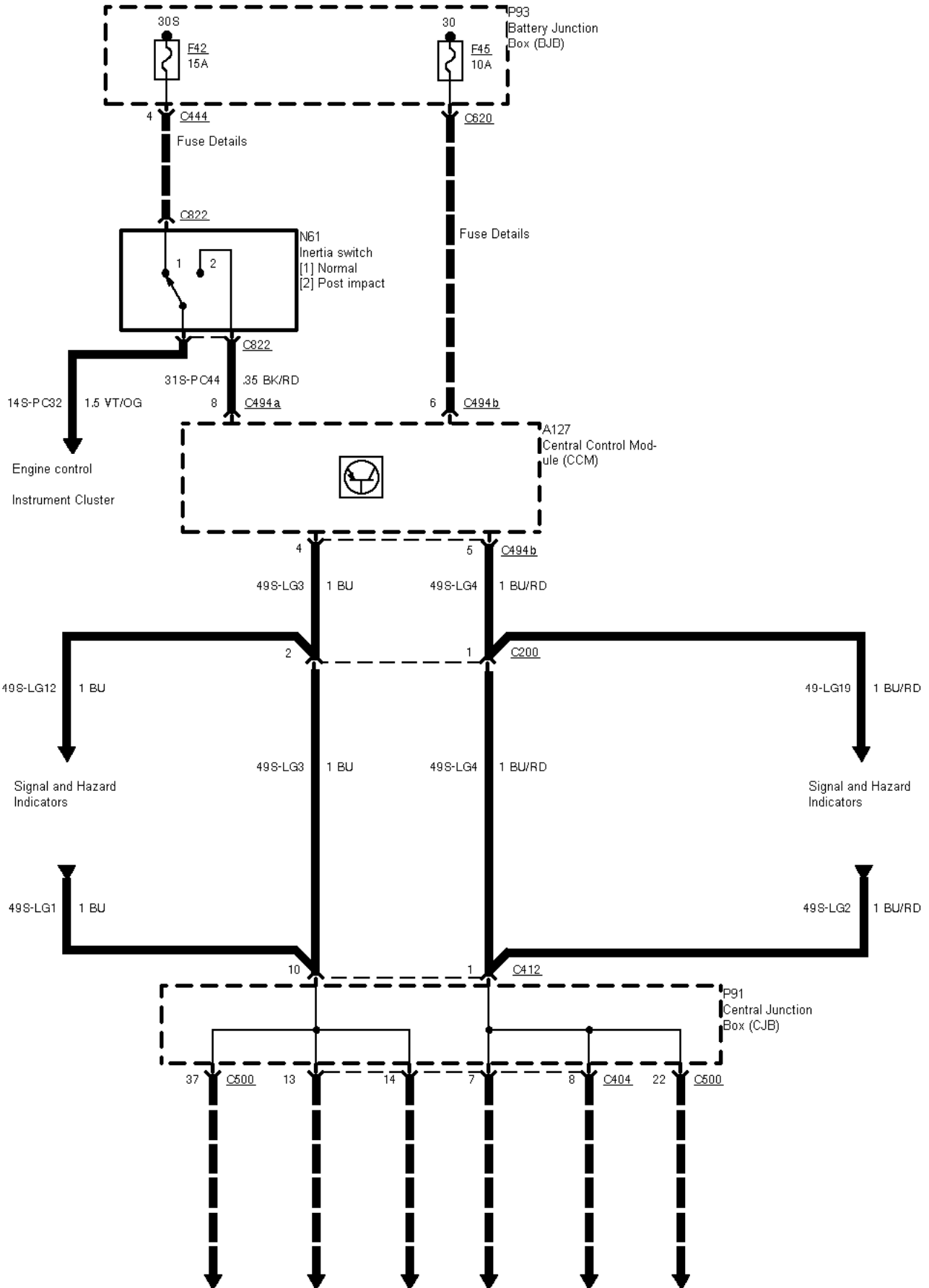



Signal and Hazard
Indicators

33-08-006 , Anti-theft Alarm

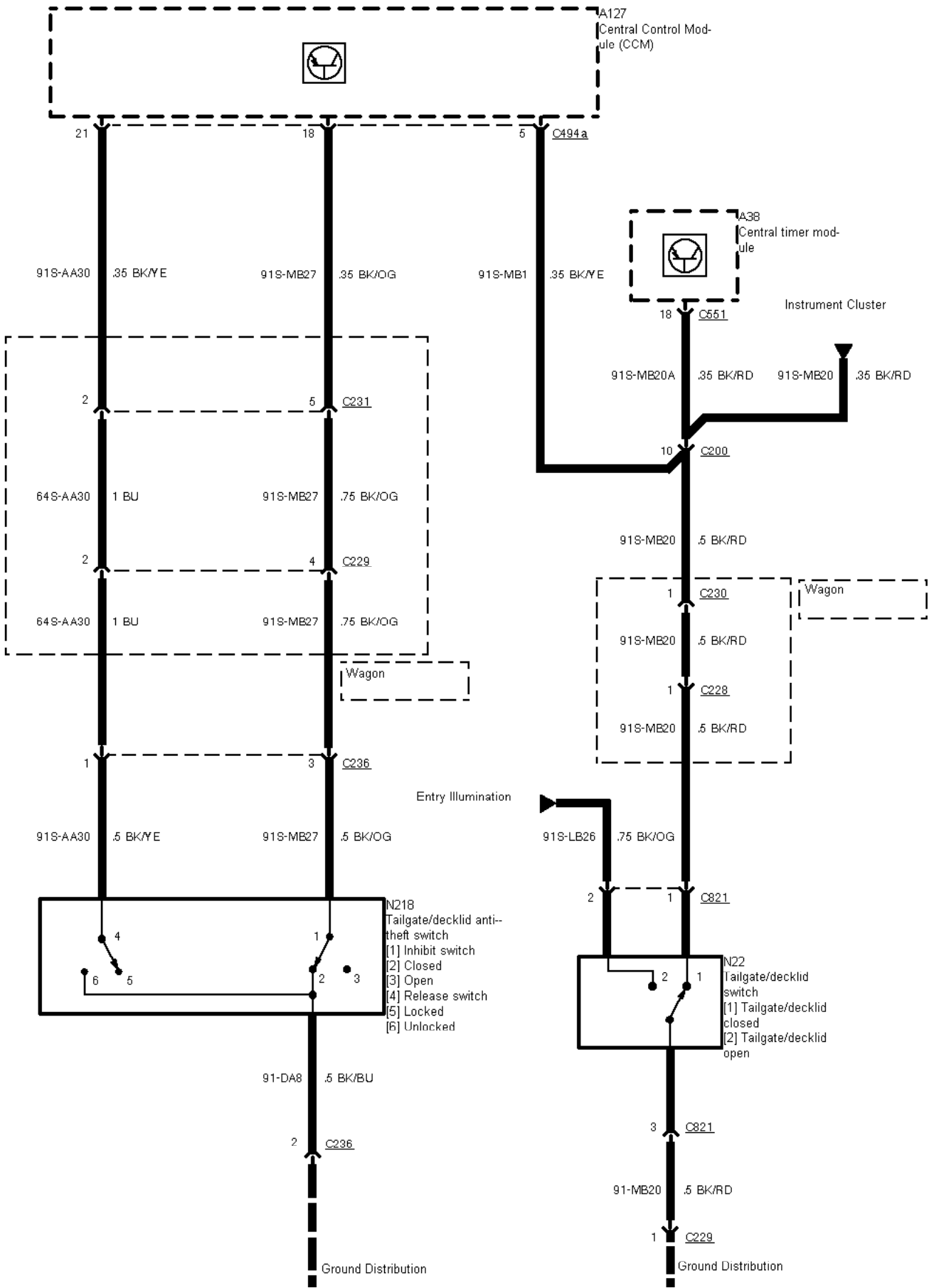

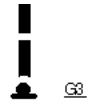

33-08-007 , Anti-theft Alarm , Door lock switches

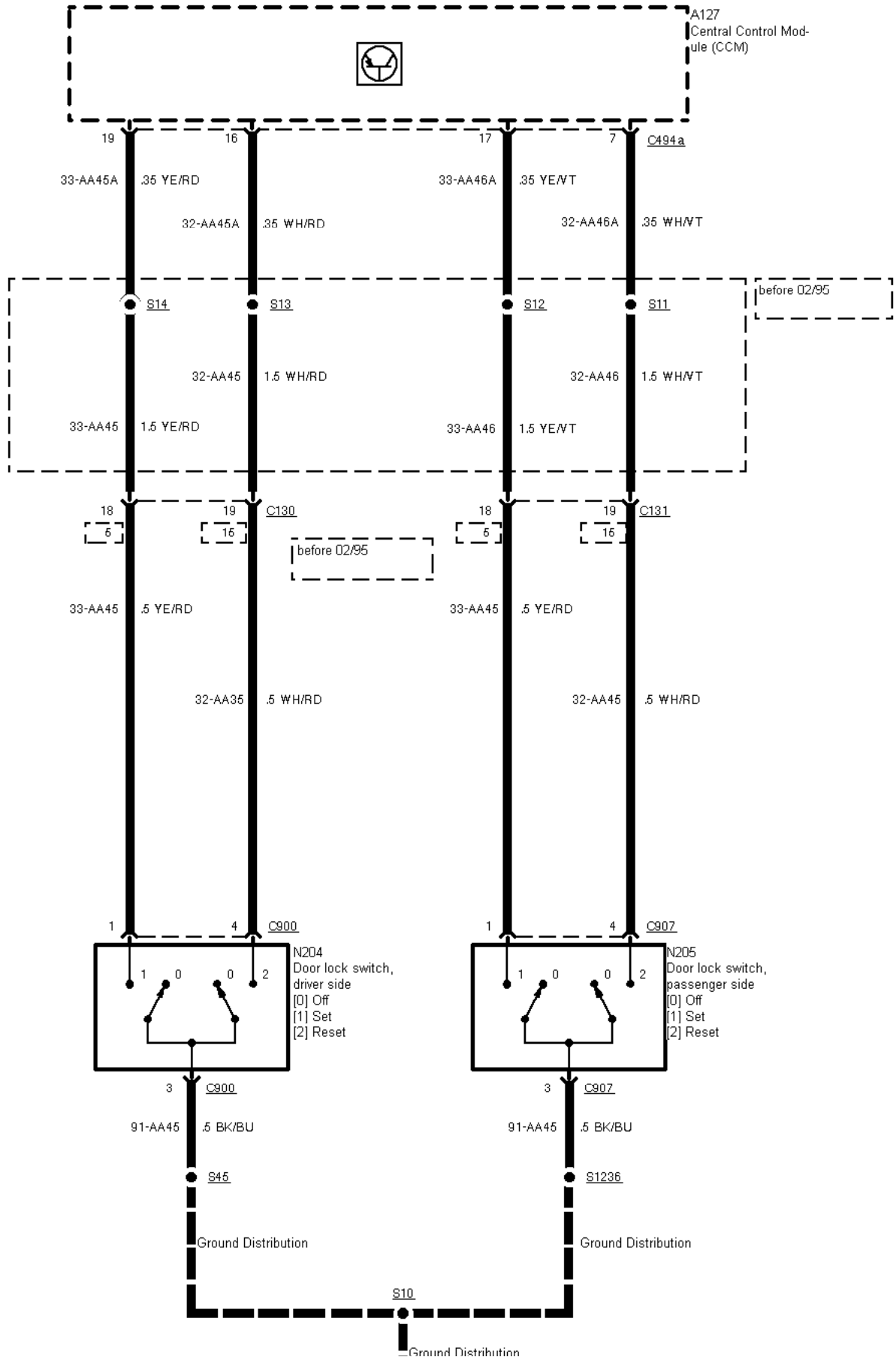

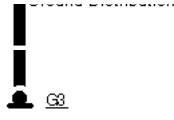

33-08-008 , Anti-theft Alarm



33-08-009 , Anti-theft Alarm , Anti-theft with interior scan sensor

RHD

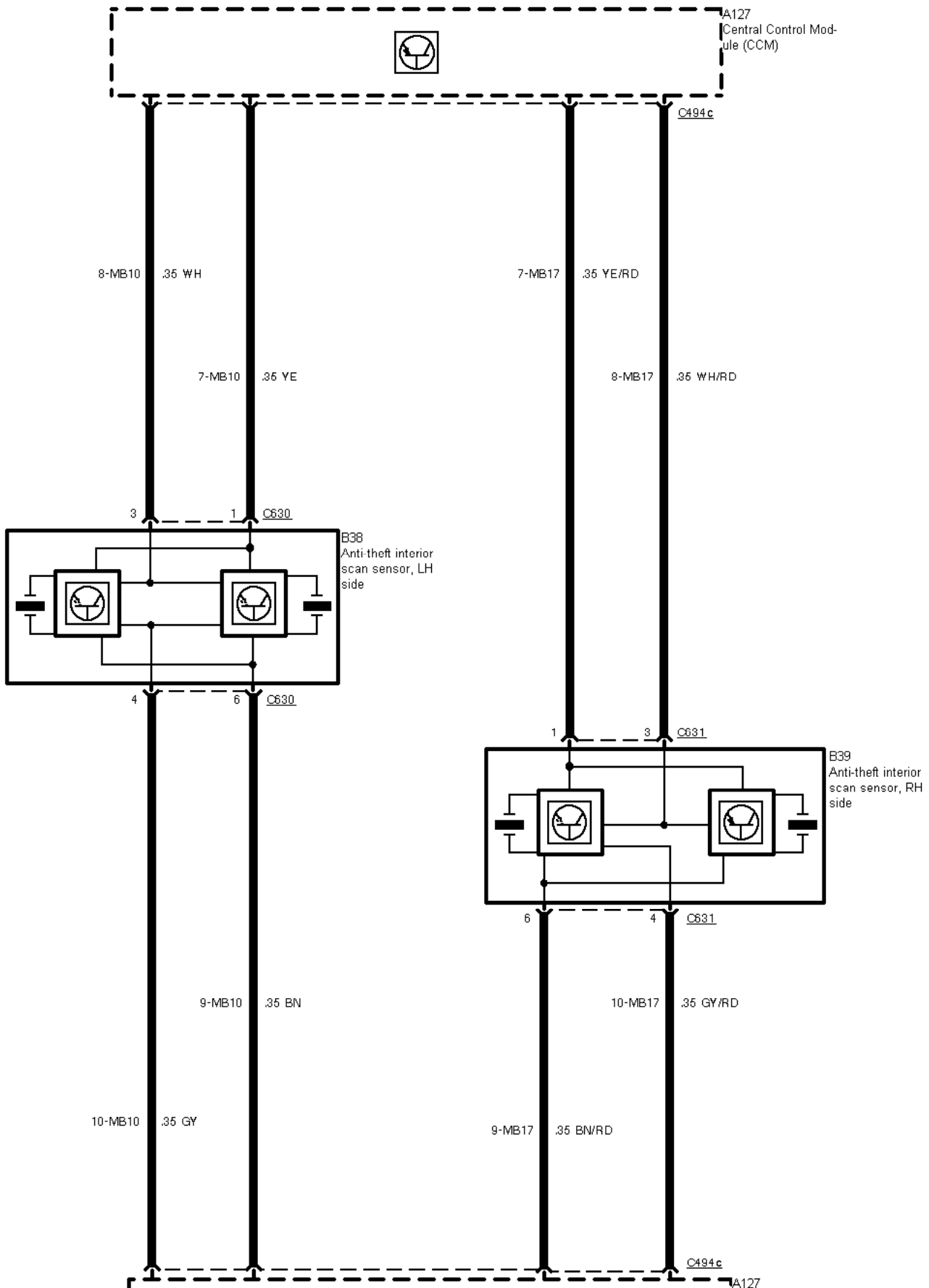

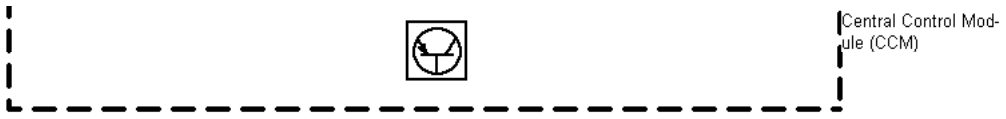

33-08-010 , Anti-theft Alarm , With remote control

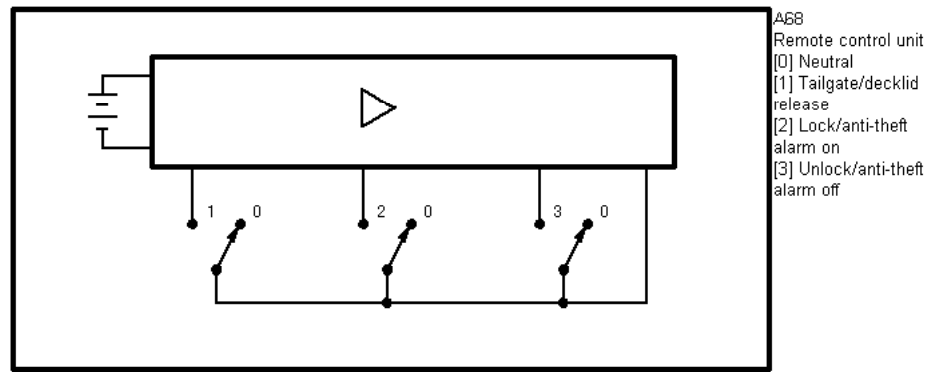
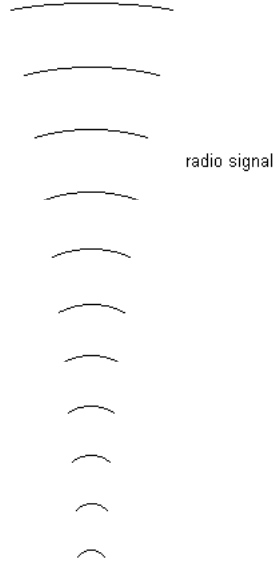
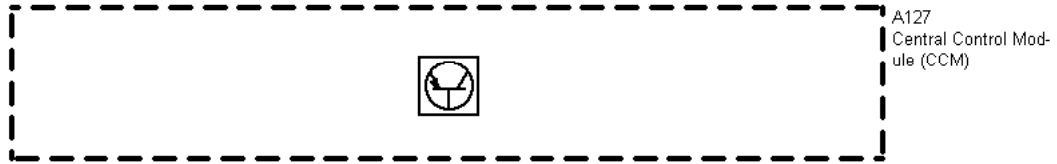

2 Circuit Description
