

34-03-001 , Air Conditioning (03/96 ->) , Without SATC module, petrol engines except 2,9 I V6 12V

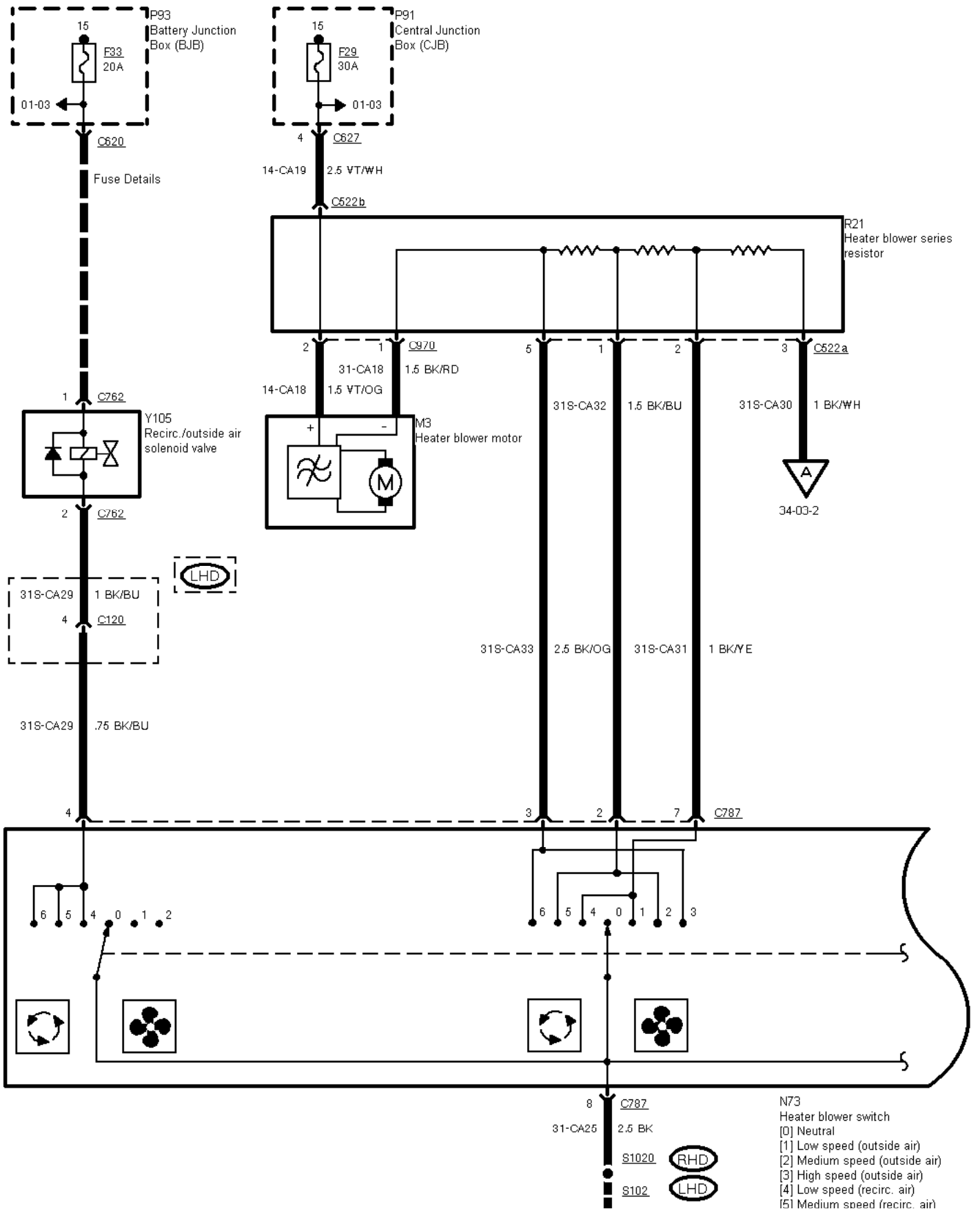

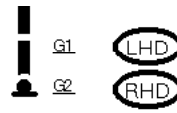
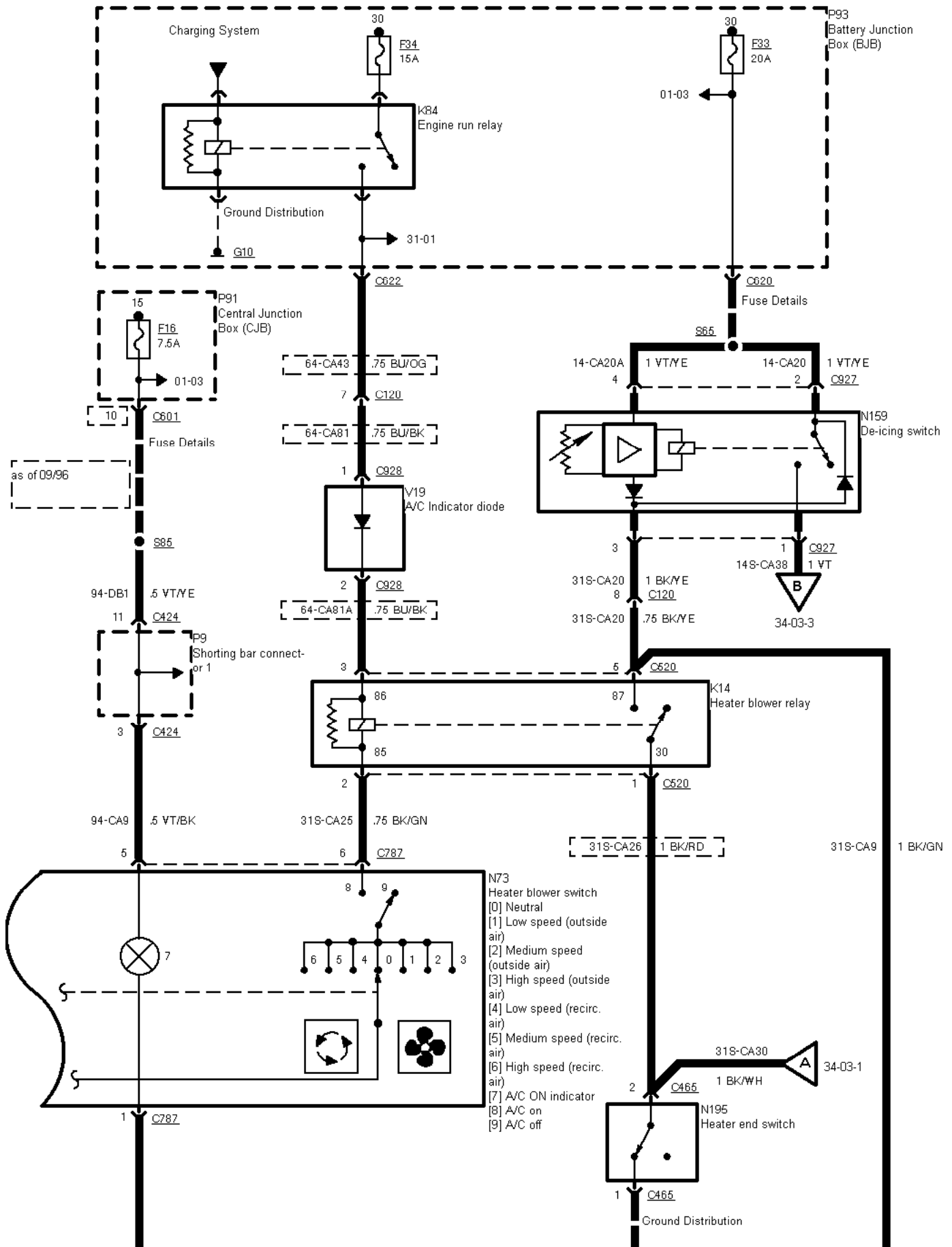

[6] High speed (recirc. air)

34-03-002 , Air Conditioning (03/96 ->) , Without SATC module, petrol engines except 2,9 I V6 12V



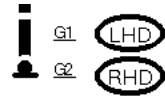

34-03-003 , Air Conditioning (03/96 ->) , Without SATC module, petrol engines except 2,9 I V6 12V

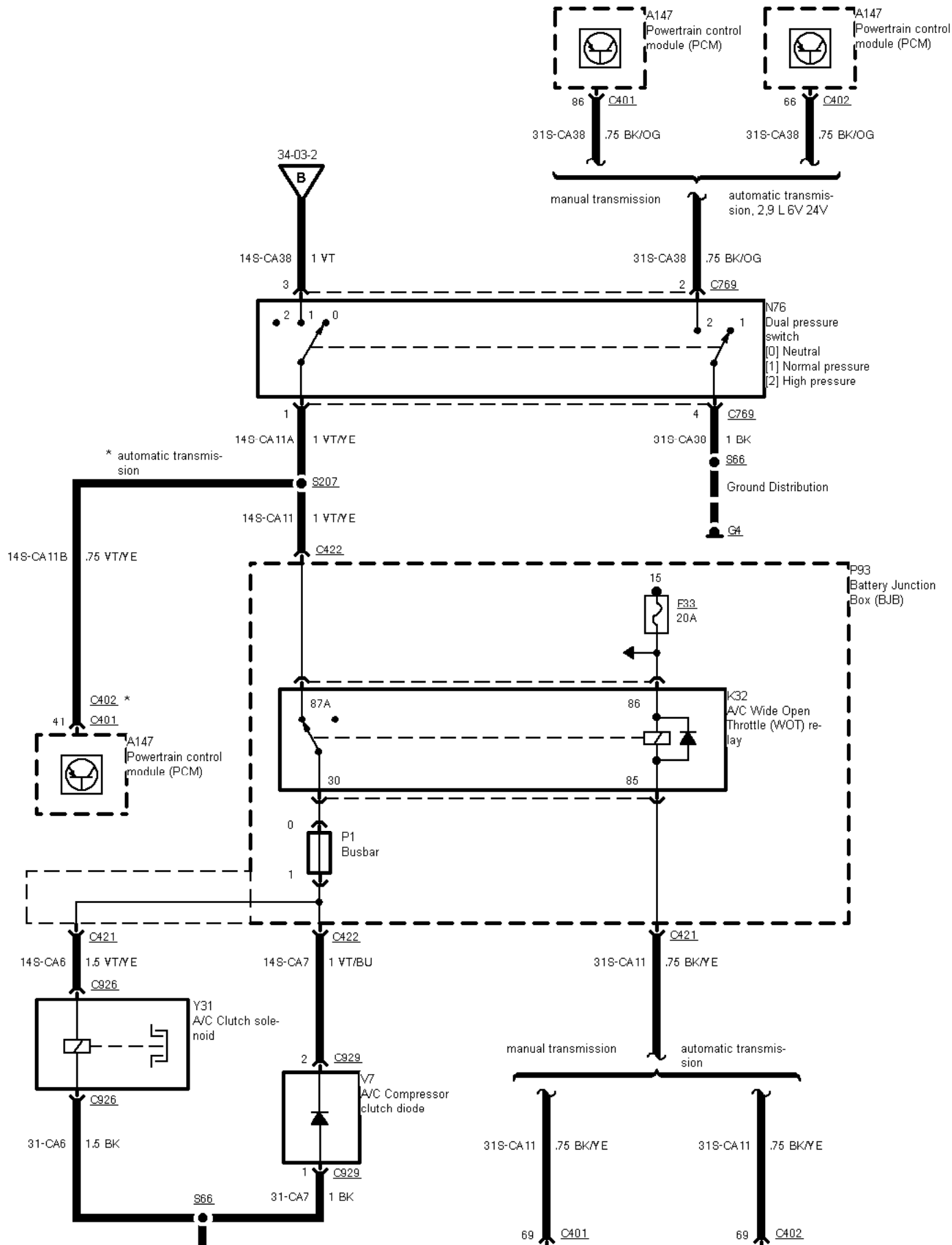

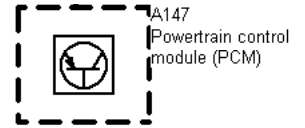
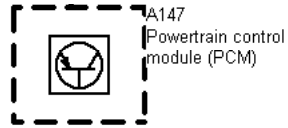
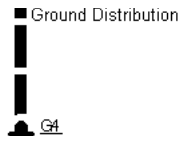

34-03-004 , Air Conditioning (03/96 ->) , Engine cooling fan, petrol engines except 2,9 I V6 12V

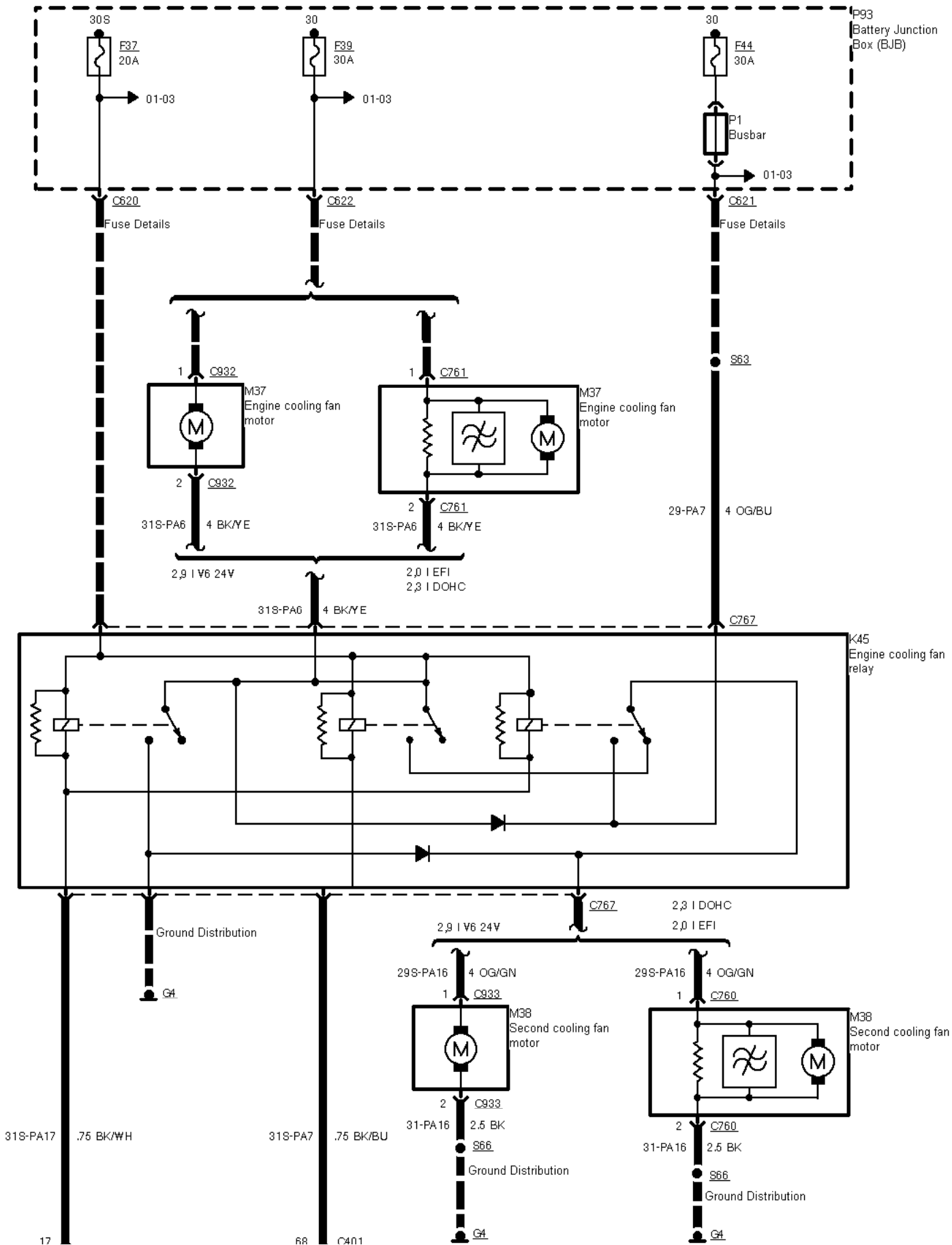

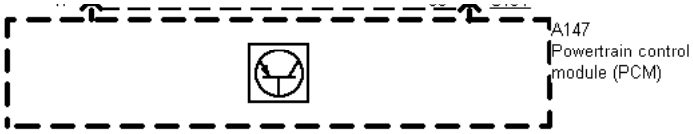

34-03-005 , Air Conditioning (03/96 ->) , Without SATC module, 2,9 I V6 12V, TCI Diesel from 03/96 to 09/96

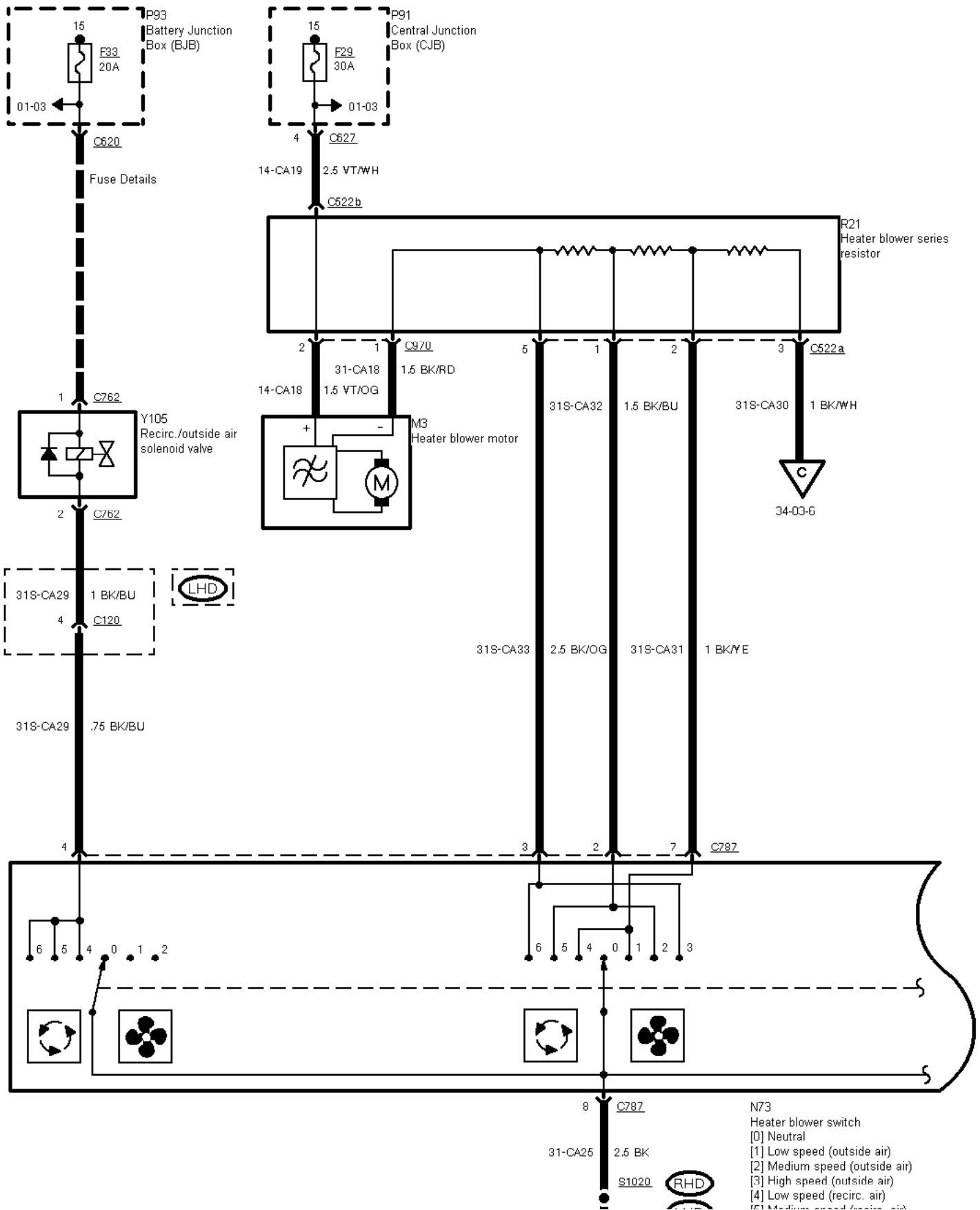

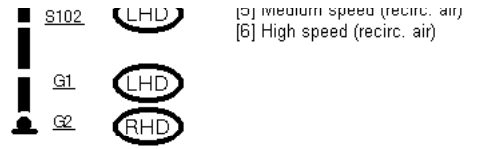

34-03-006 , Air Conditioning (03/96 ->) , Without SATC module, 2,9 I V6 12V, TCI Diesel from 03/96 to 09/96

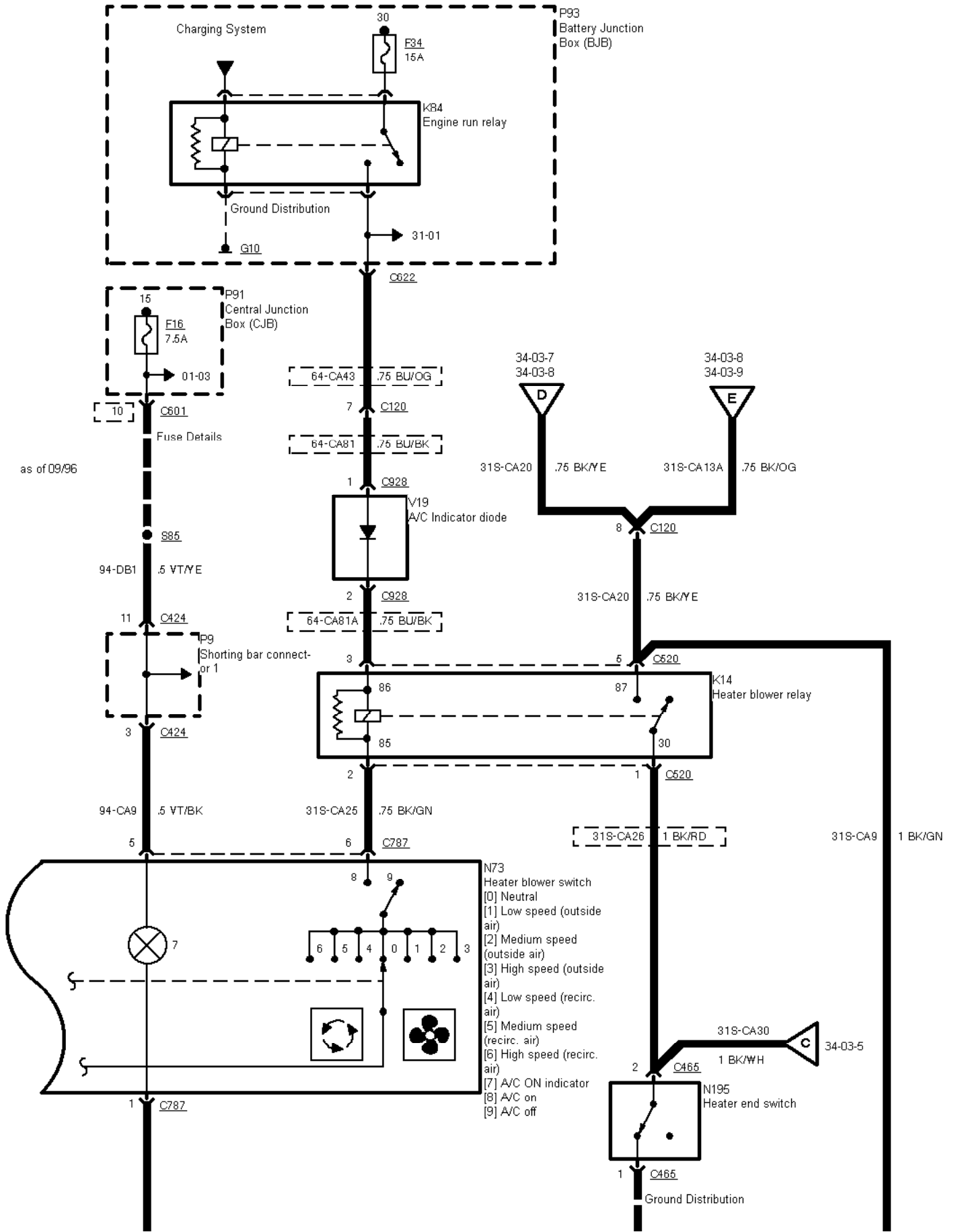

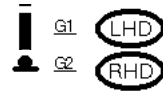

34-03-007 , Air Conditioning (03/96 ->) , Without SATC module, 2,9 l V6 12V as of 03/96

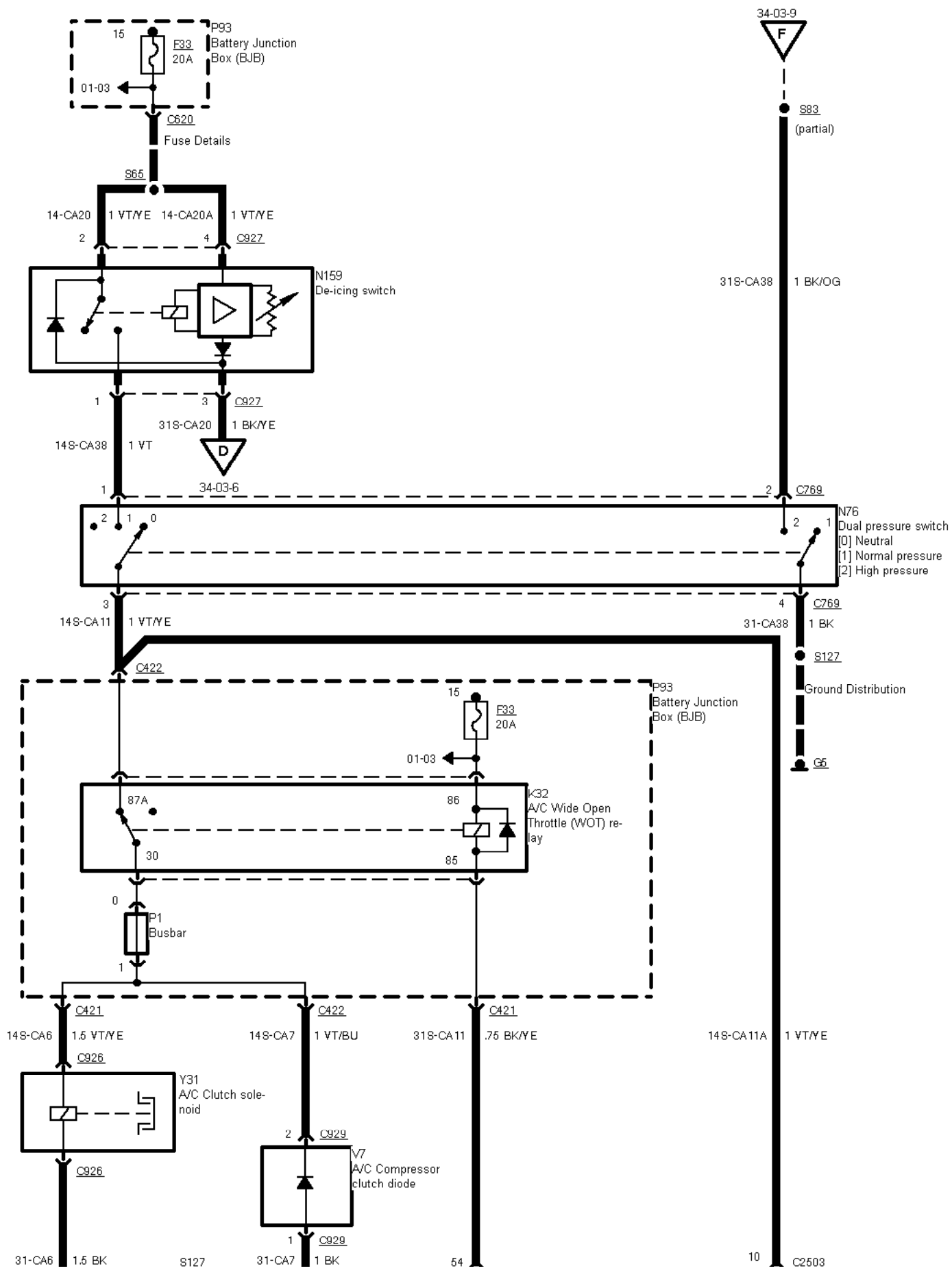

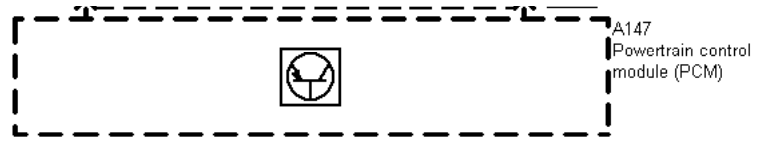
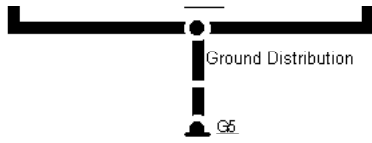

34-03-008 , Air Conditioning (03/96 ->) , Without SATC module, TCI Diesel from 03/94 to 09/96

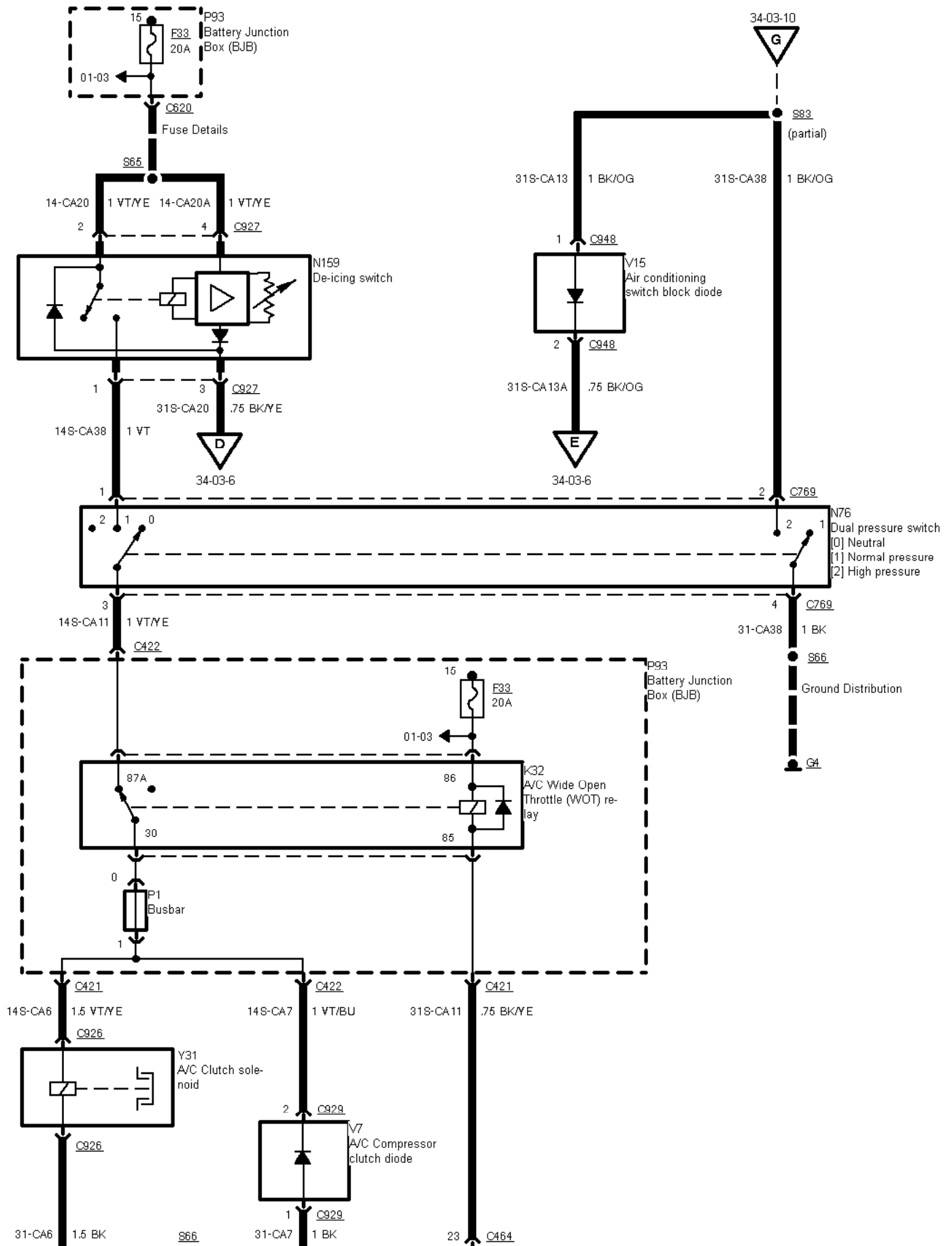

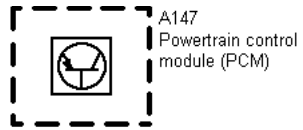
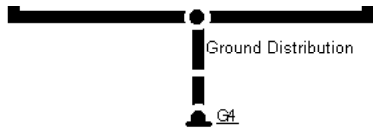

34-03-009 , Air Conditioning (03/96 ->) , Engine cooling fan, 2,9 I V6 12V

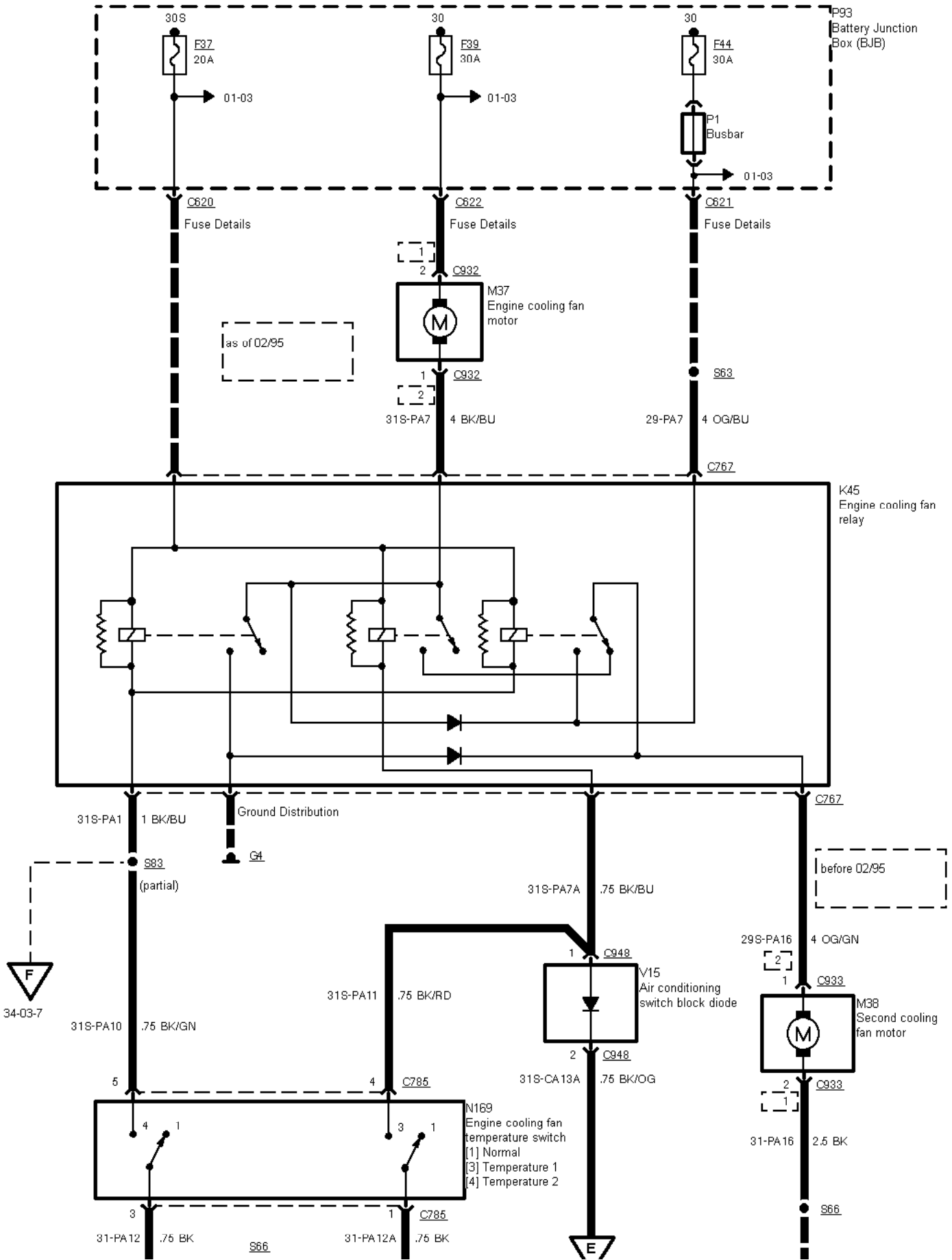

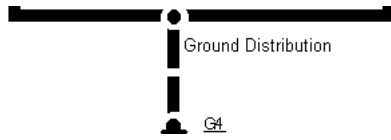

V
34-03-6

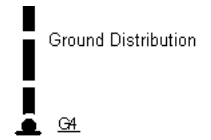

34-03-010 , Air Conditioning (03/96 ->) , Engine cooling fan, TCI Diesel

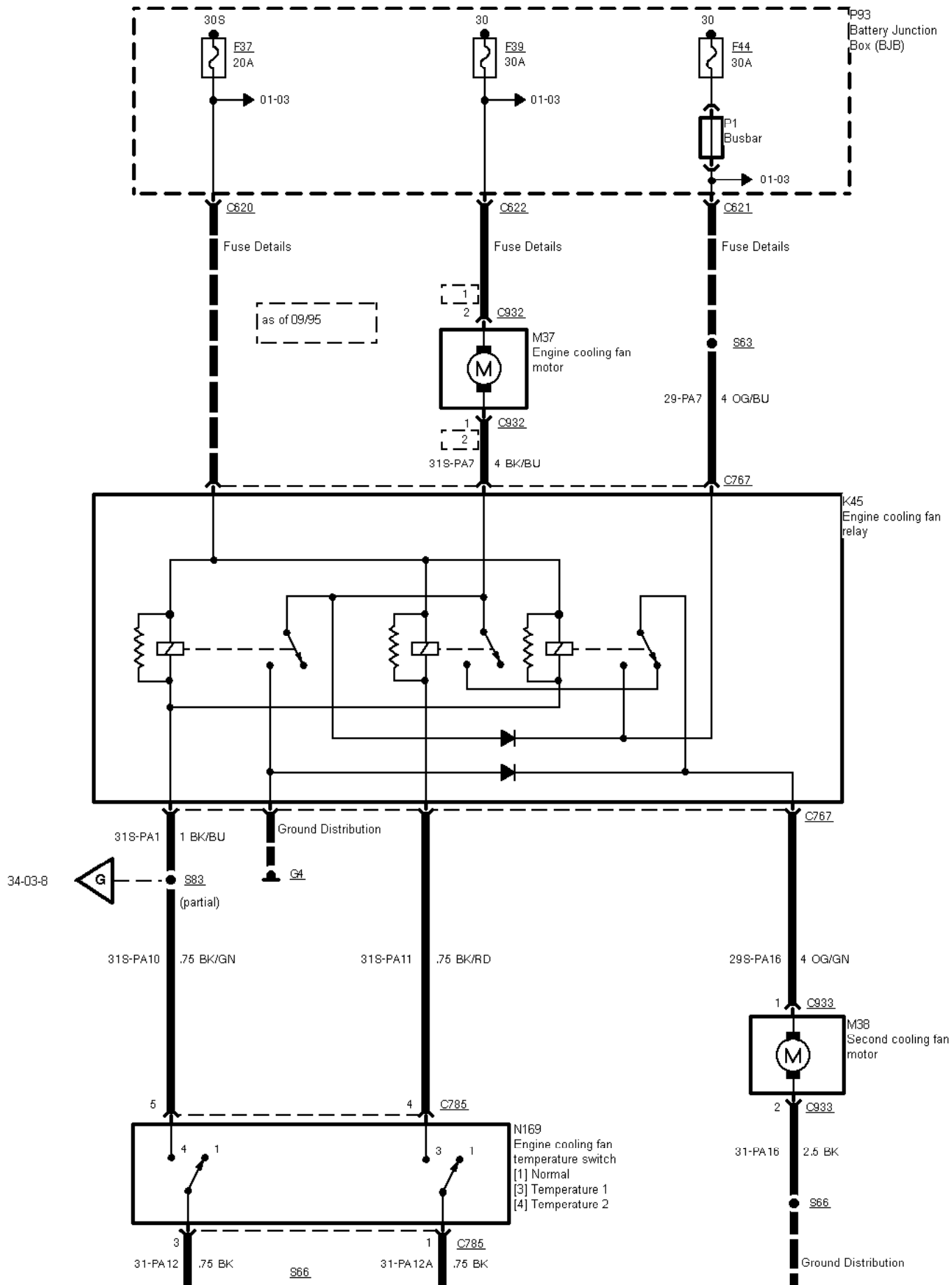

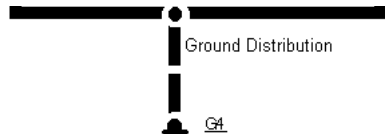

34-03-011 , Air Conditioning (03/96 ->) , Without SATC module, TCI Diesel as of 09/96

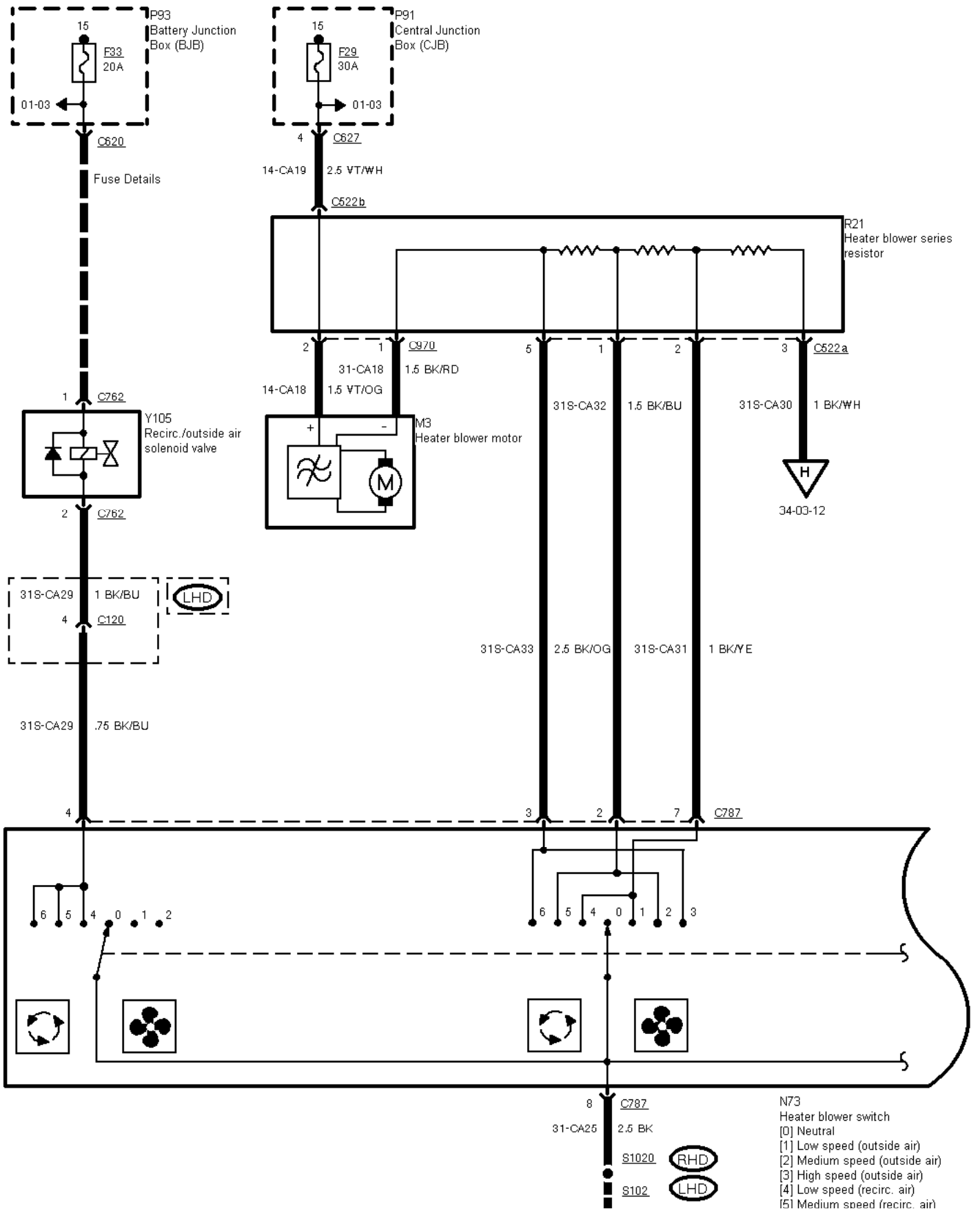

- N73
Heater blower switch
[0] Neutral
[1] Low speed (outside air)
[2] Medium speed (outside air)
[3] High speed (outside air)
[4] Low speed (recirc. air)
[5] Medium speed (recirc. air)

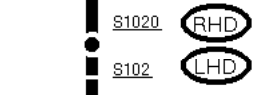

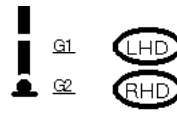

[6] High speed (recirc. air)

34-03-012 , Air Conditioning (03/96 ->) , Without SATC module, TCI Diesel as of 09/96

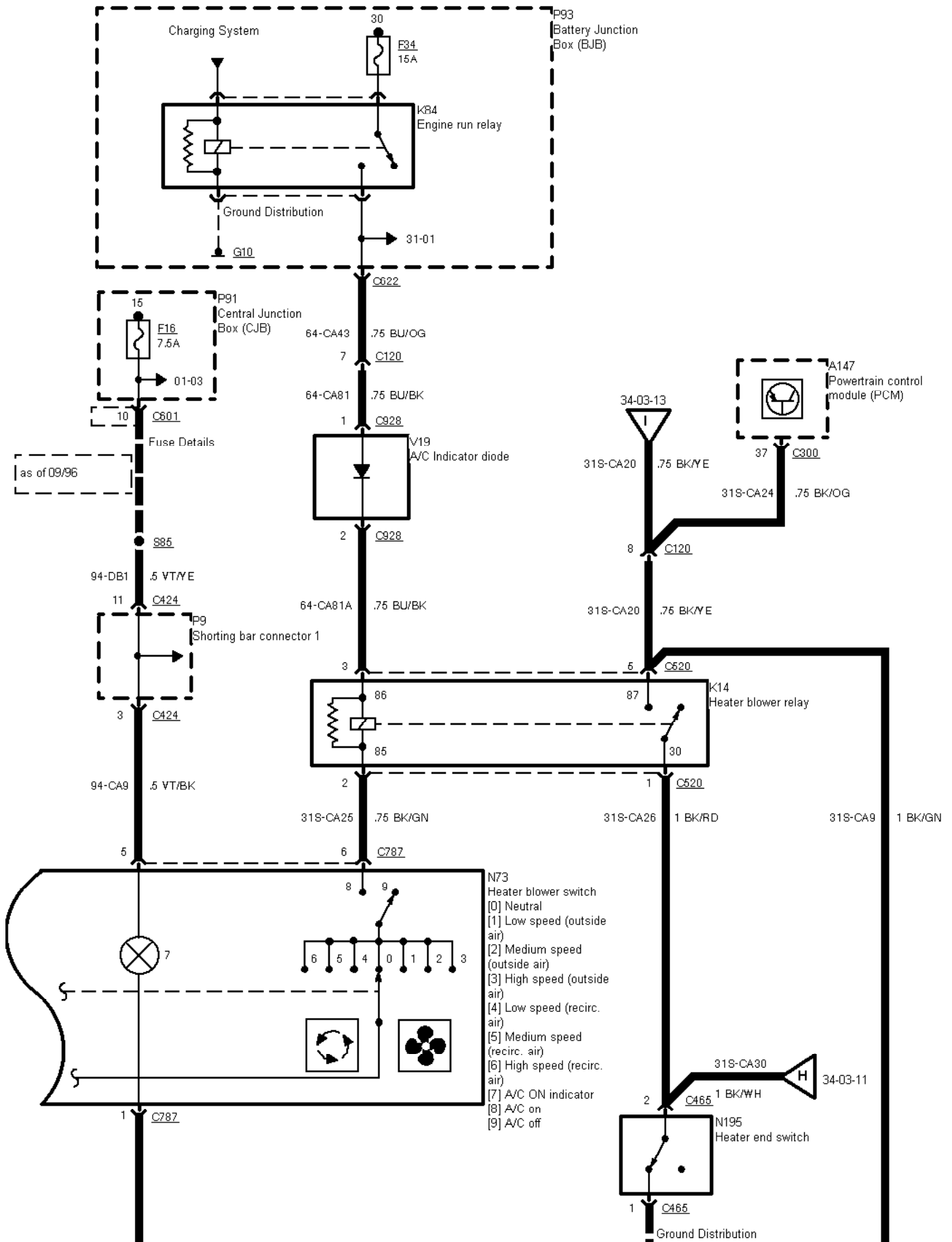



* 2,9 l V6 12V

34-03-013 , Air Conditioning (03/96 ->) , Without SATC module, TCI Diesel as of 09/96

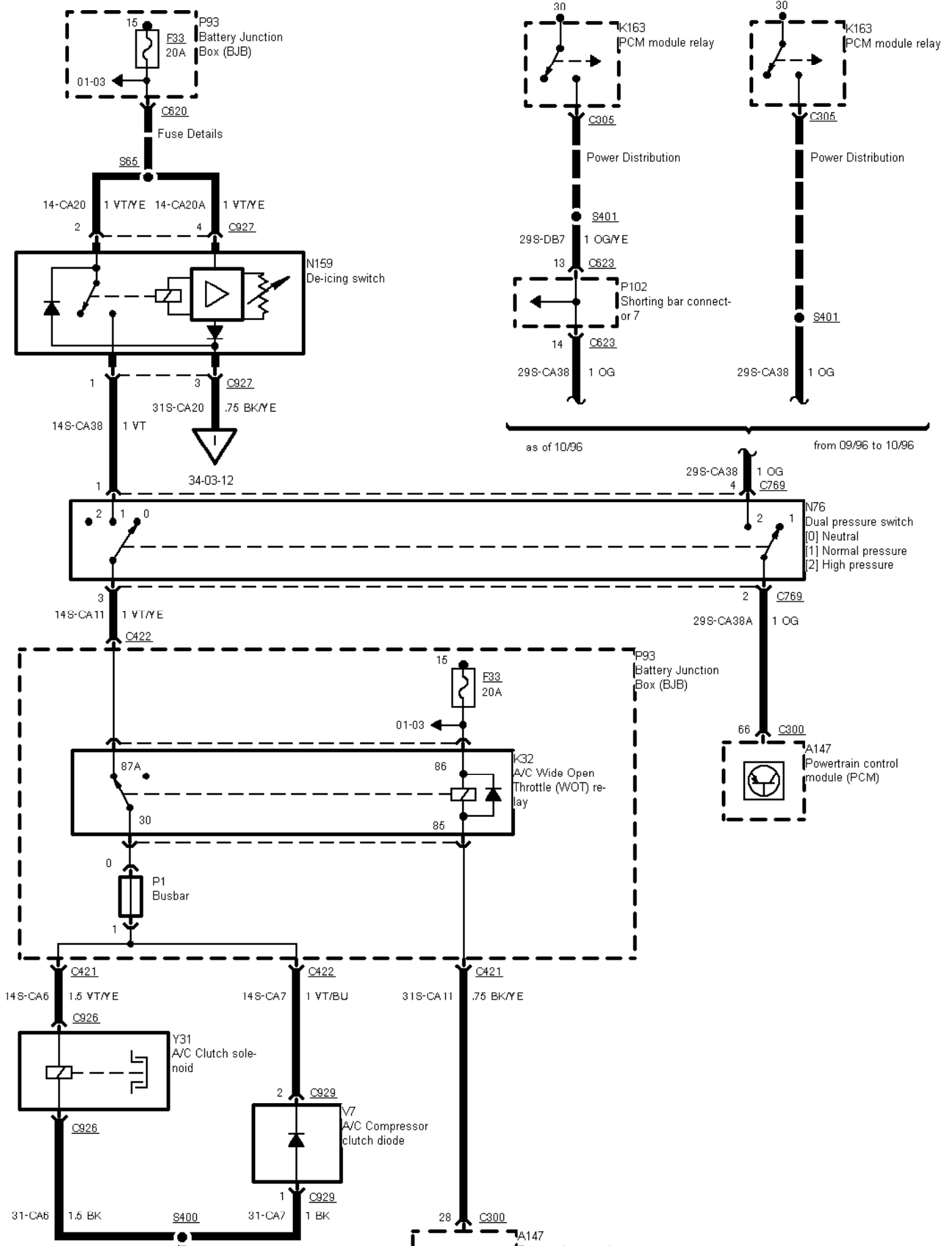

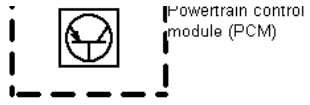
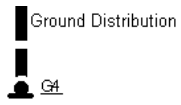

34-03-014 , Air Conditioning (03/96 ->) , Engine cooling fan, TCI Diesel as of 09/96

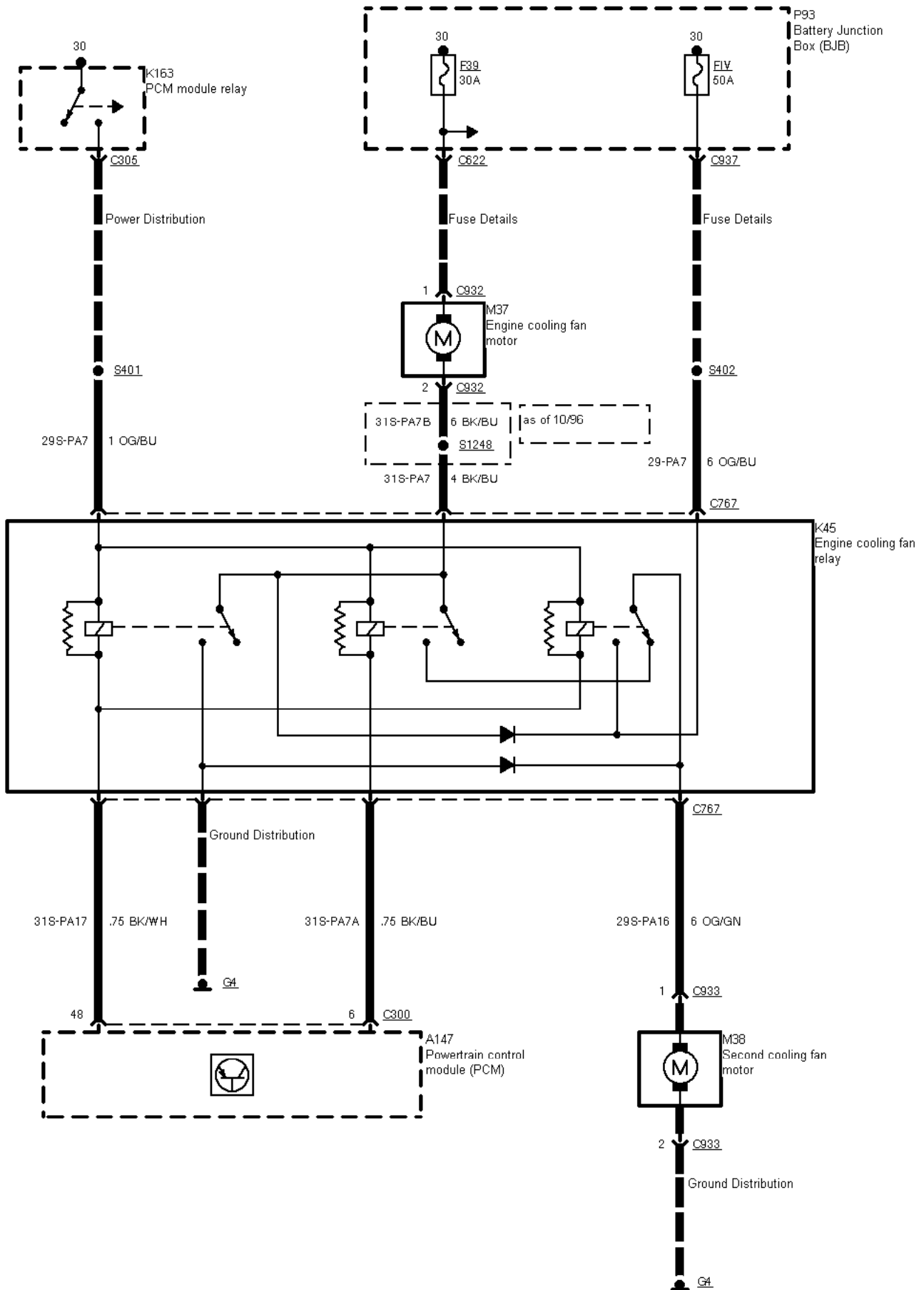

2 Circuit Description
