

34-02-001 , Air Conditioning , Without SATC module, except 2,9 I V6 12V, except TCI Diesel

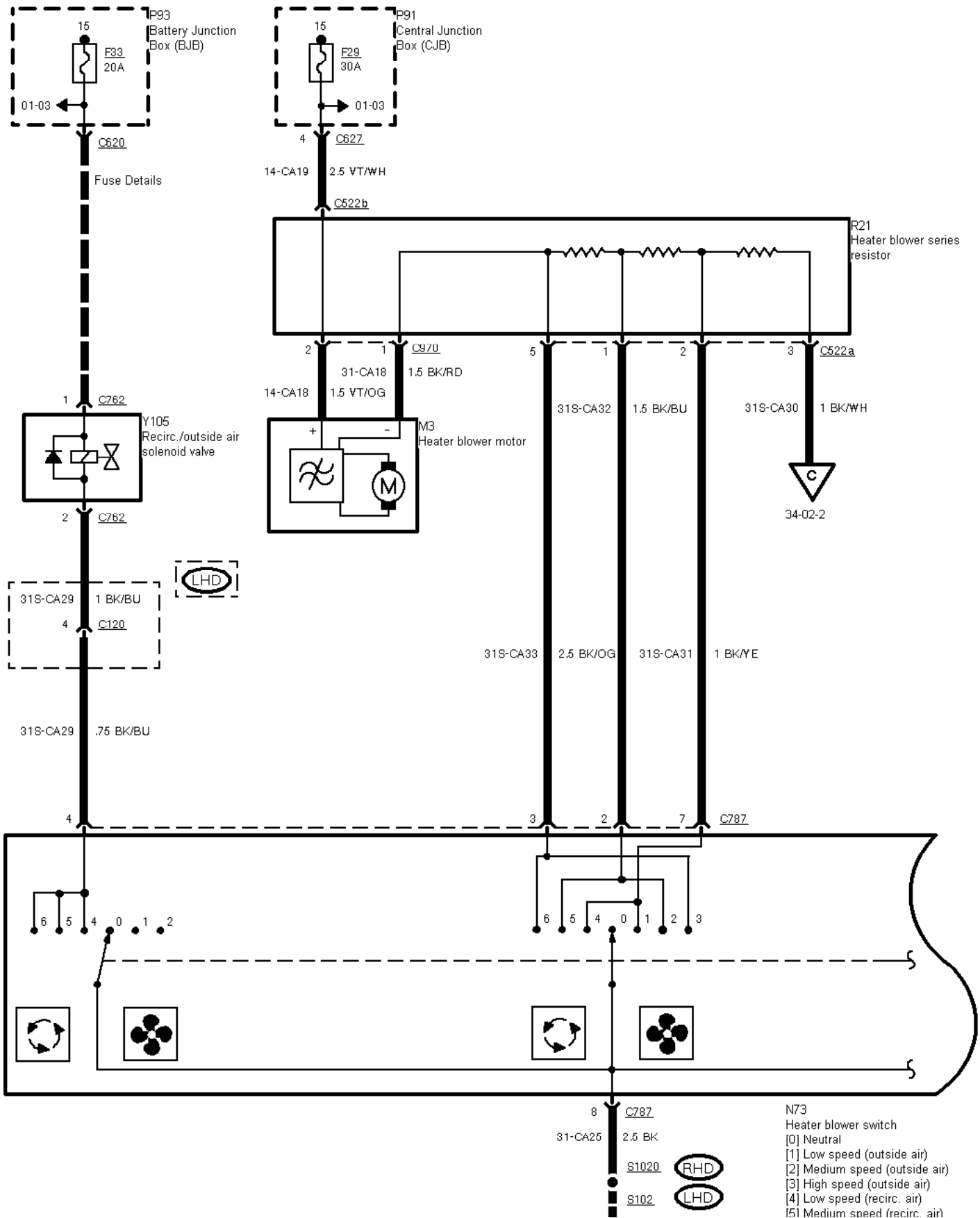

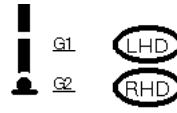
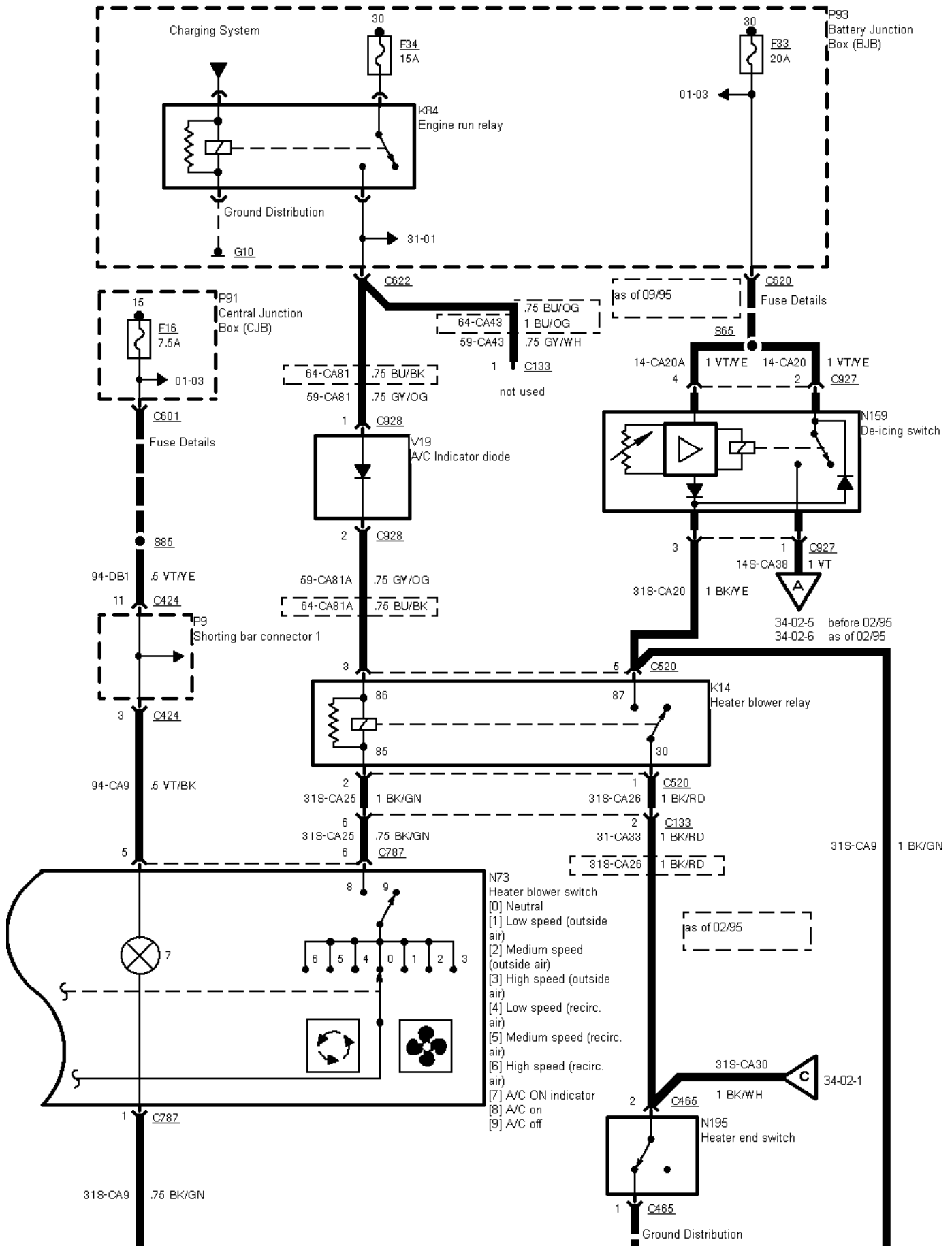

[6] High speed (recirc. air)

34-02-002 , Air Conditioning , Without SATC module, except 2,9 I V6 12V, except TCI Diesel





34-02-003 , Air Conditioning , Without SATC module, 2,9 I V6 12V, TCI Diesel

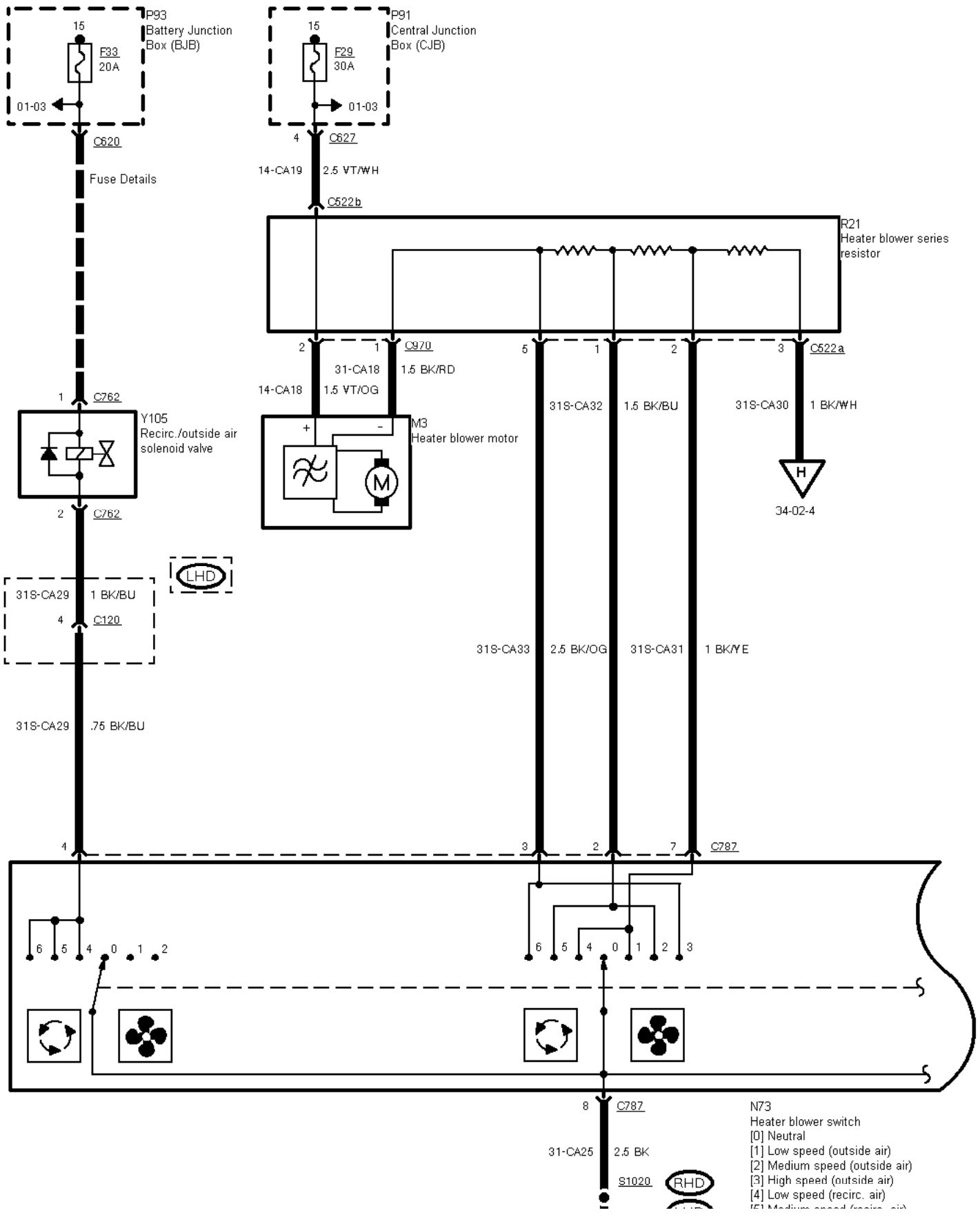



[5] medium speed (recirc. air)
[6] High speed (recirc. air)

34-02-004 , Air Conditioning , Without SATC module, 2,9 I V6 12V, TCI Diesel

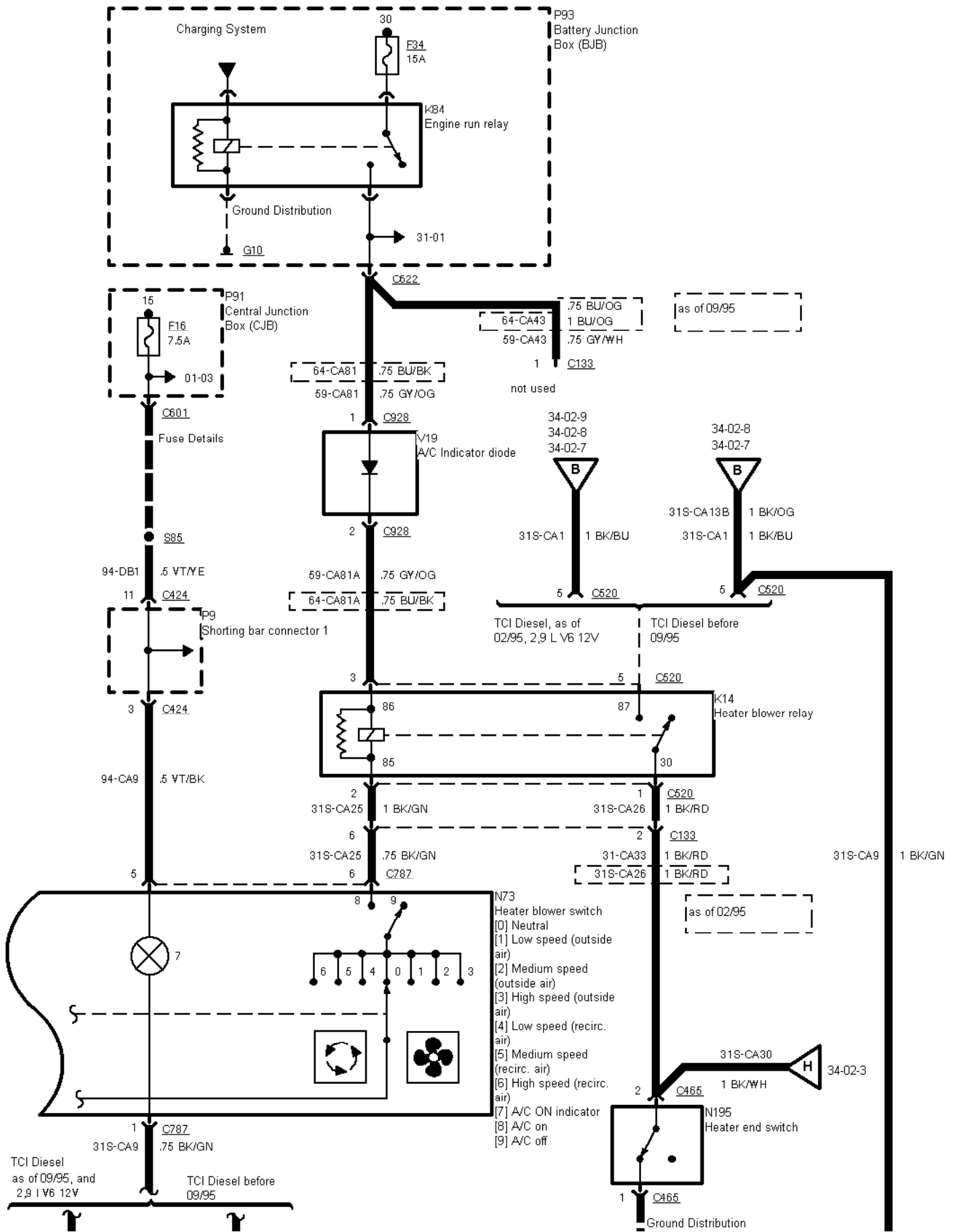

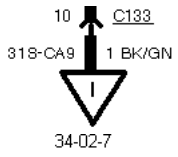

34-02-005 , Air Conditioning , Without SATC module , Petrol engines before 02/95, except 2,9 I V6 12V

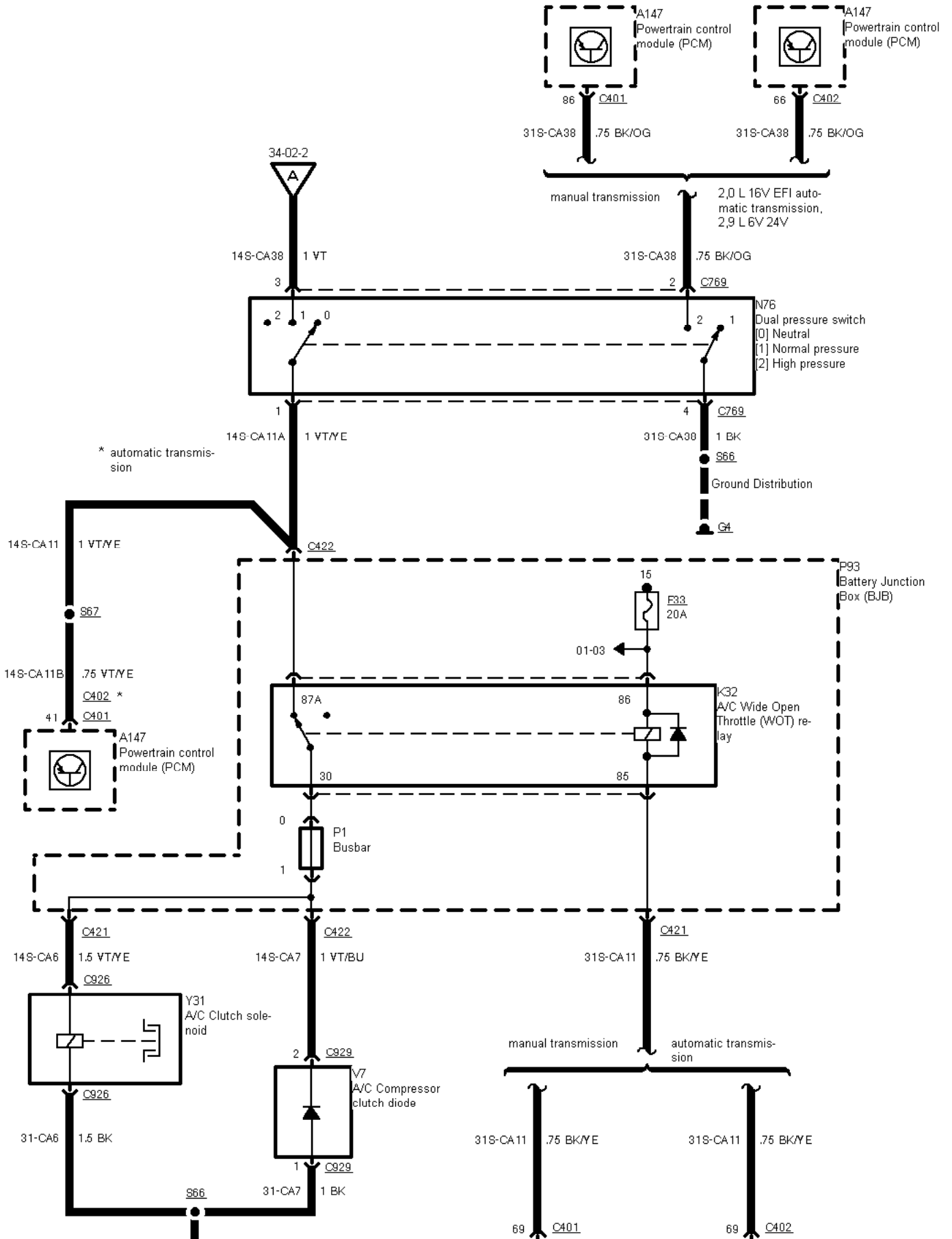

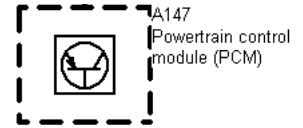
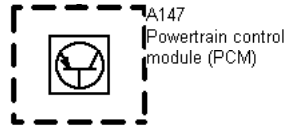
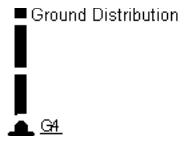

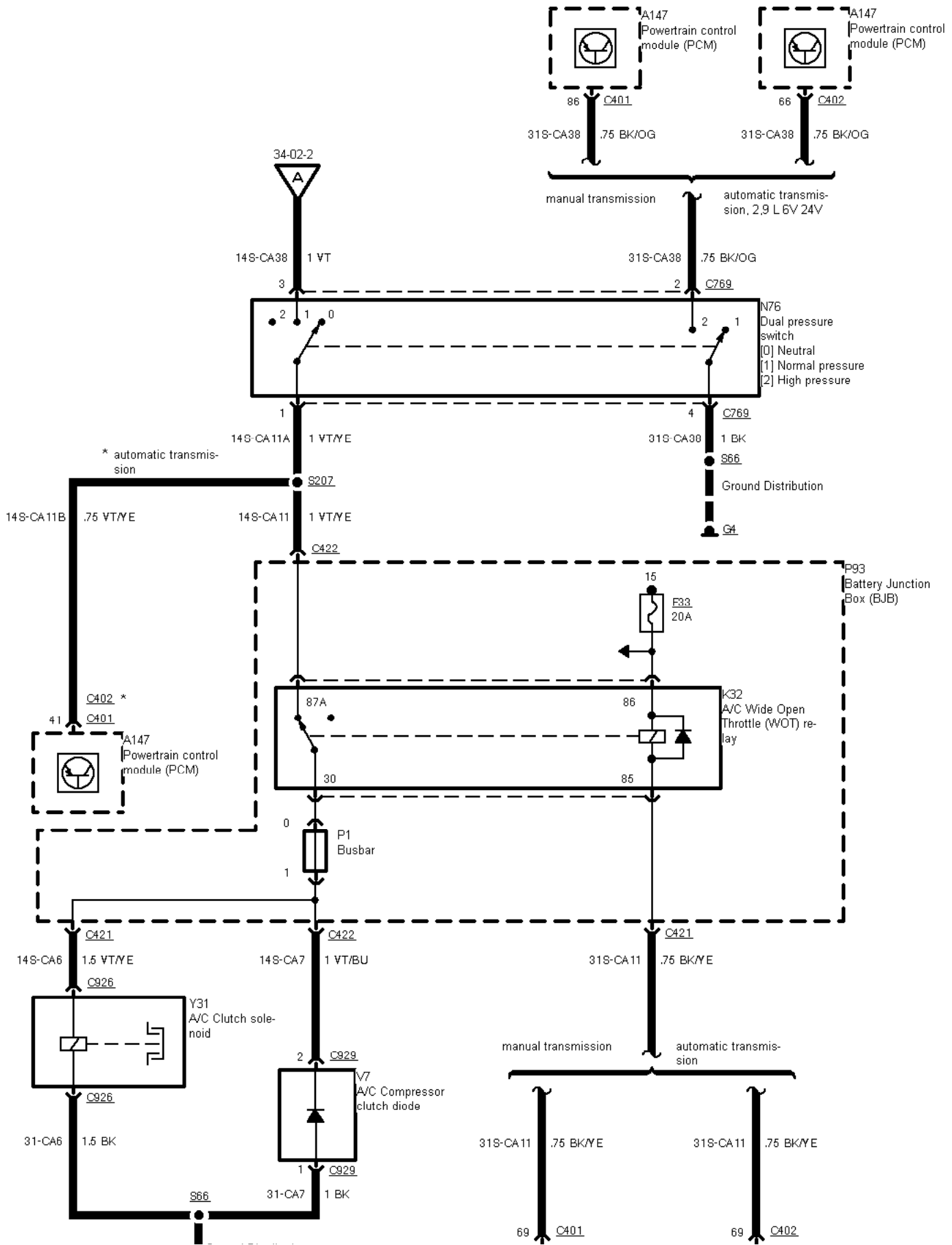

34-02-006 , Air Conditioning , Without SATC module, Petrol engines as of 02/95, except 2,9 I V6 12V

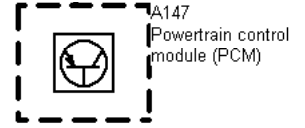
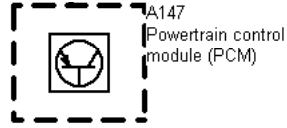
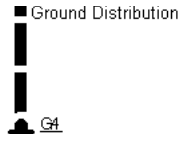

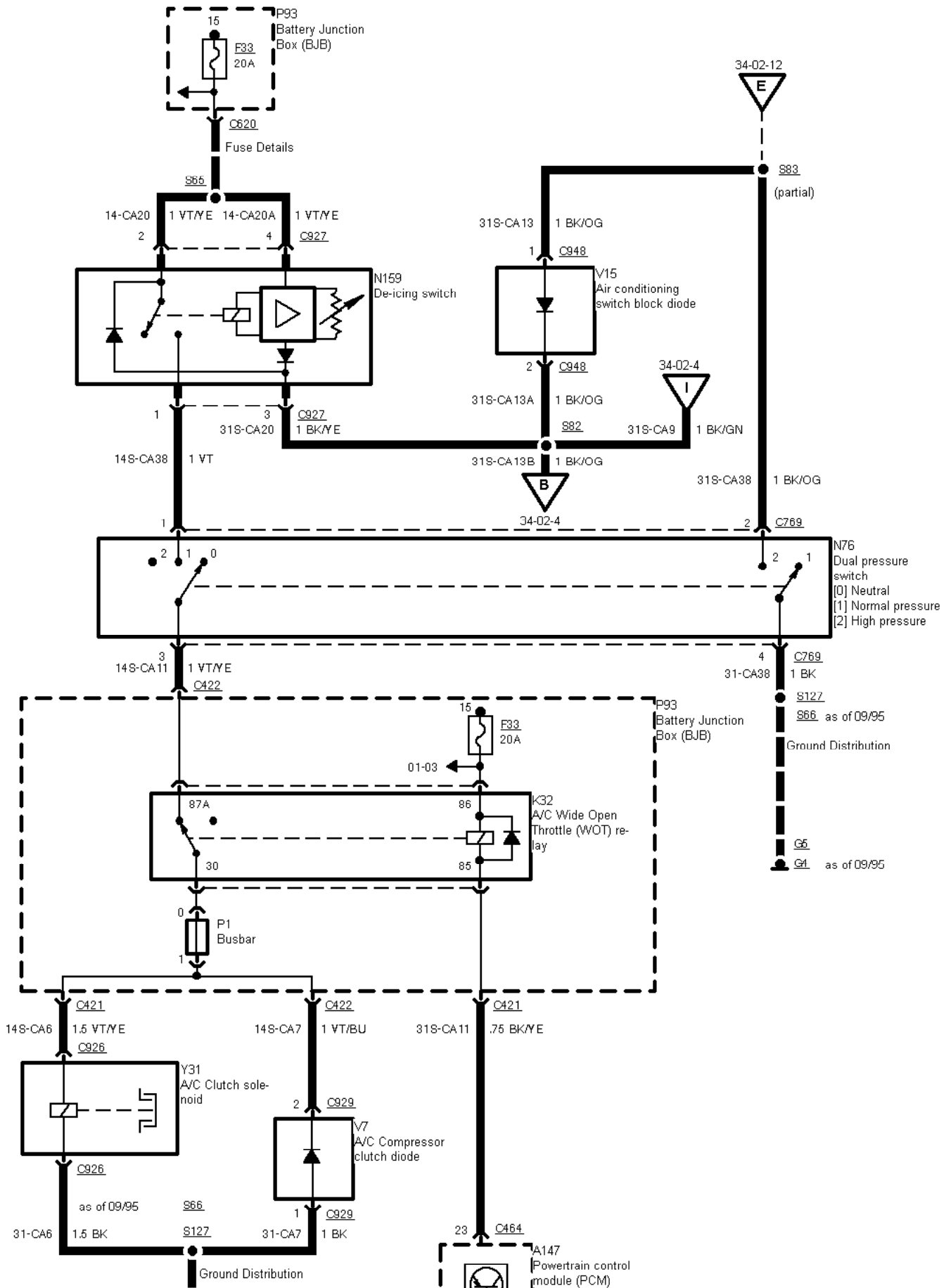

34-02-007 , Air Conditioning , Without SATC module, TCI Diesel before 02/95 and as of 09/95, TCI Diesel without PATS from 02/95 to 09/95



 G6
G4 as of 09/95

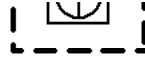

34-02-008 , Air Conditioning , Without SATC module, TCI Diesel with PATS from 02/95 to 09/95

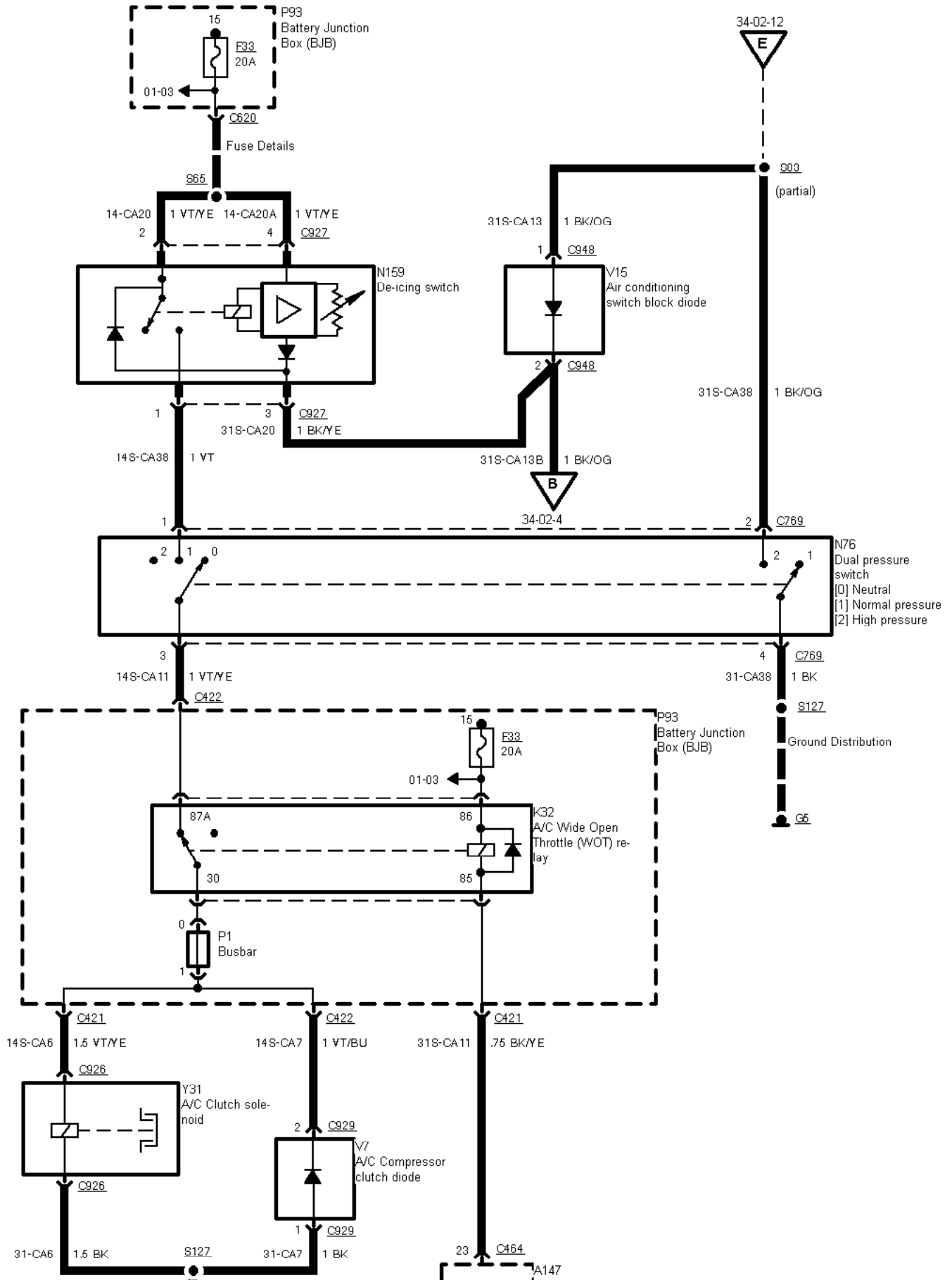

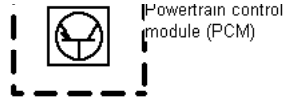
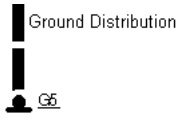

34-02-009 , Air Conditioning , Without SATC module, 2,9 I V6 12V

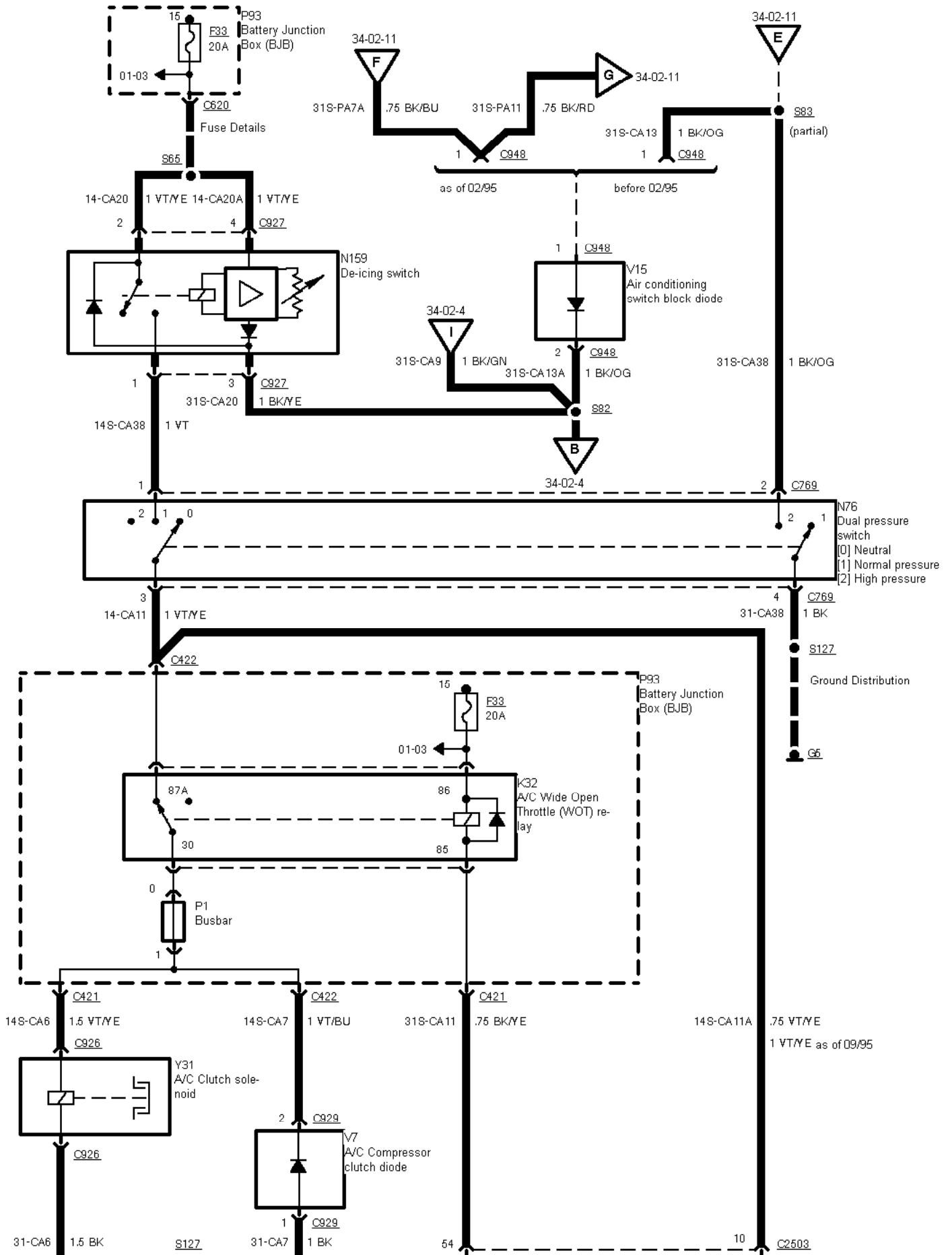

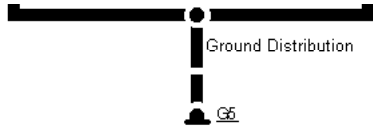

34-02-010 , Air Conditioning , Engine cooling fan, except TCI Diesel, except 2,9 I V6 12V

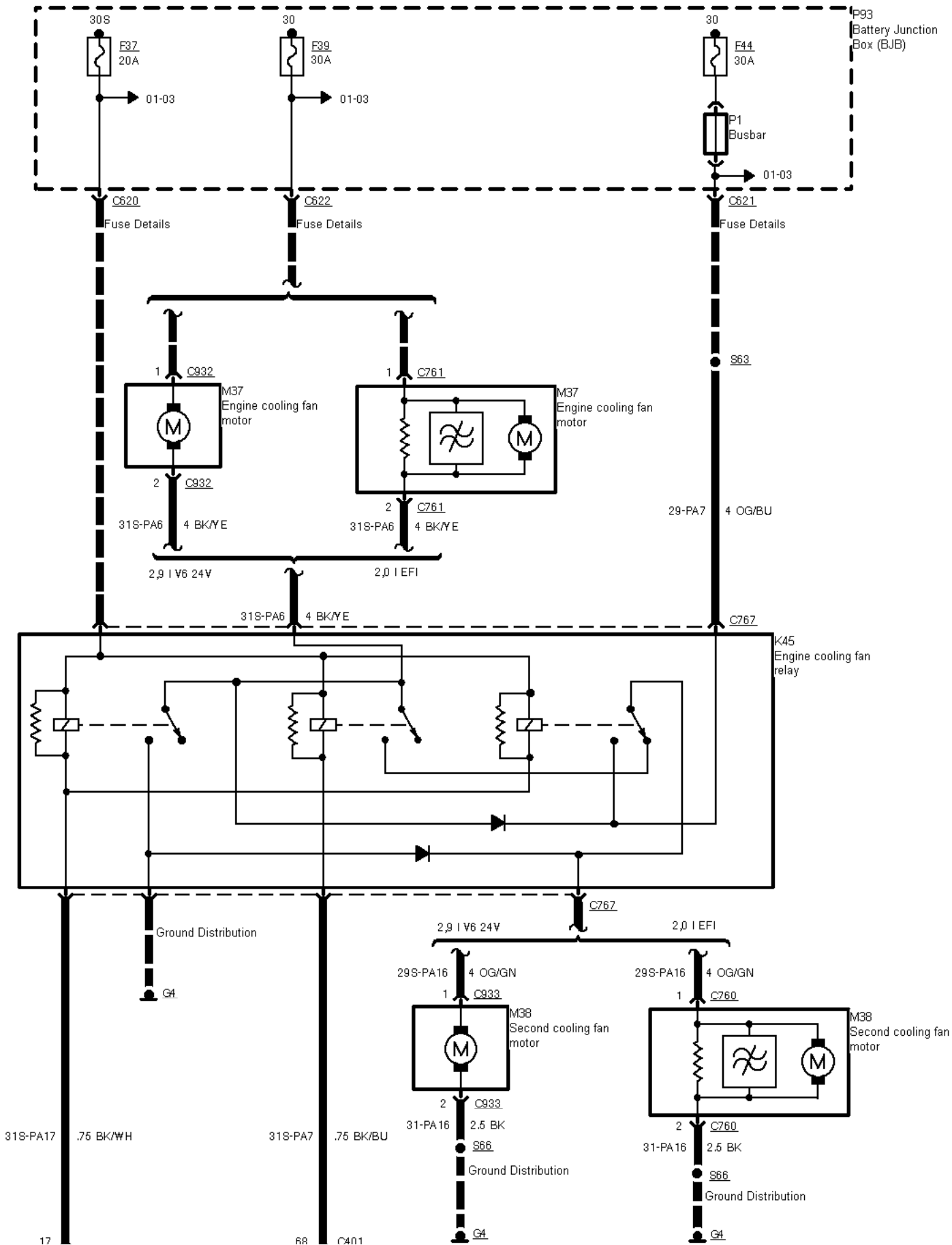

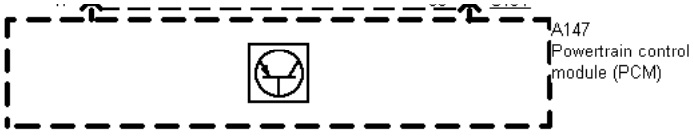

34-02-011 , Air Conditioning , Engine cooling fan, 2,9 I V6 12V

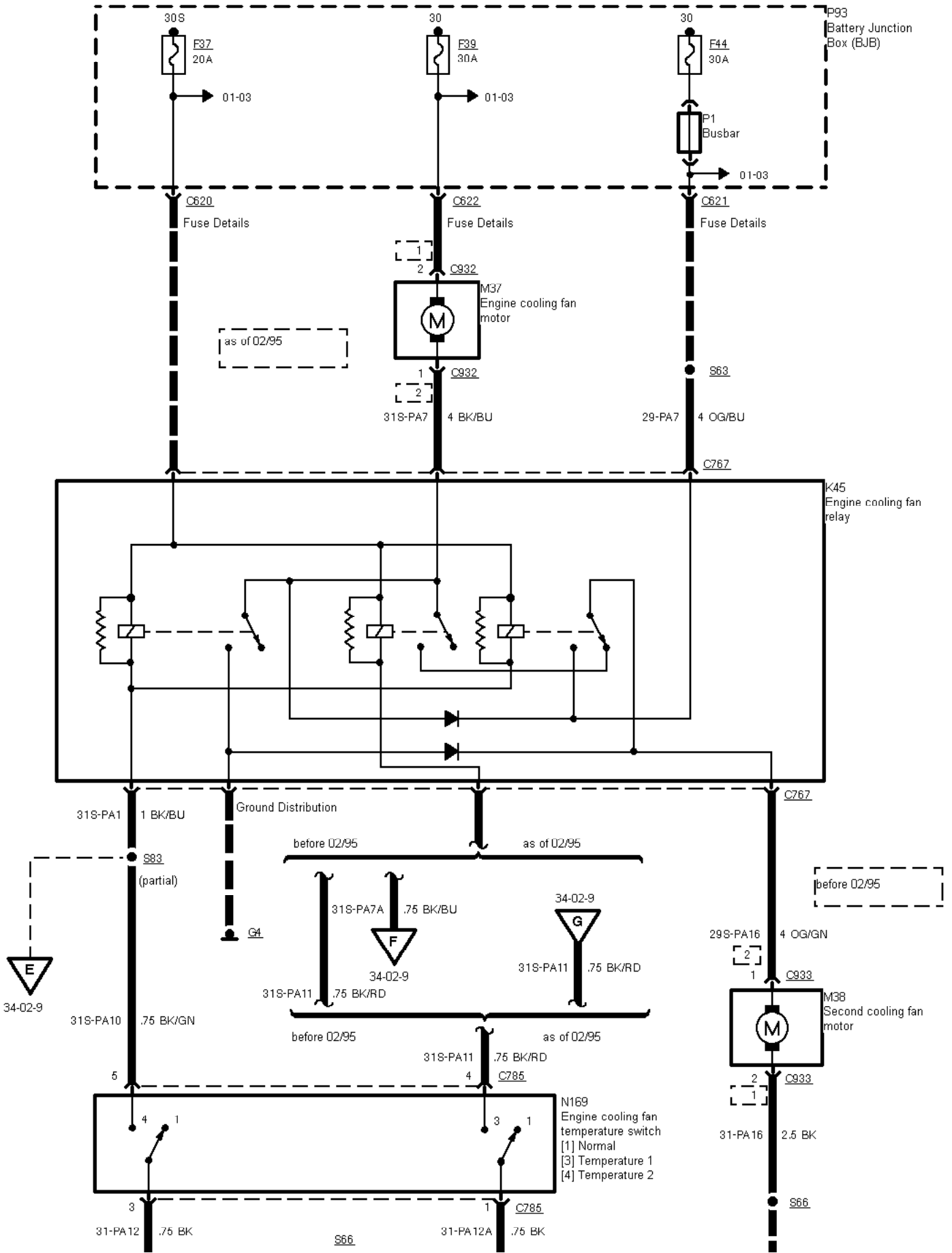

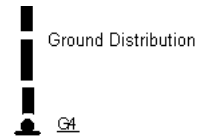
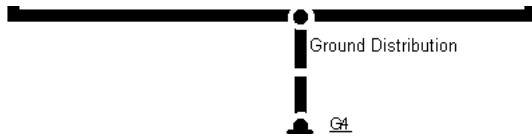

34-02-012 , Air Conditioning , Engine cooling fan, TCI Diesel

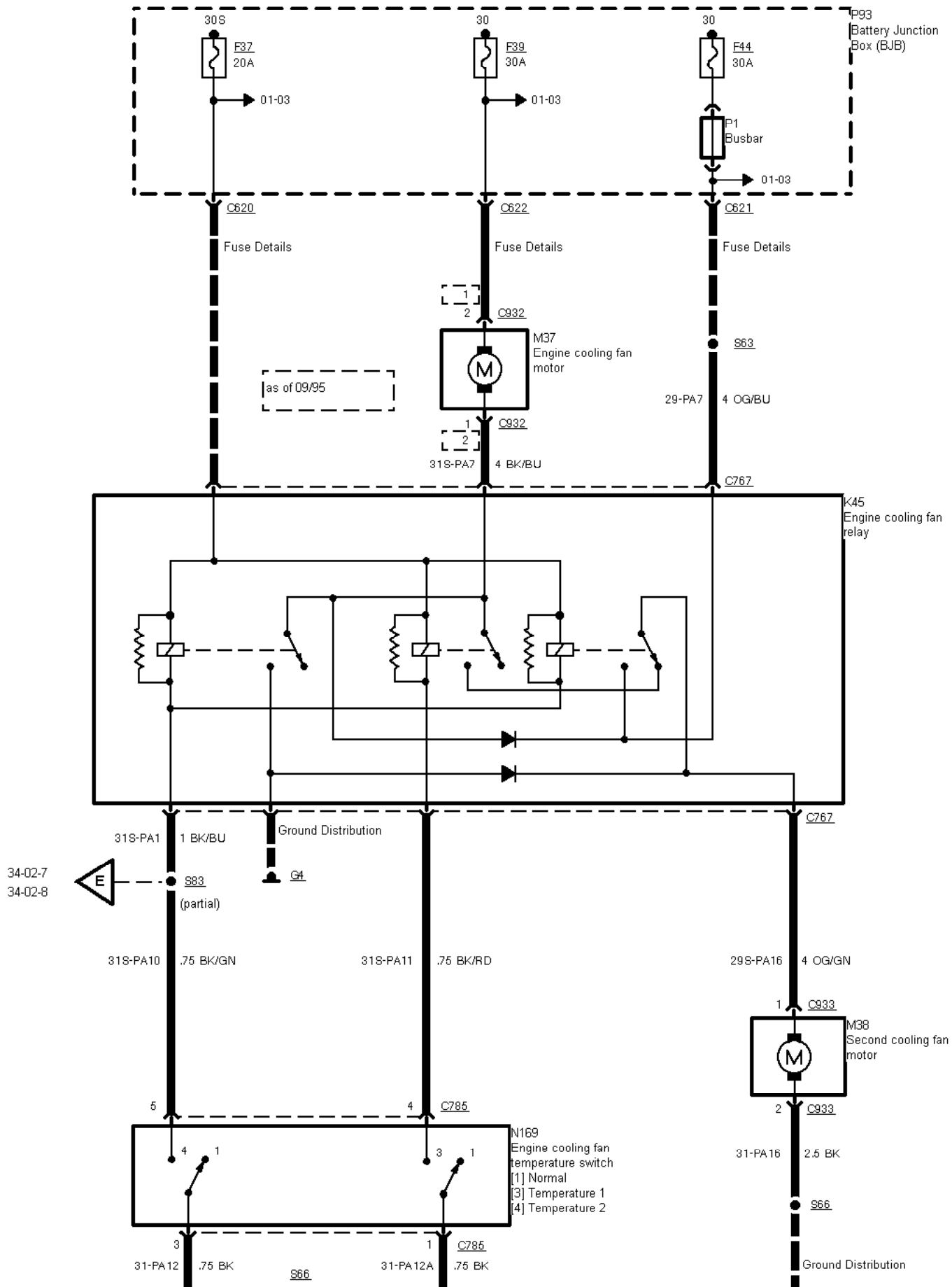

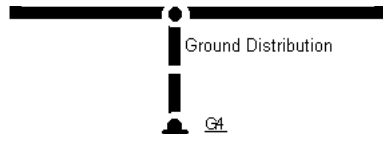

2 Circuit Description
