

34-04-001 , Air Conditioning with SATC , Power, heater blower motor

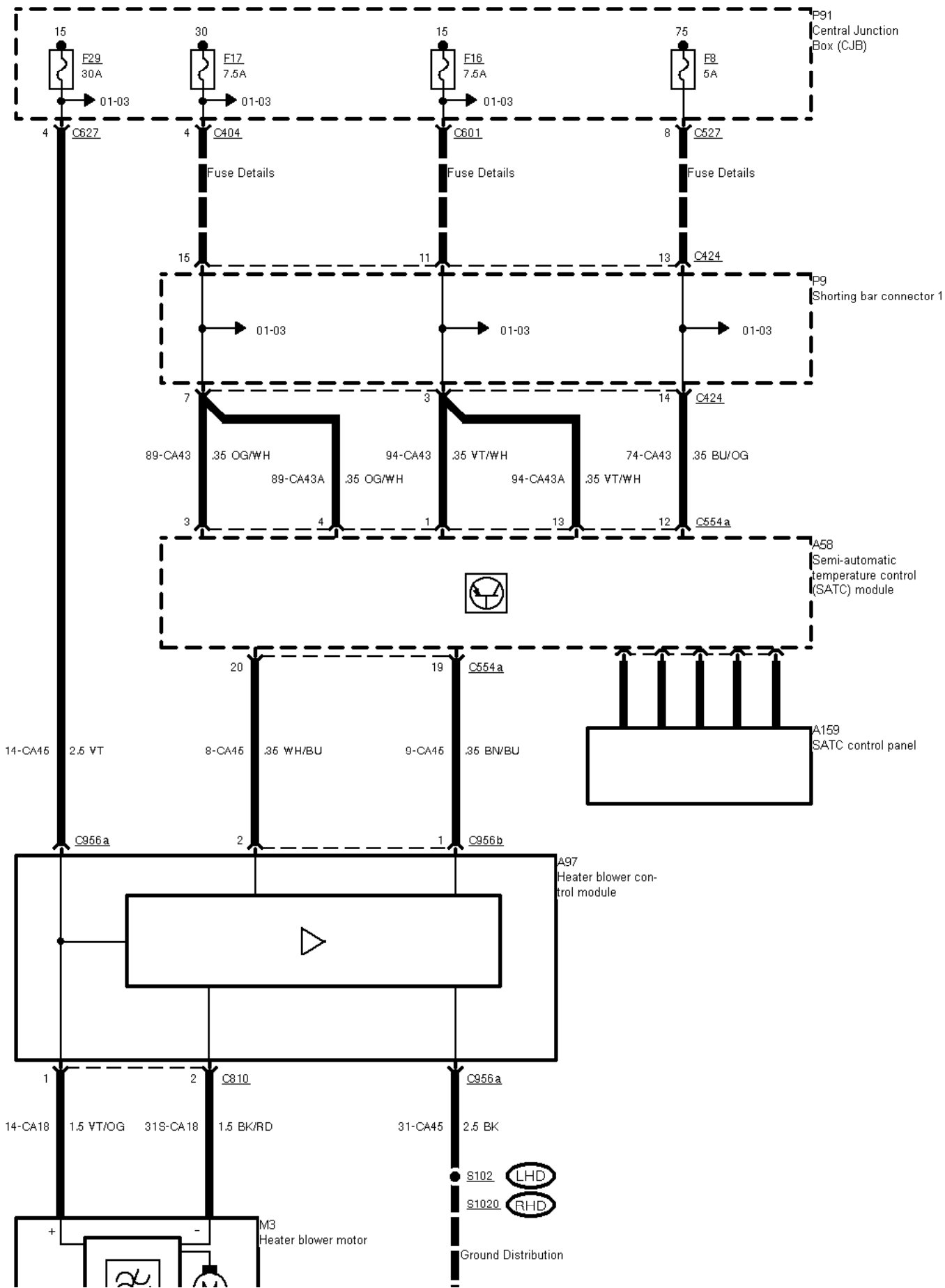

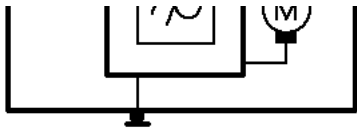

34-04-002 , Air Conditioning with SATC , Sensors

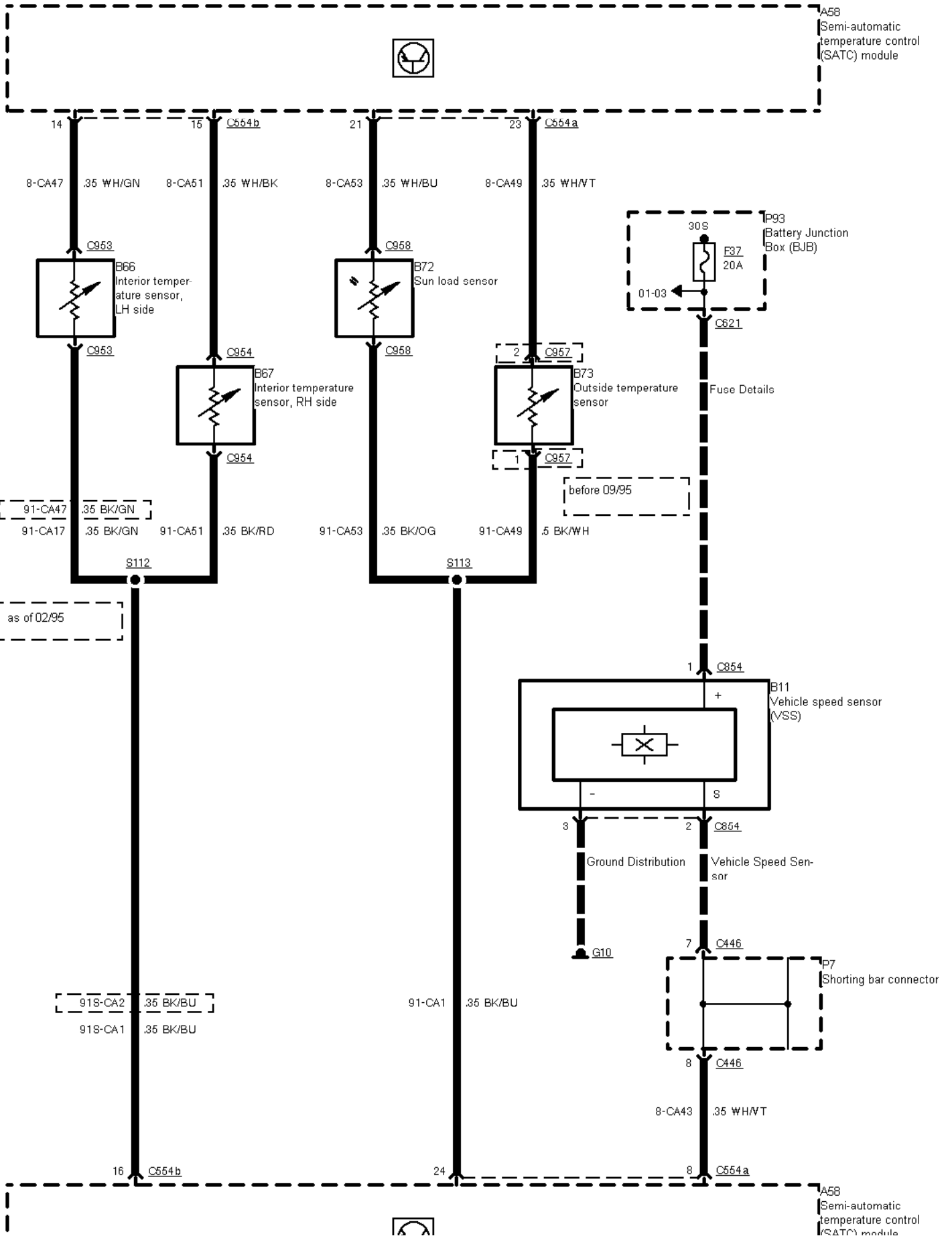



quantity module

34-04-003 , Air Conditioning with SATC , Door motors

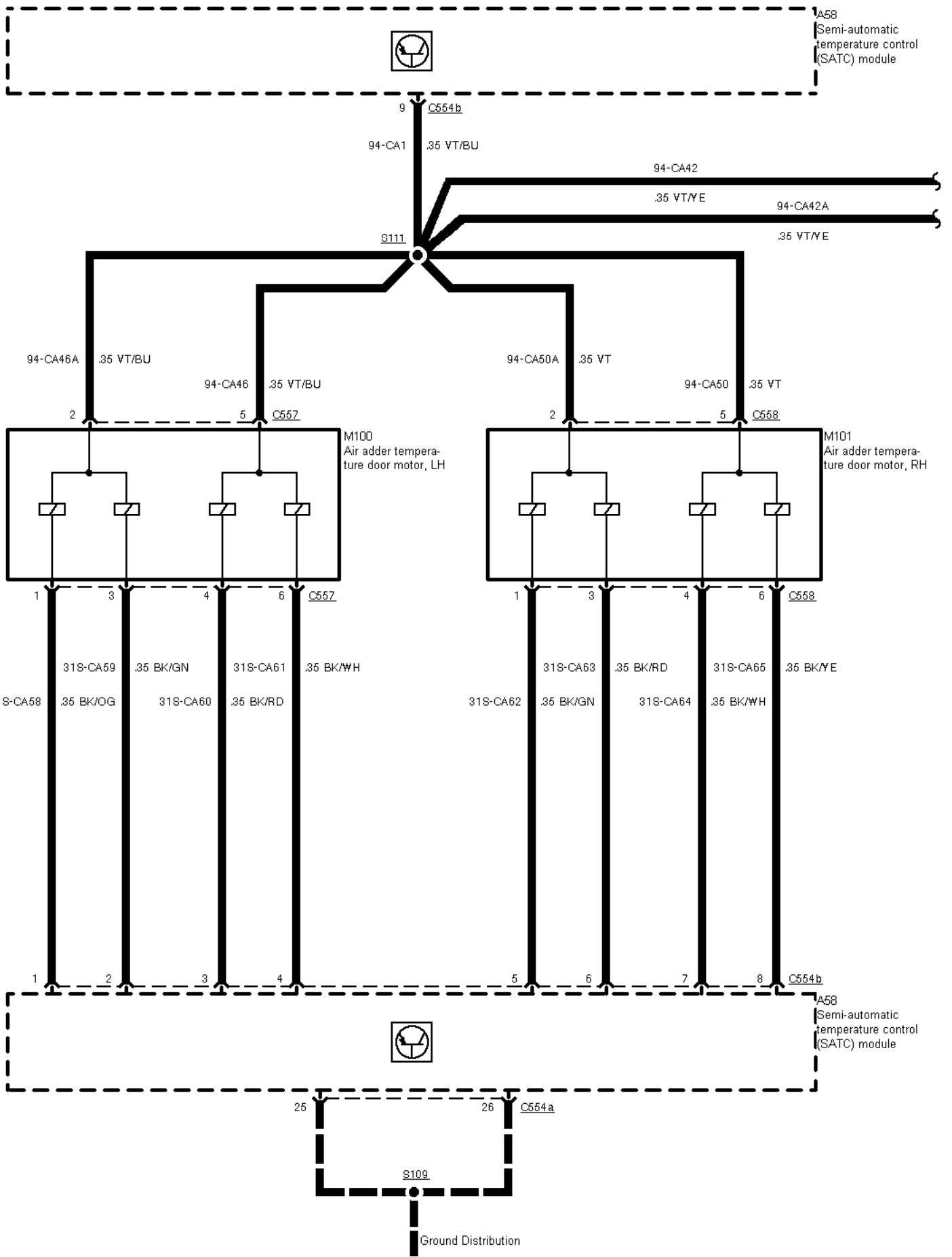

A58
Semi-automatic
temperature control
(SATC) module



9 C554b

94-CA1 .35 VT/BU

94-CA42

.35 VT/E

94-CA42A

.35 VT/E

S111

94-CA46A .35 VT/BU

94-CA46 .35 VT/BU

94-CA50A .35 VT

94-CA50 .35 VT

2

5

C557

2

5

C558

M100
Air adder tempera-
ture door motor, LH

M101
Air adder tempera-
ture door motor, RH

1

3

4

6

C557

1

3

4

6

C558

31S-CA59 .35 BK/GN

31S-CA61 .35 BK/WH

31S-CA63 .35 BK/RD

31S-CA65 .35 BK/YE

31S-CA58 .35 BK/OG

31S-CA60 .35 BK/RD

31S-CA62 .35 BK/GN

31S-CA64 .35 BK/WH

1

2

3

4

5

6

7

8

C554b

A58
Semi-automatic
temperature control
(SATC) module



25

26

C554a

S109

Ground Distribution



34-04-004 , Air Conditioning with SATC , Door motors

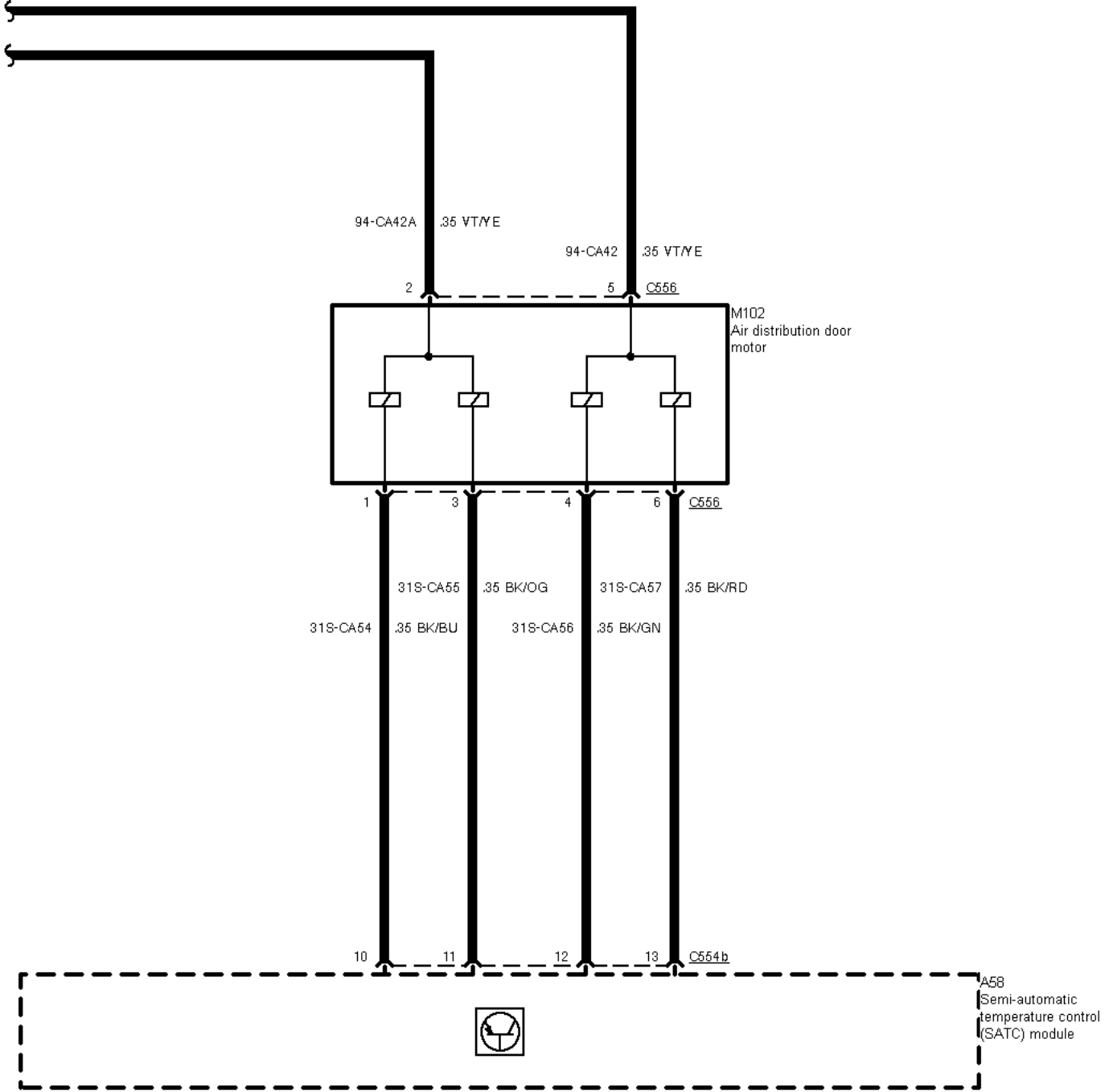

34-04-005 , Air Conditioning with SATC

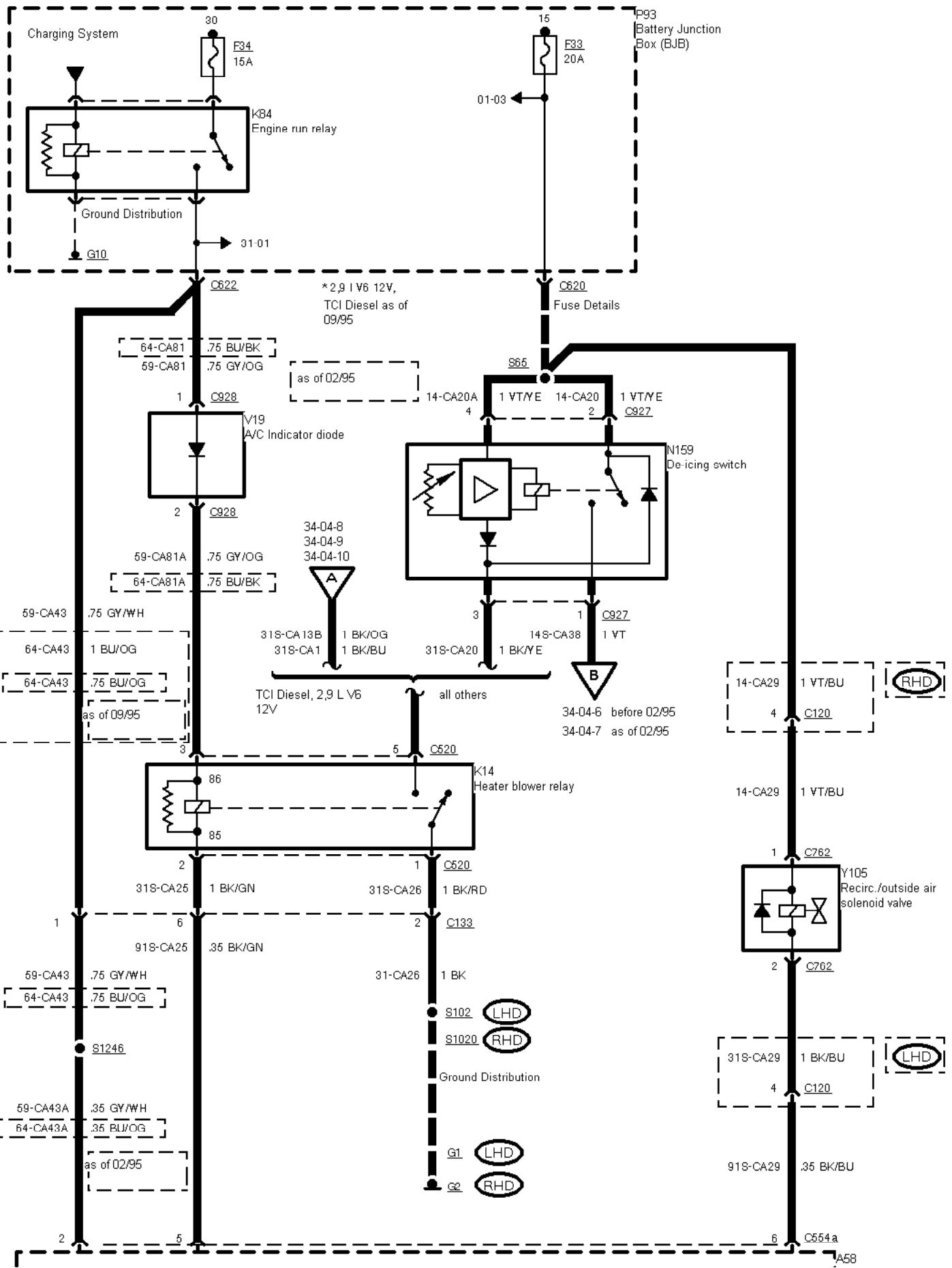



Semi-automatic
temperature control
(SATC) module

34-04-006 , Air Conditioning with SATC , Petrol engines before 02/95, except 2,9 I V6 12V

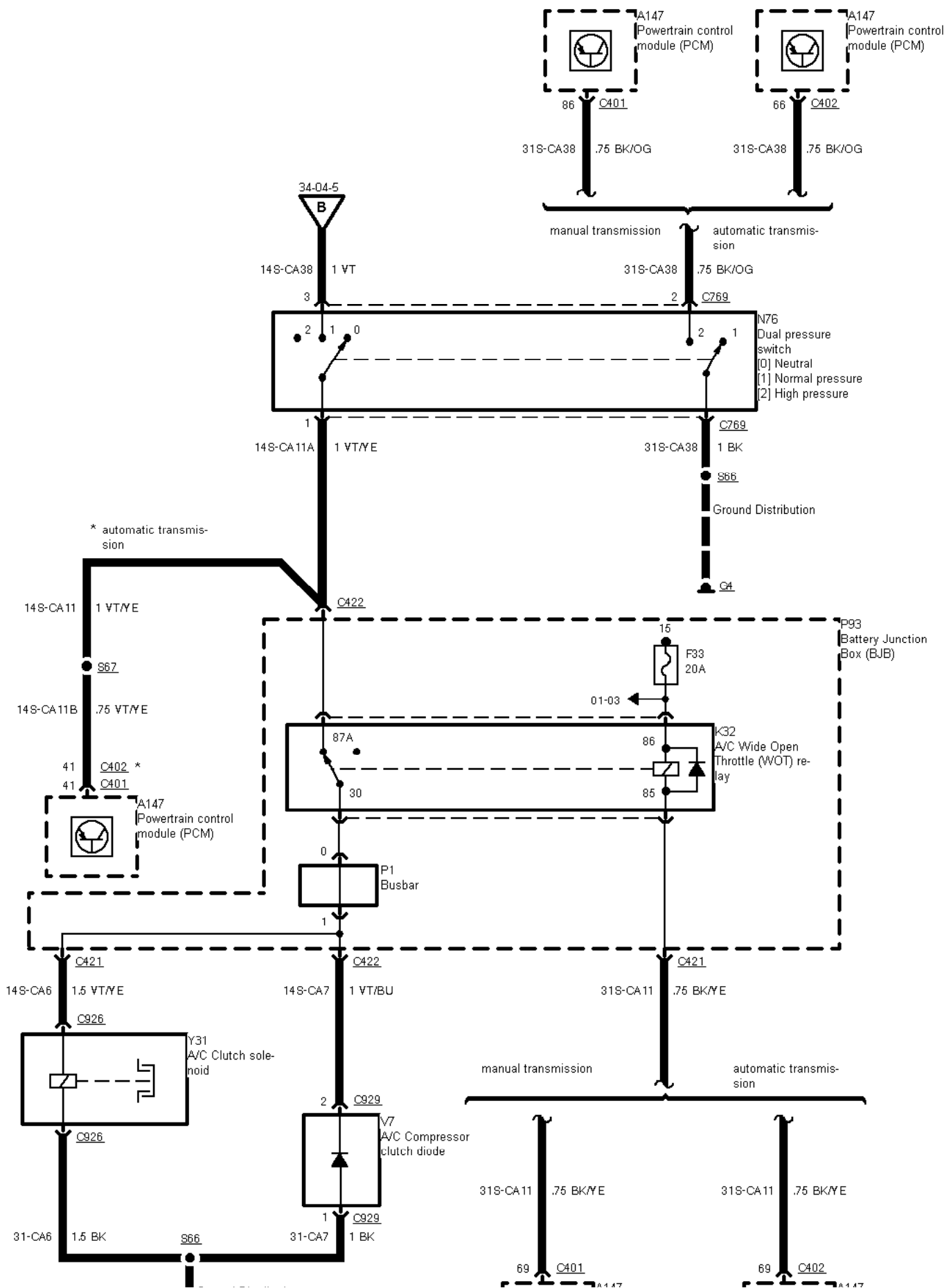

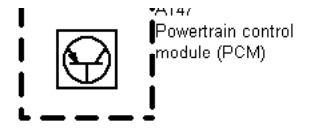
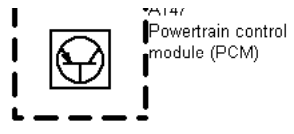
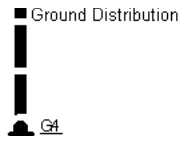

34-04-007 , Air Conditioning with SATC , Petrol engines as of 02/95, except 2,9 I V6 12V

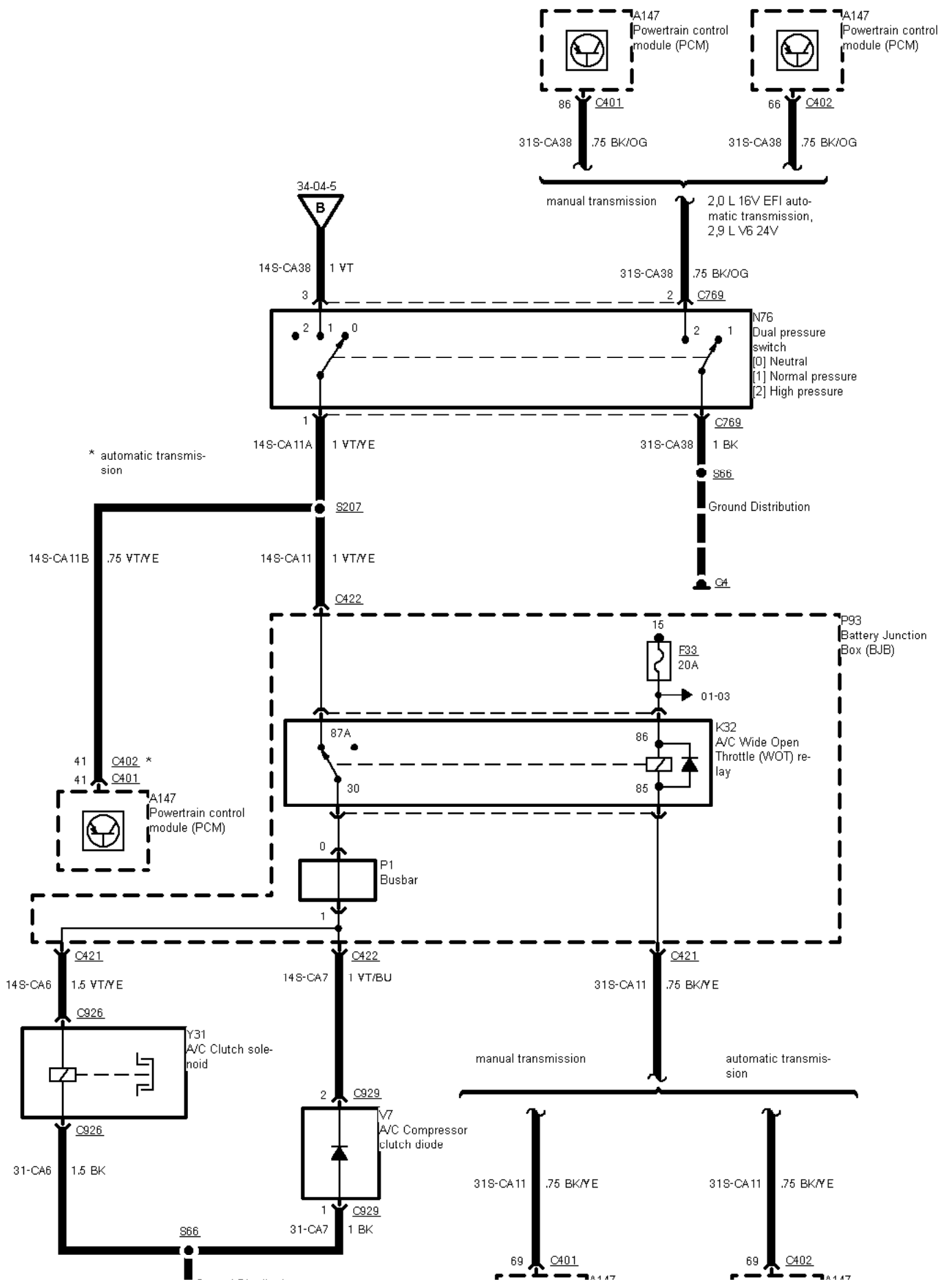

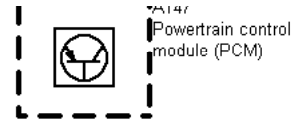
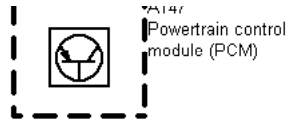
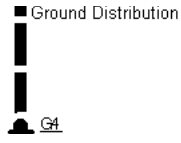

34-04-008 , Air Conditioning with SATC , TCI Diesel before 02/95 and as of 09/95, TCI Diesel without PATS from 02/95 to 09/95

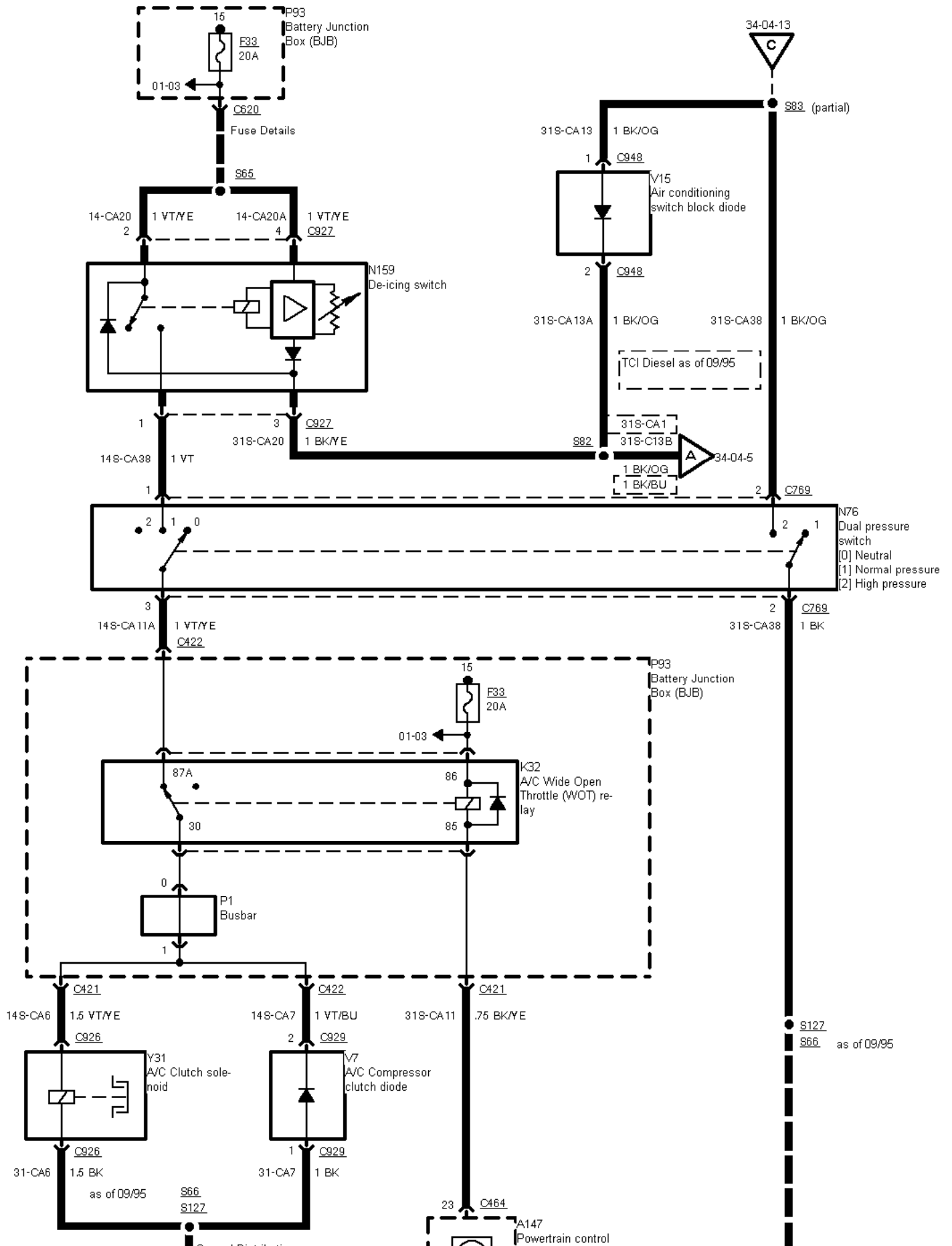

Ground Distribution
G5
G4 as of 09/95

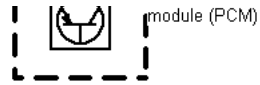

Ground Distribution
G5
G4 as of 09/95

34-04-009 , Air Conditioning with SATC , TCI Diesel with PATS from 02/95 to 09/95

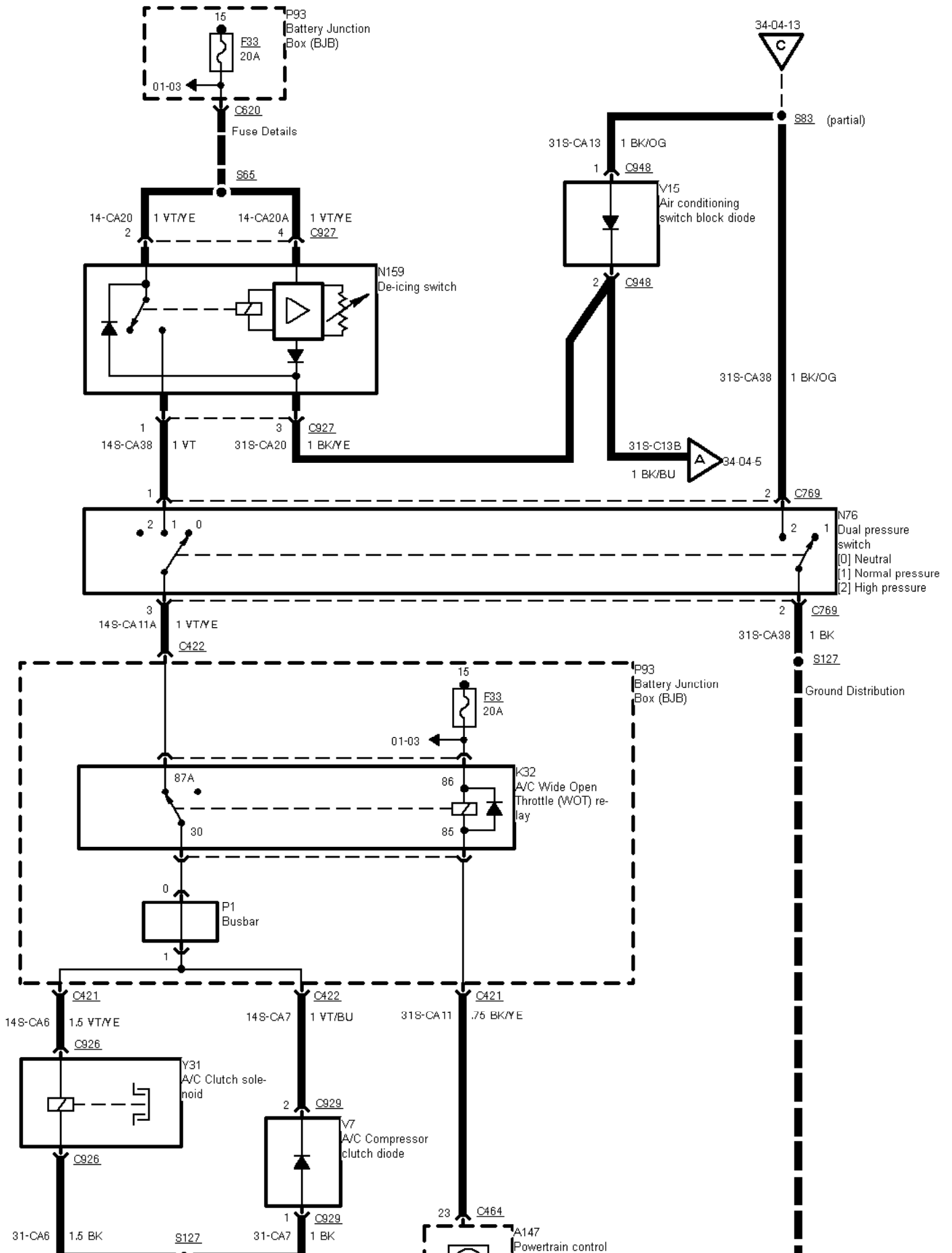

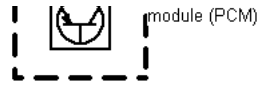
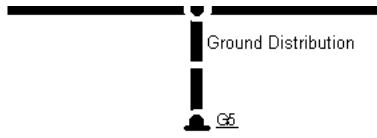

34-04-010 , Air Conditioning with SATC , 2,9 I V6 12V

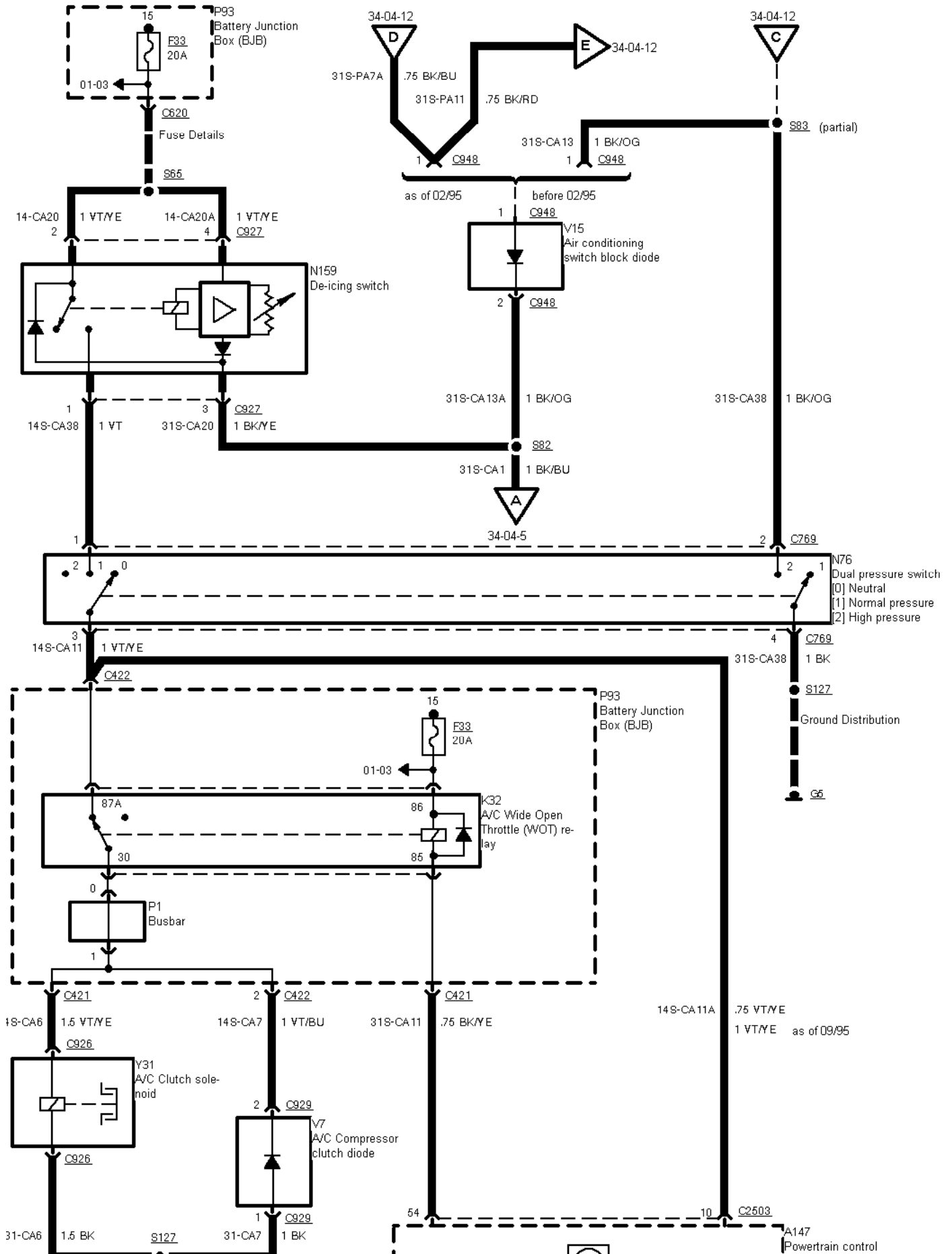

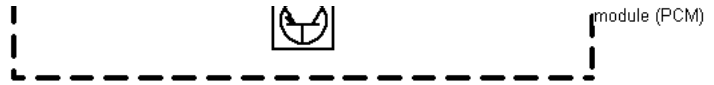
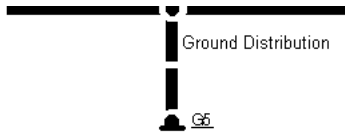

34-04-011 , Air Conditioning with SATC , Engine cooling fan, except TCI Diesel, except 2,9 I V6 12V

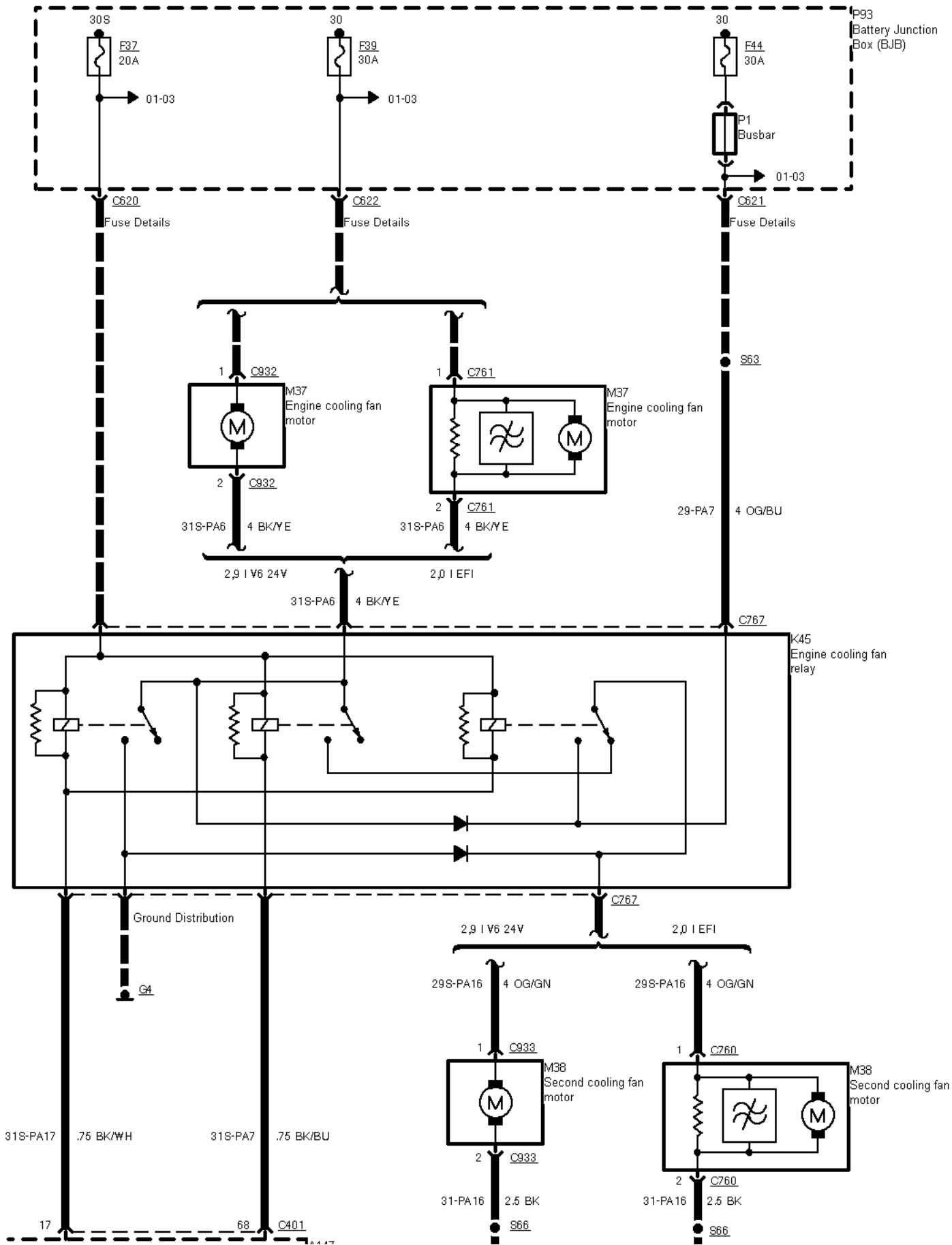

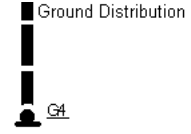
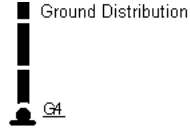
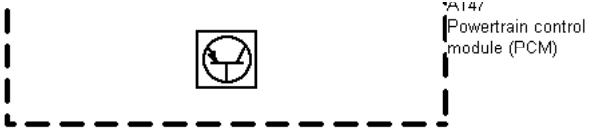

34-04-012 , Air Conditioning with SATC , Engine cooling fan, 2,9 I V6 12V

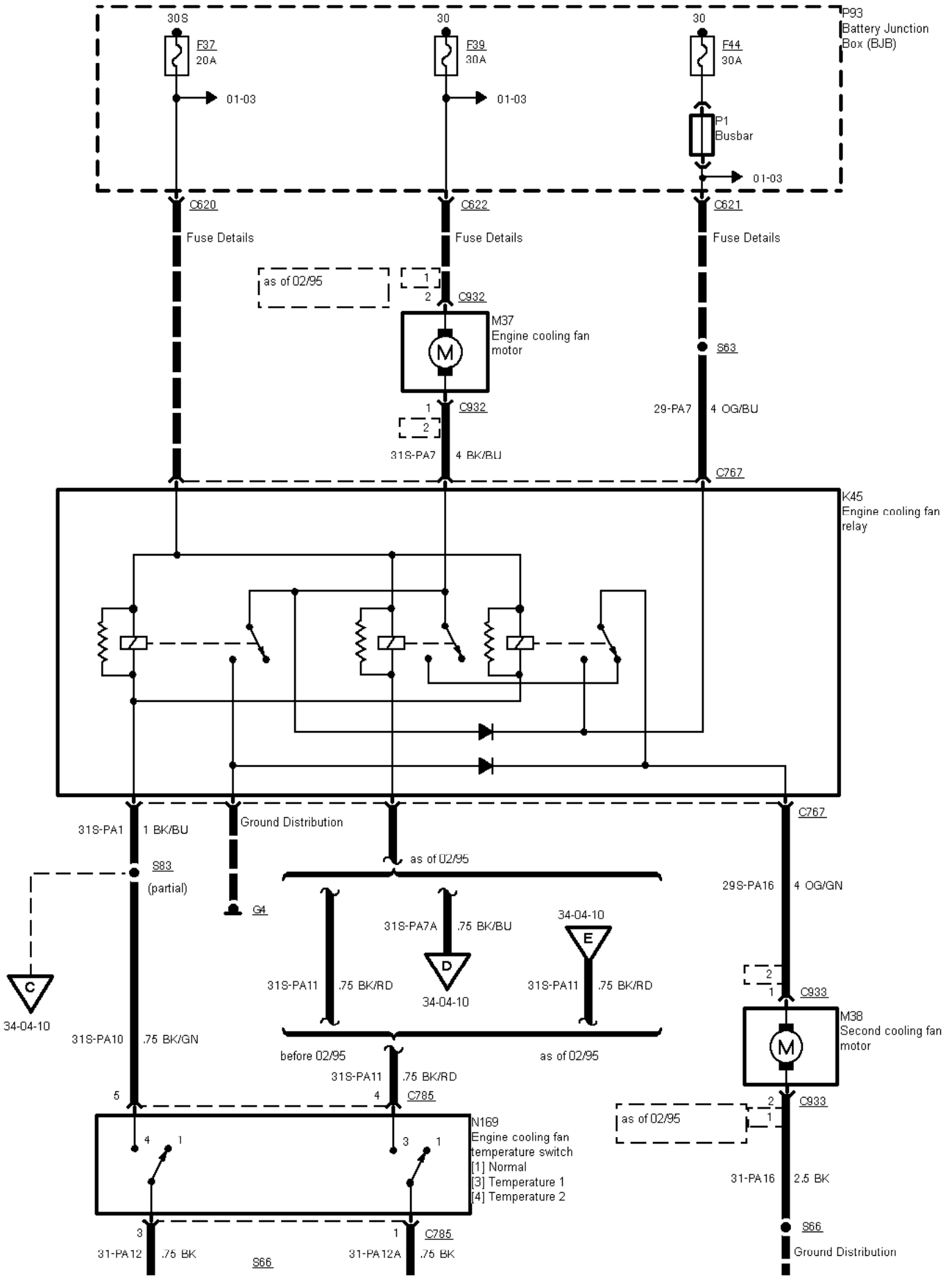

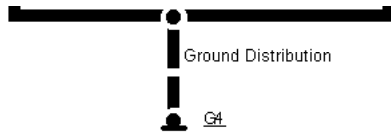

34-04-013 , Air Conditioning with SATC , Engine cooling fan, TCI Diesel

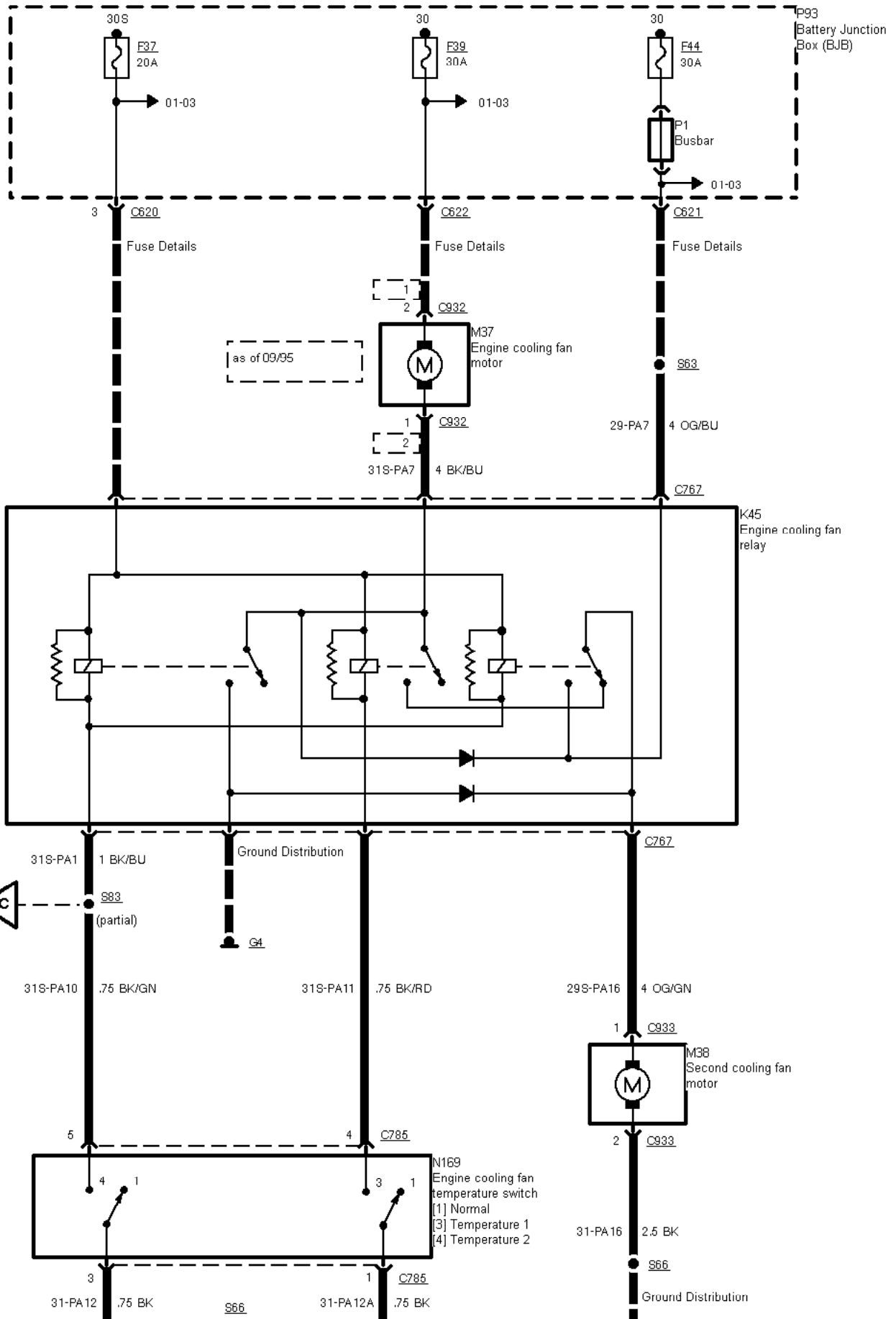

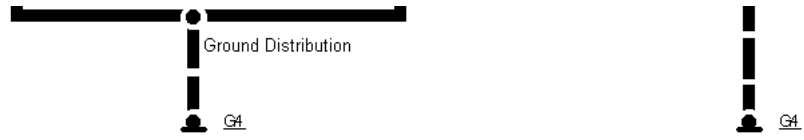

2 Circuit Description
