

01-04-002 , Ground Distribution , Ground G1 Lower option content, without multiplex, as of 02/95

LHD

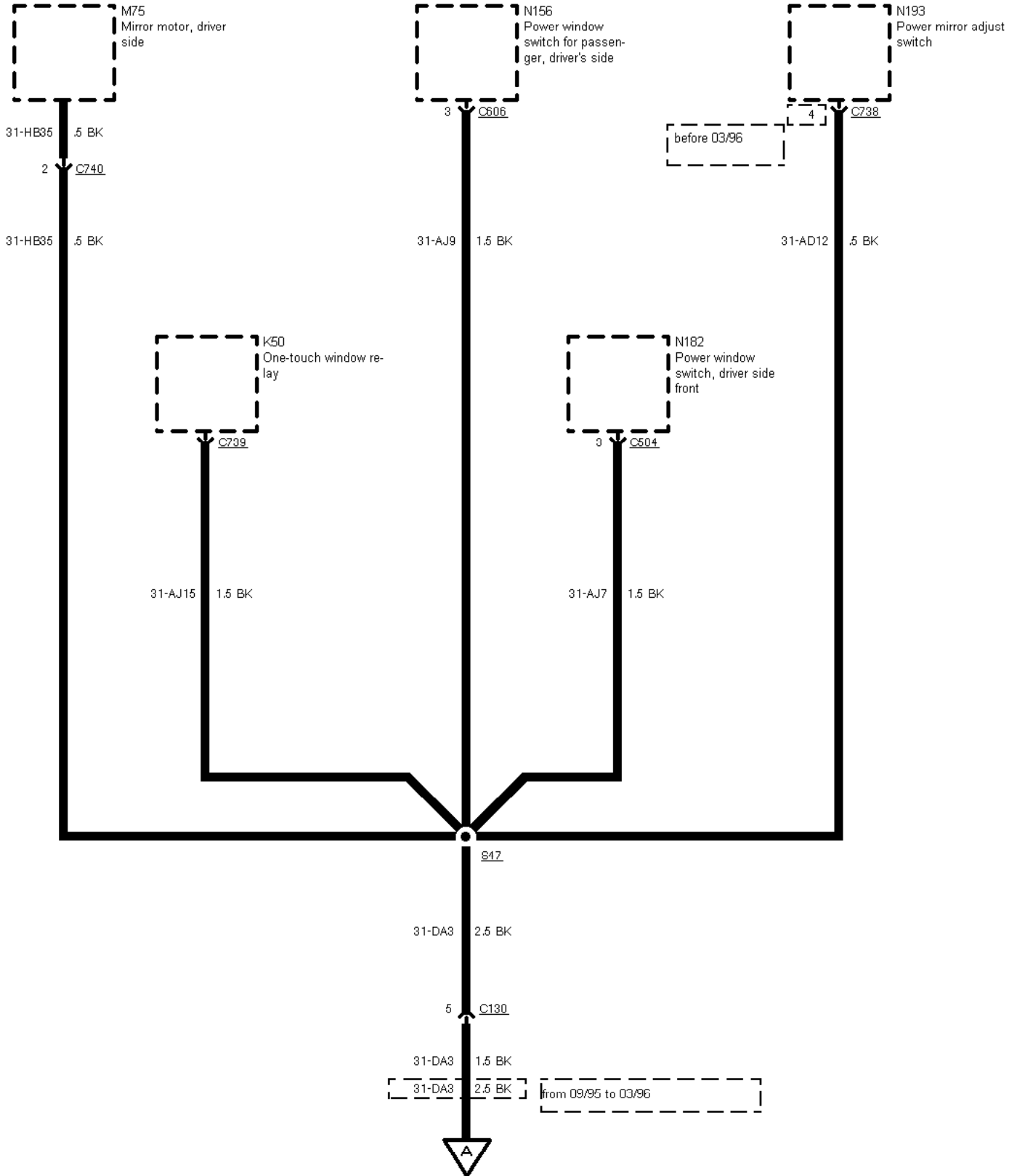

01-04-003 , Ground Distribution , Ground G1 Lower option content, without multiplex, Before 02/95

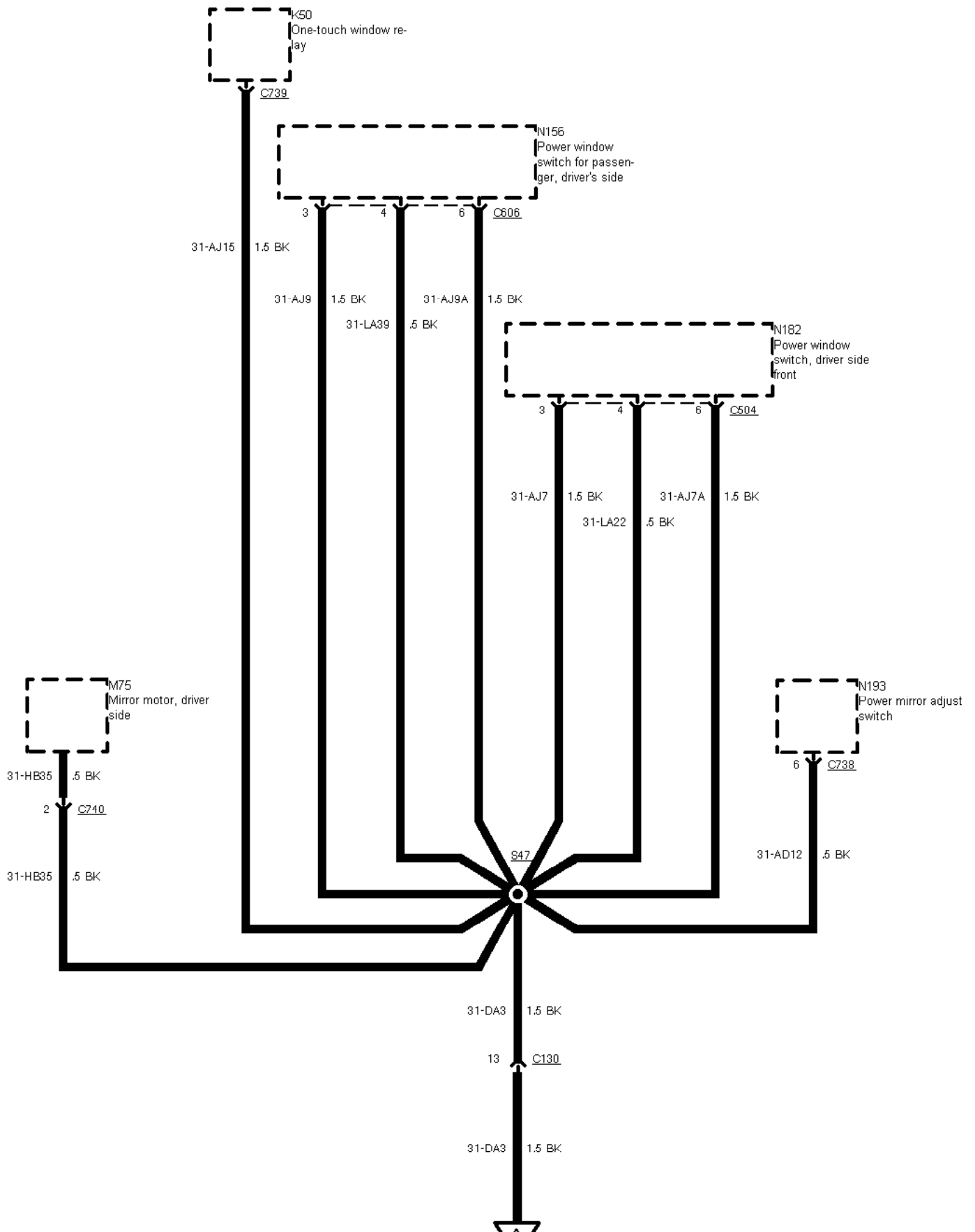

01-04-004 , Ground Distribution , Ground G1 Higher option content, with multiplex

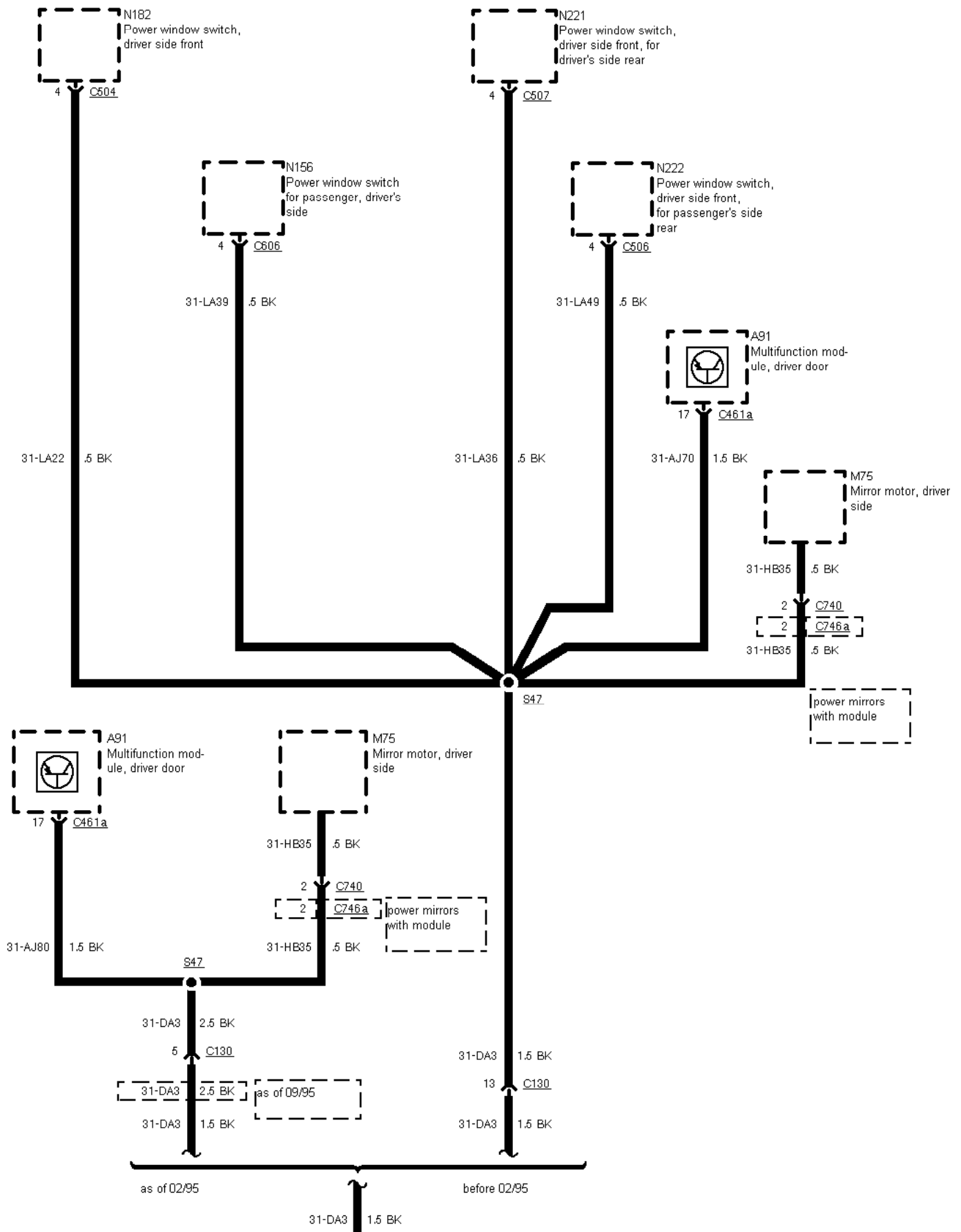



01-04-6

01-04-005 , Ground Distribution , Ground G1

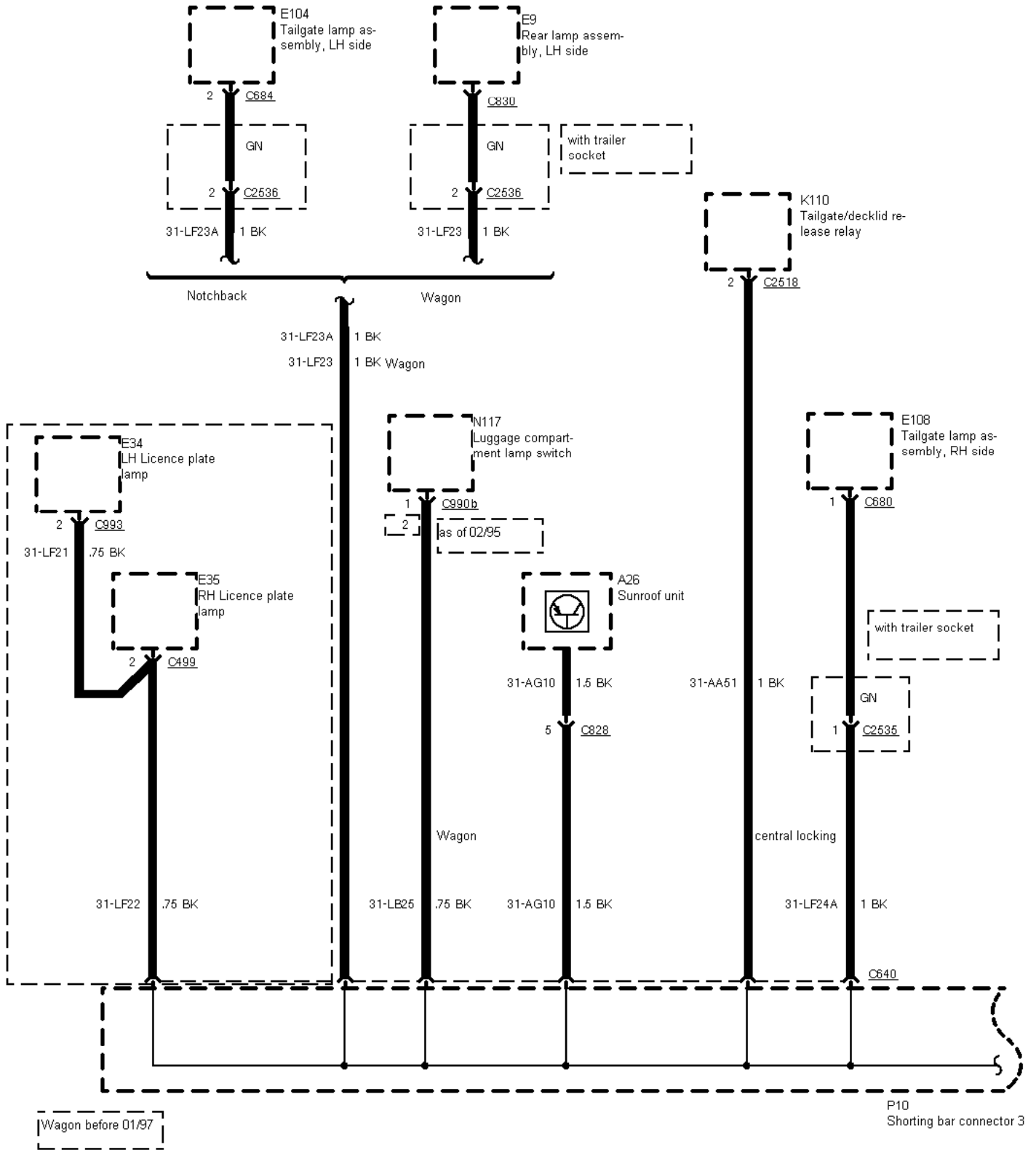

01-04-006 , Ground Distribution , Ground G1

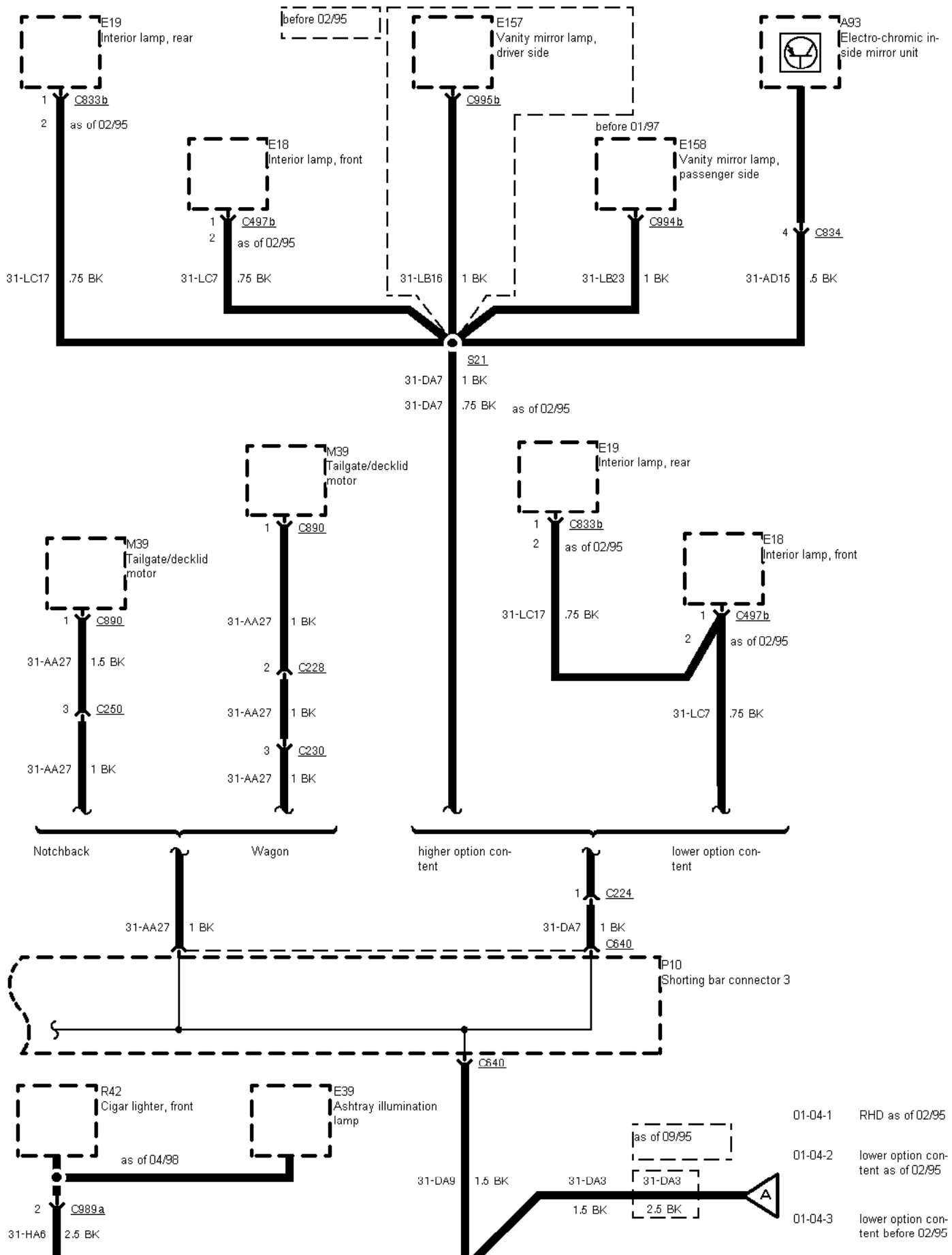



S4 (partial)

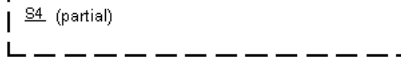

01-04-4 higher option content

01-04-7

01-04-007 , Ground Distribution , Ground G1

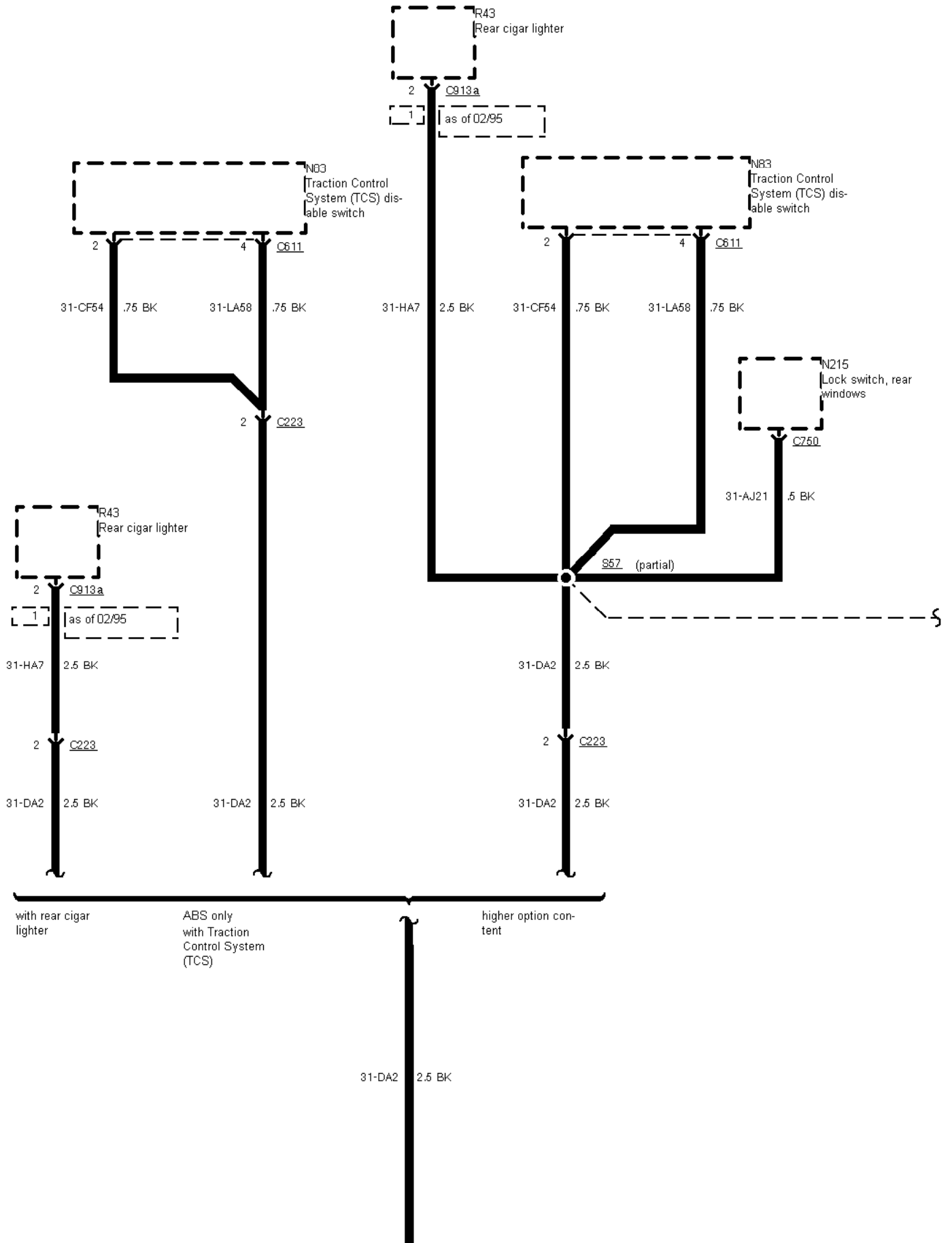

01-04-6



! S4 (partial)
●

5

01-04-008 , Ground Distribution , Ground G1

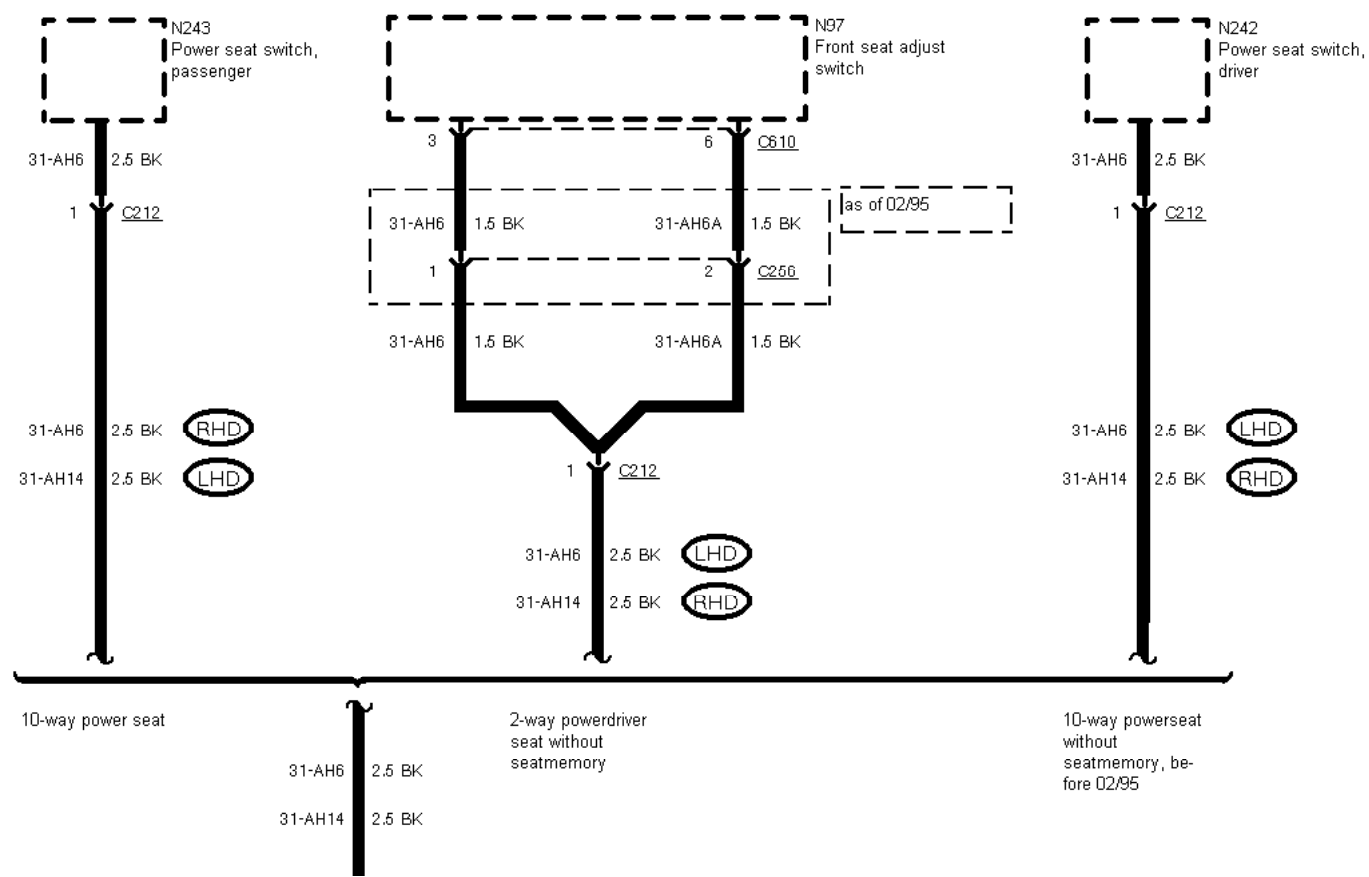
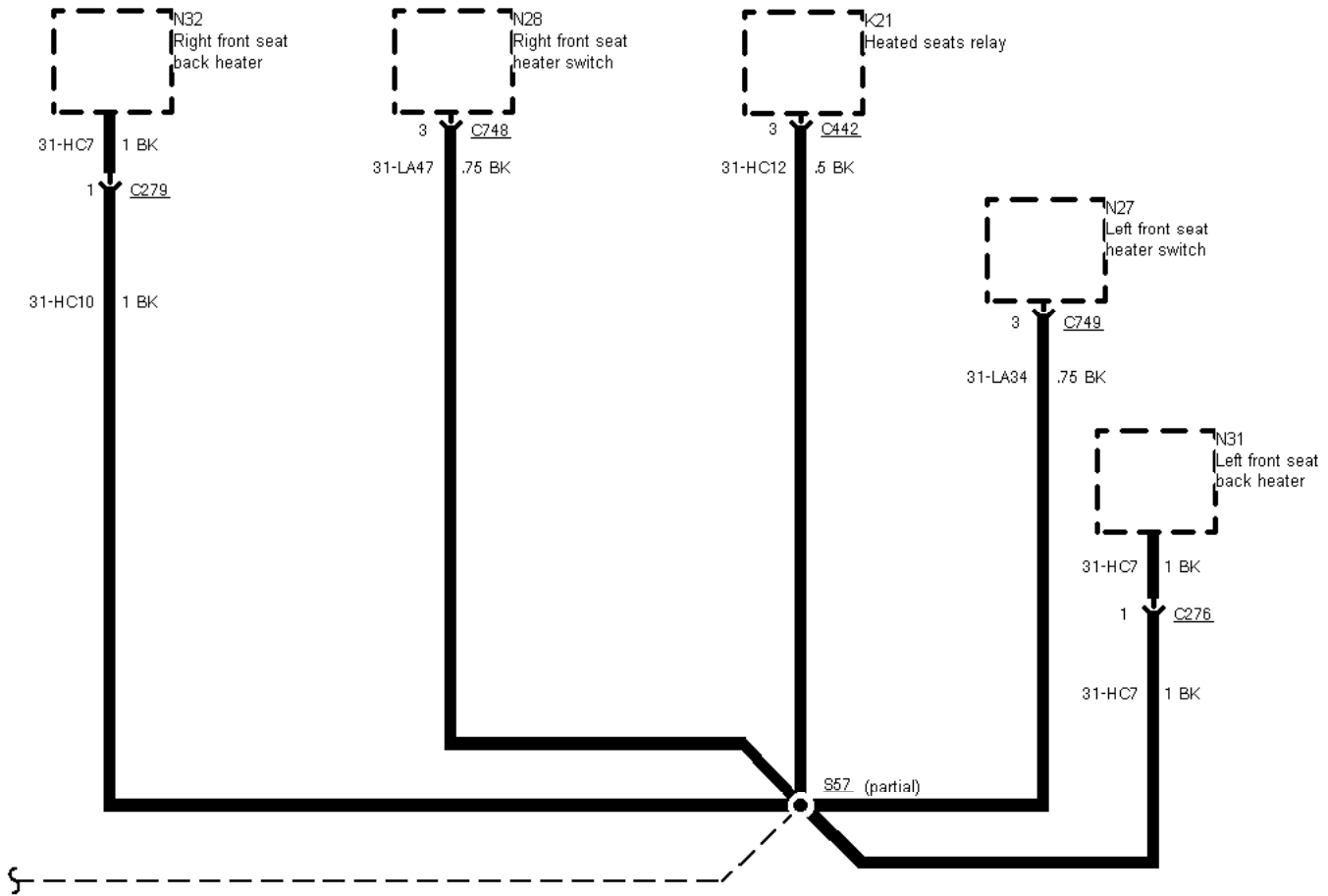

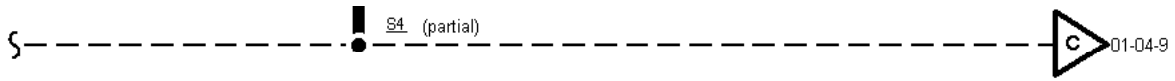

01-04-009 , Ground Distribution , Ground G1

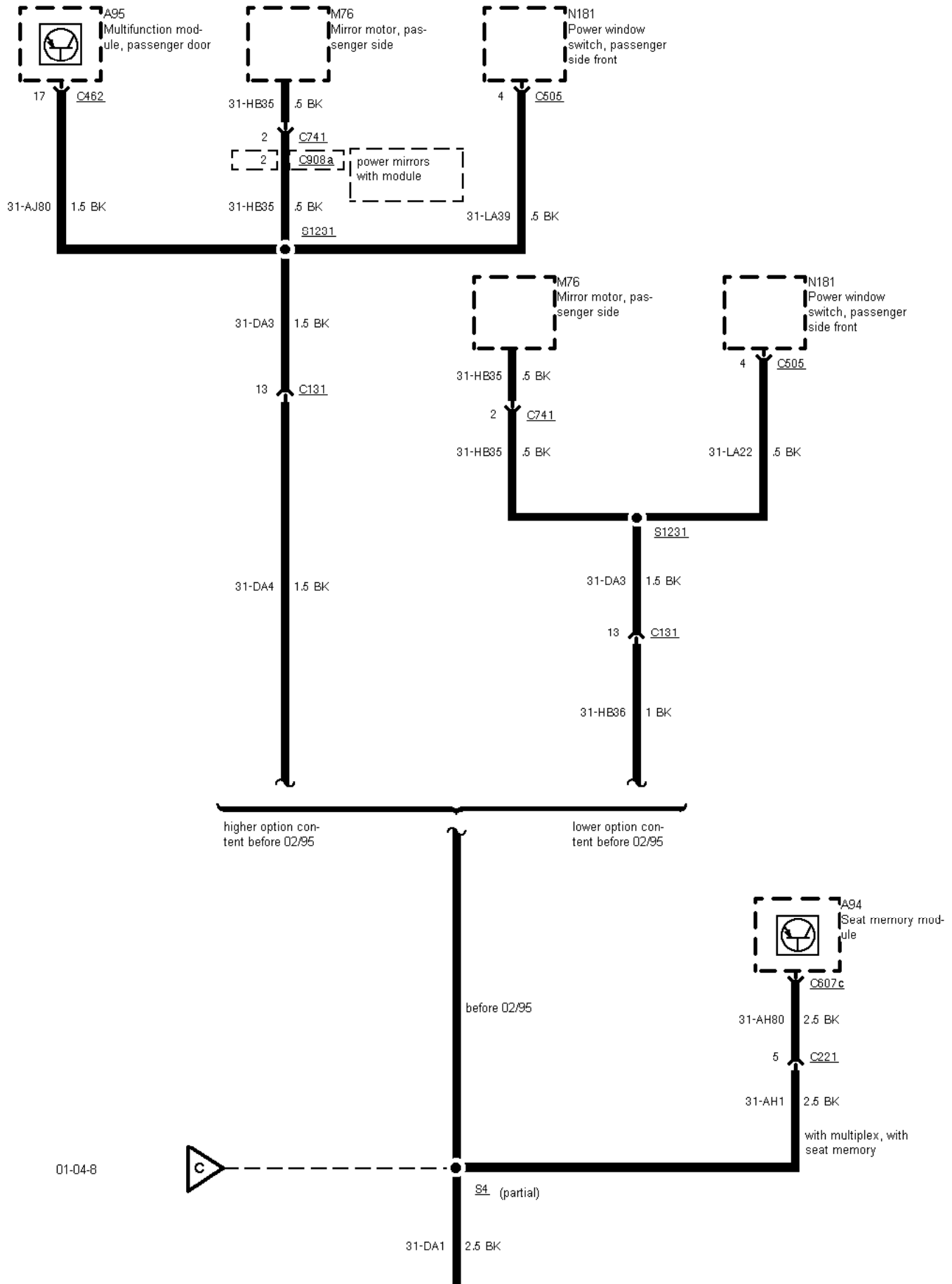



01-04-19

01-04-010 , Ground Distribution , Ground G1 Left-hand-drive vehicles

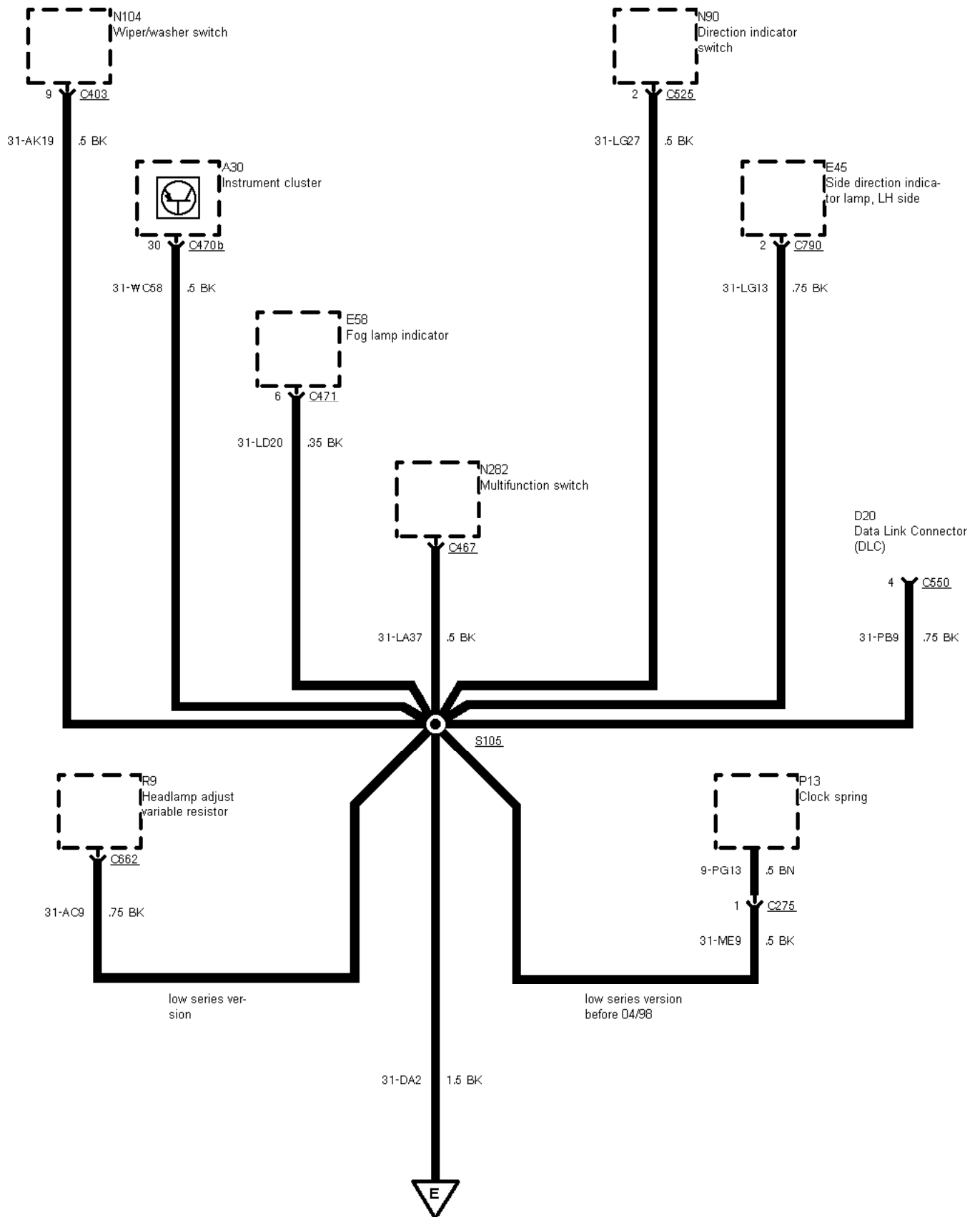

01-04-011 , Ground Distribution , Ground G1 Left-hand-drive vehicles, except low series version

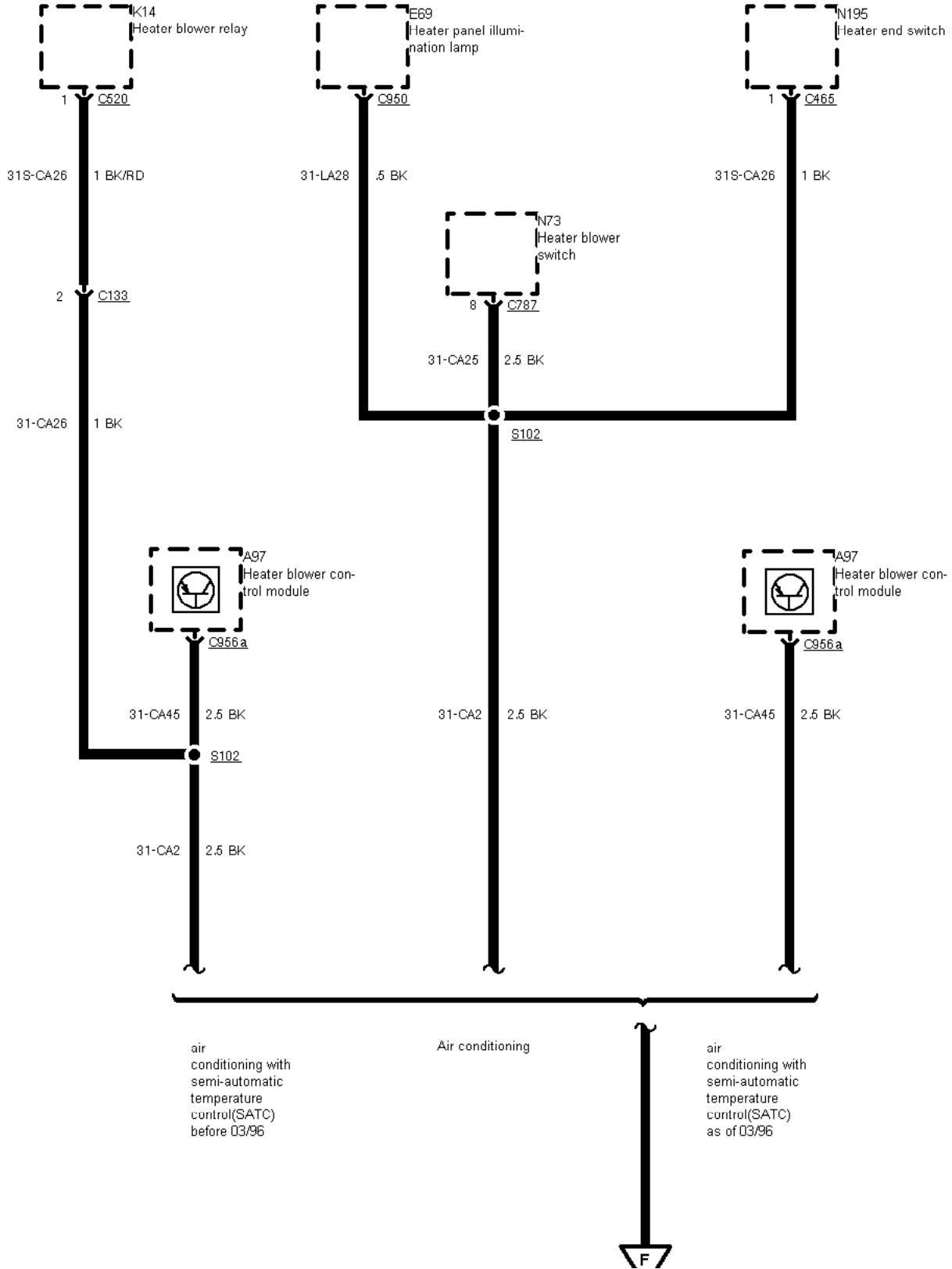



01-04-19

01-04-012 , Ground Distribution , Ground G1 Right-hand-drive vehicles, Taxi with overhead console

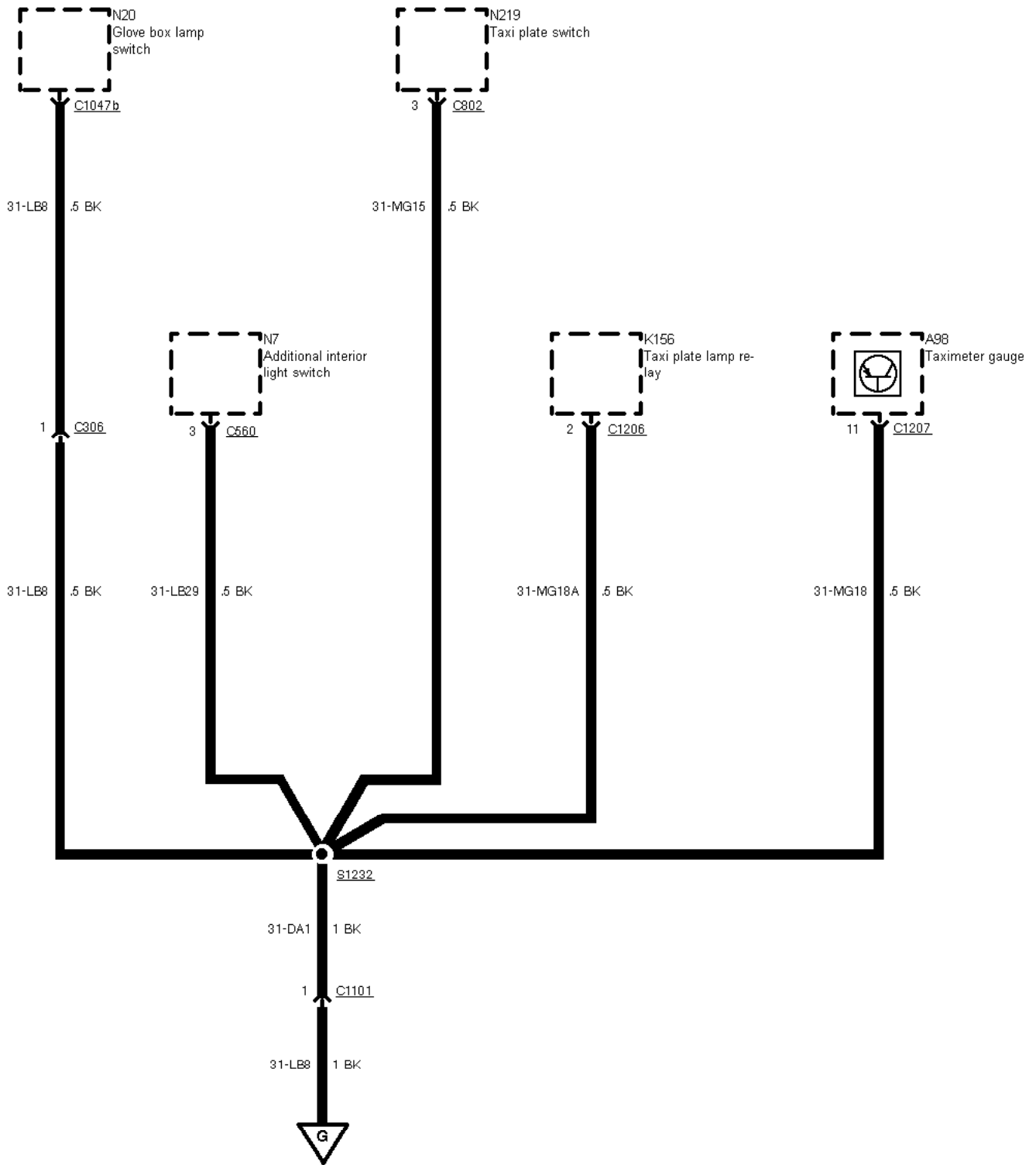

01-04-15 as of 09/95

01-04-15 as of 09/95

01-04-013 , Ground Distribution , Ground G1 Right-hand-drive vehicles, Taxi without overhead console

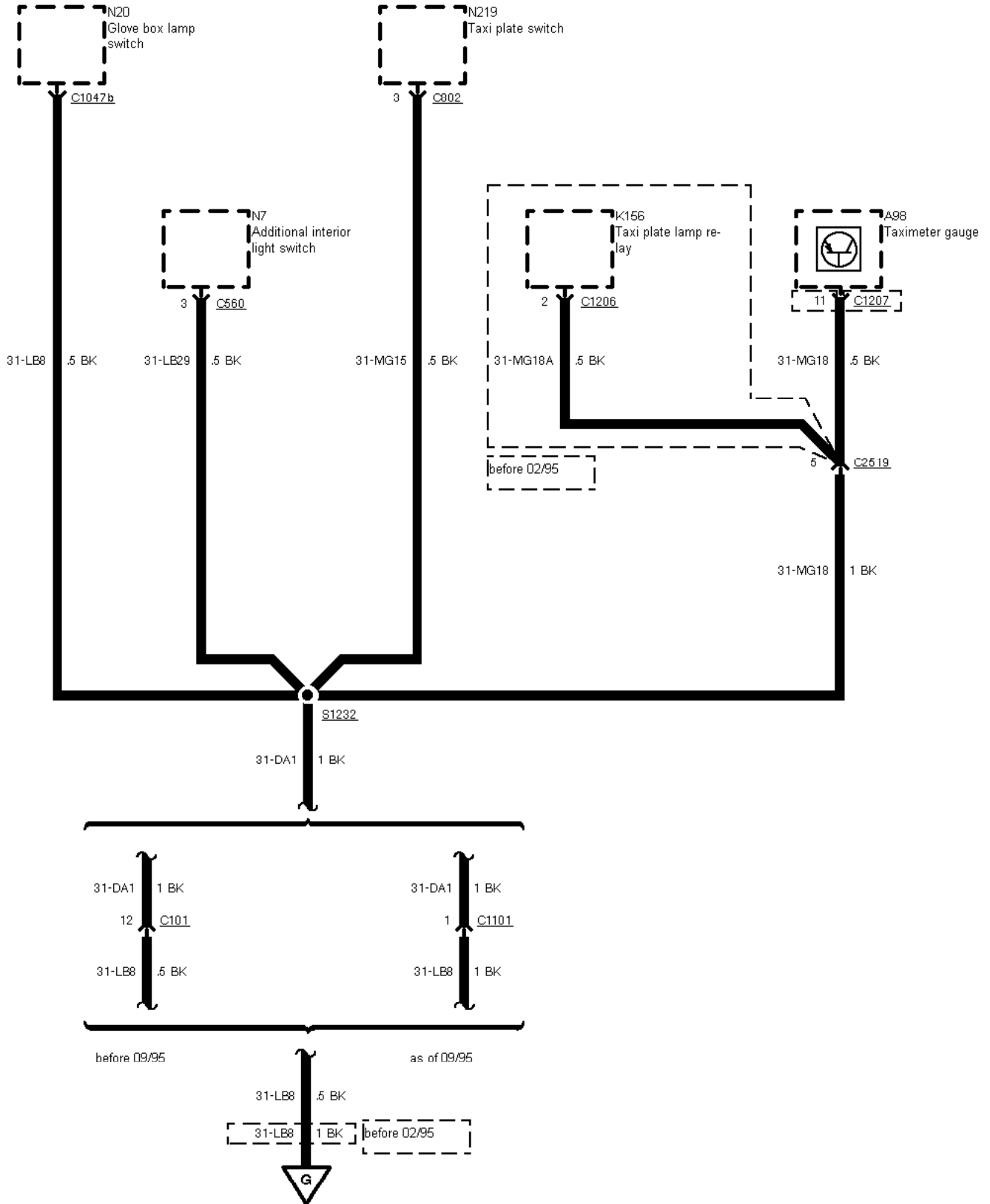

01-04-15 as of 09/95

01-04-17 before 09/95

01-04-014 , Ground Distribution , Ground G1 except taxi as of 09/95

RHD

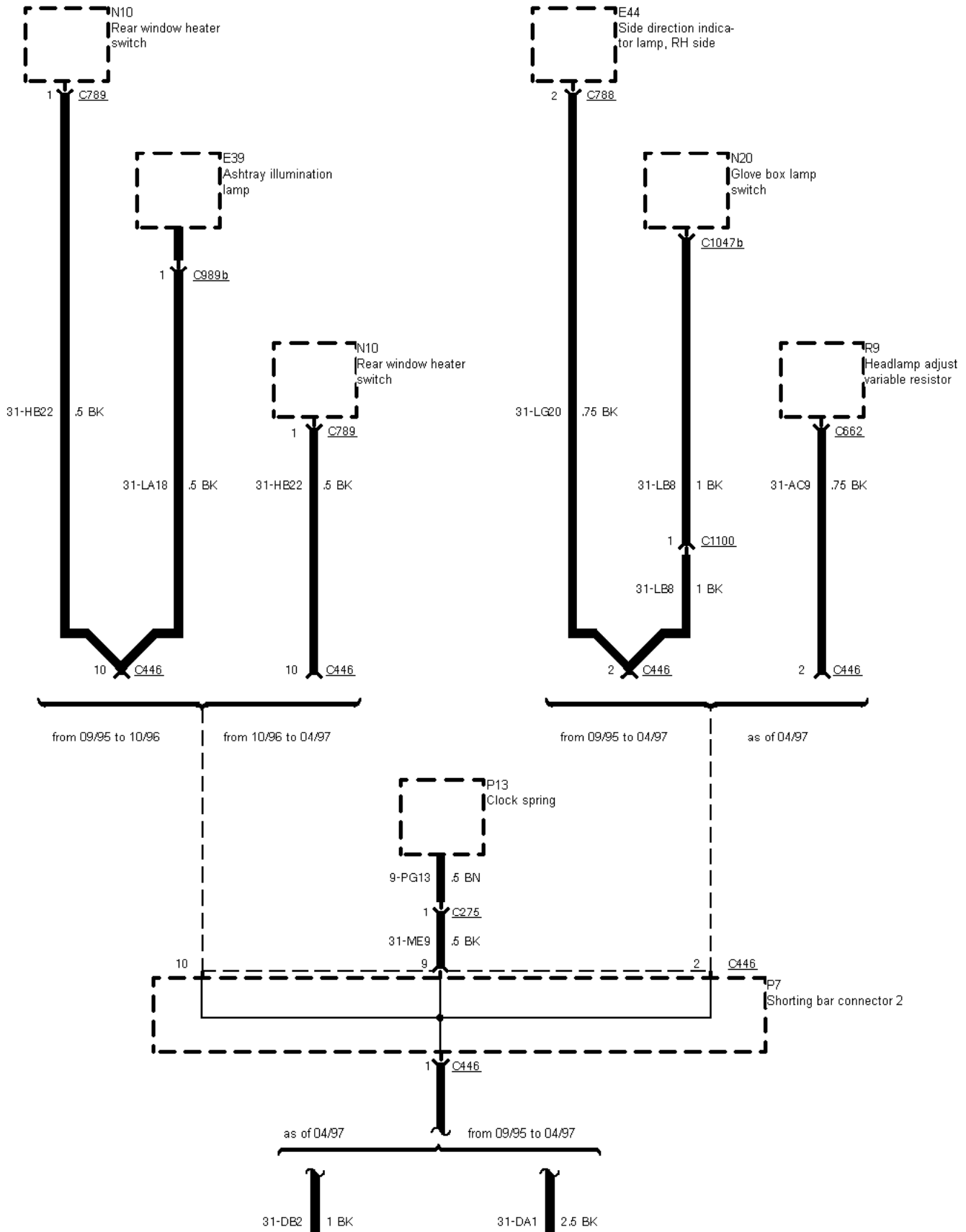



01-04-18



01-04-19

01-04-015 , Ground Distribution , Ground G1 Taxi as of 09/95

RHD

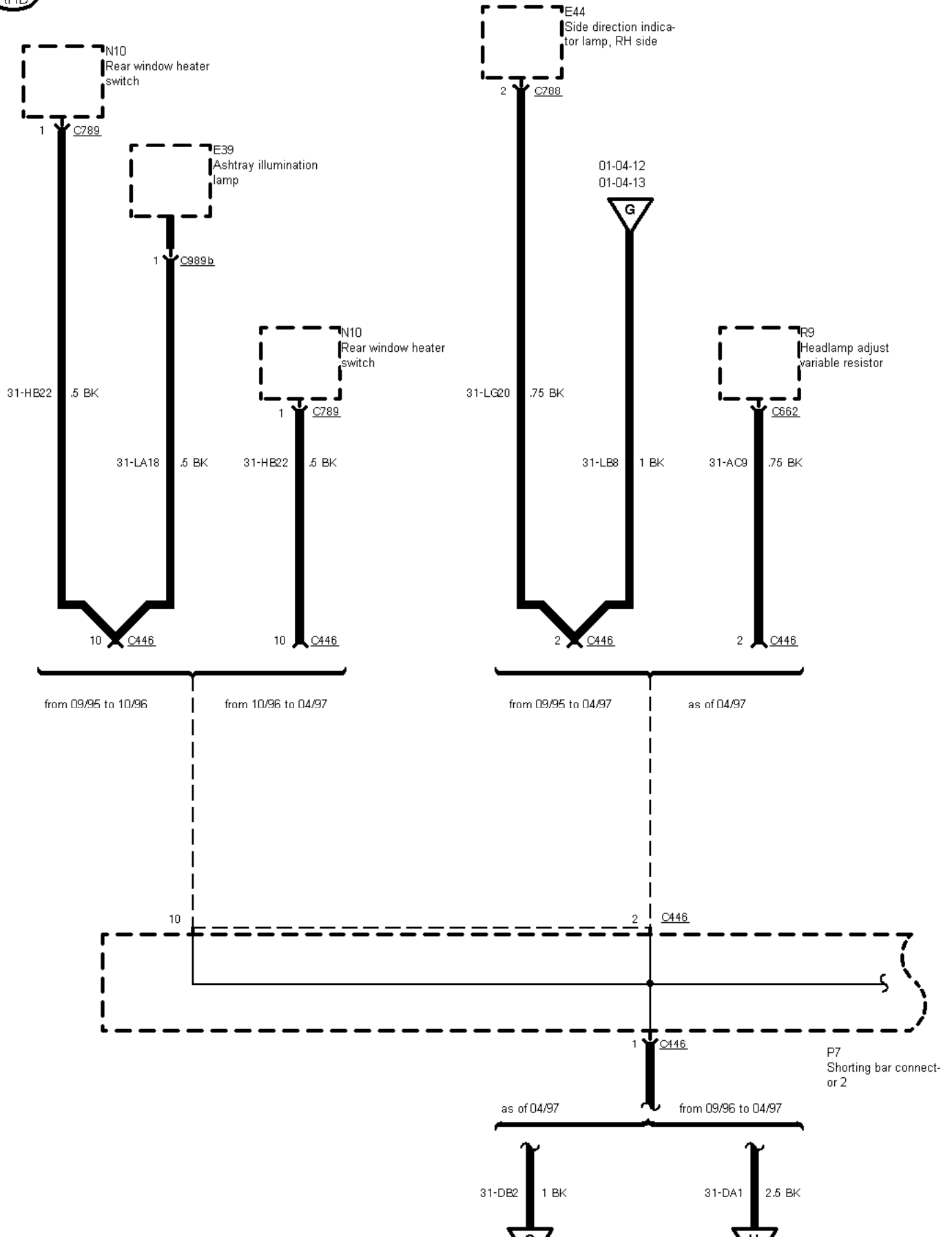

01-04-18

01-04-19

01-04-016 , Ground Distribution , Ground G1 Taxi as of 09/95

RHD

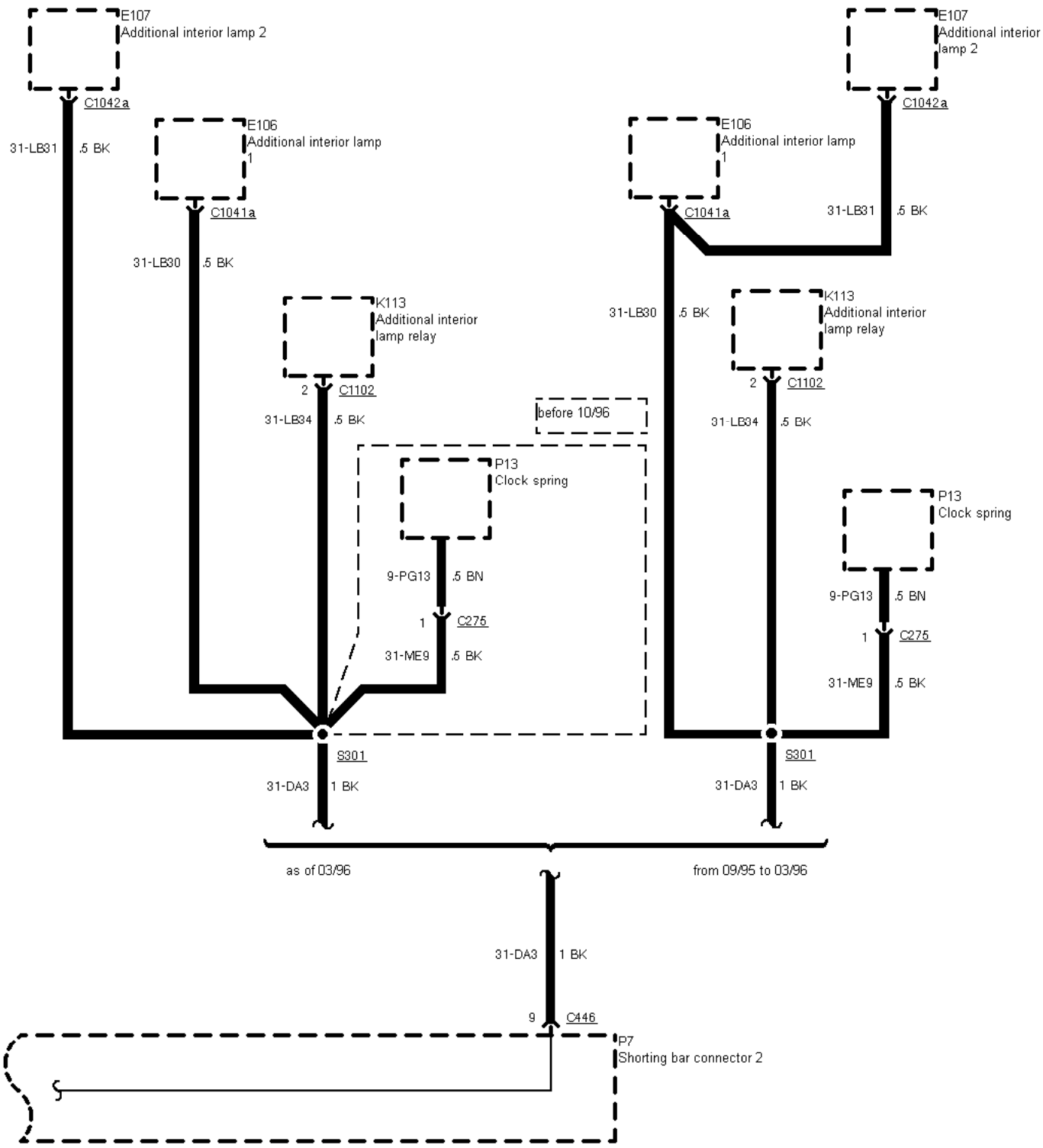

01-04-017 , Ground Distribution , Ground G1 before 09/95

RHD

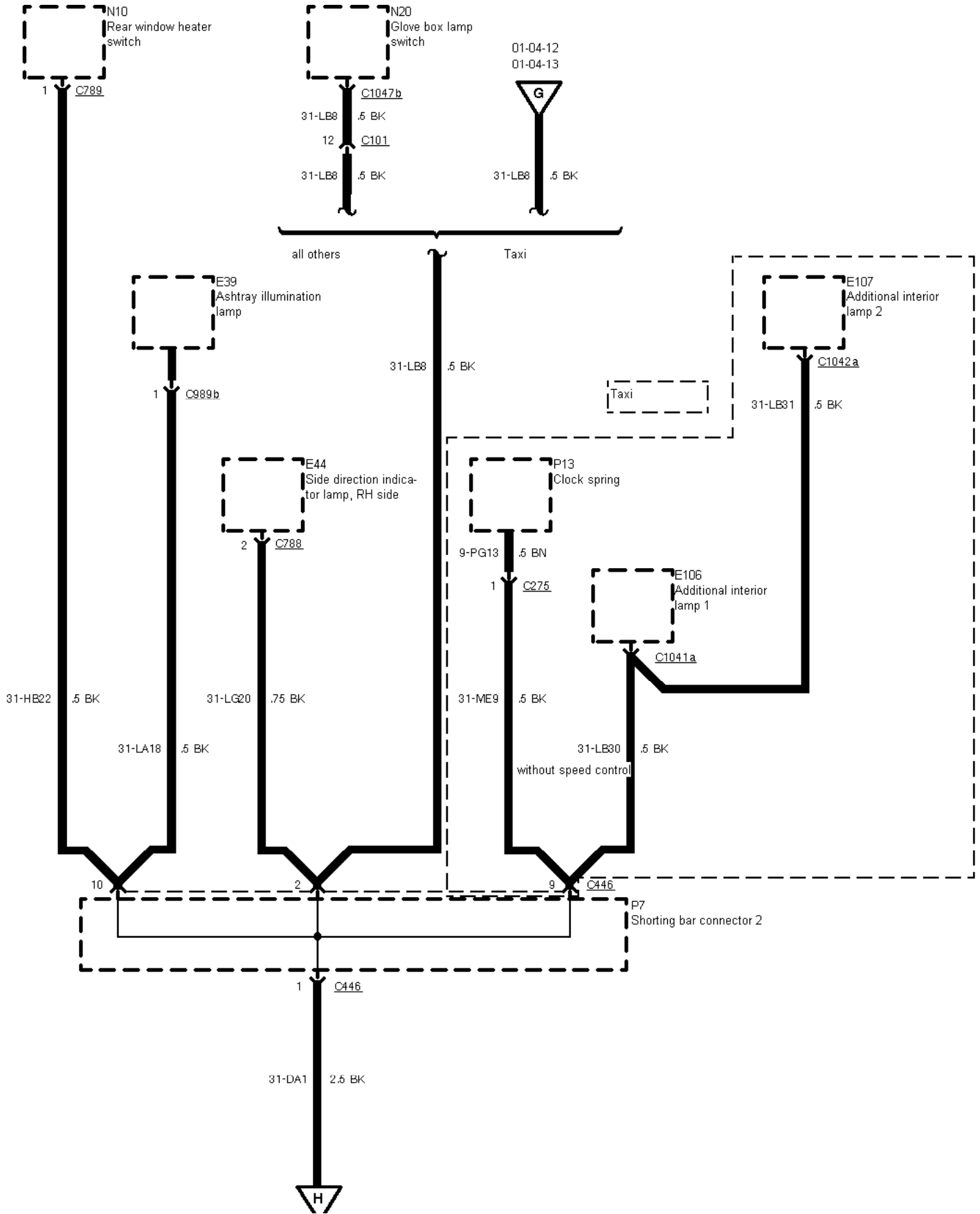

01-04-018 , Ground Distribution , Ground G1 as of 04/97

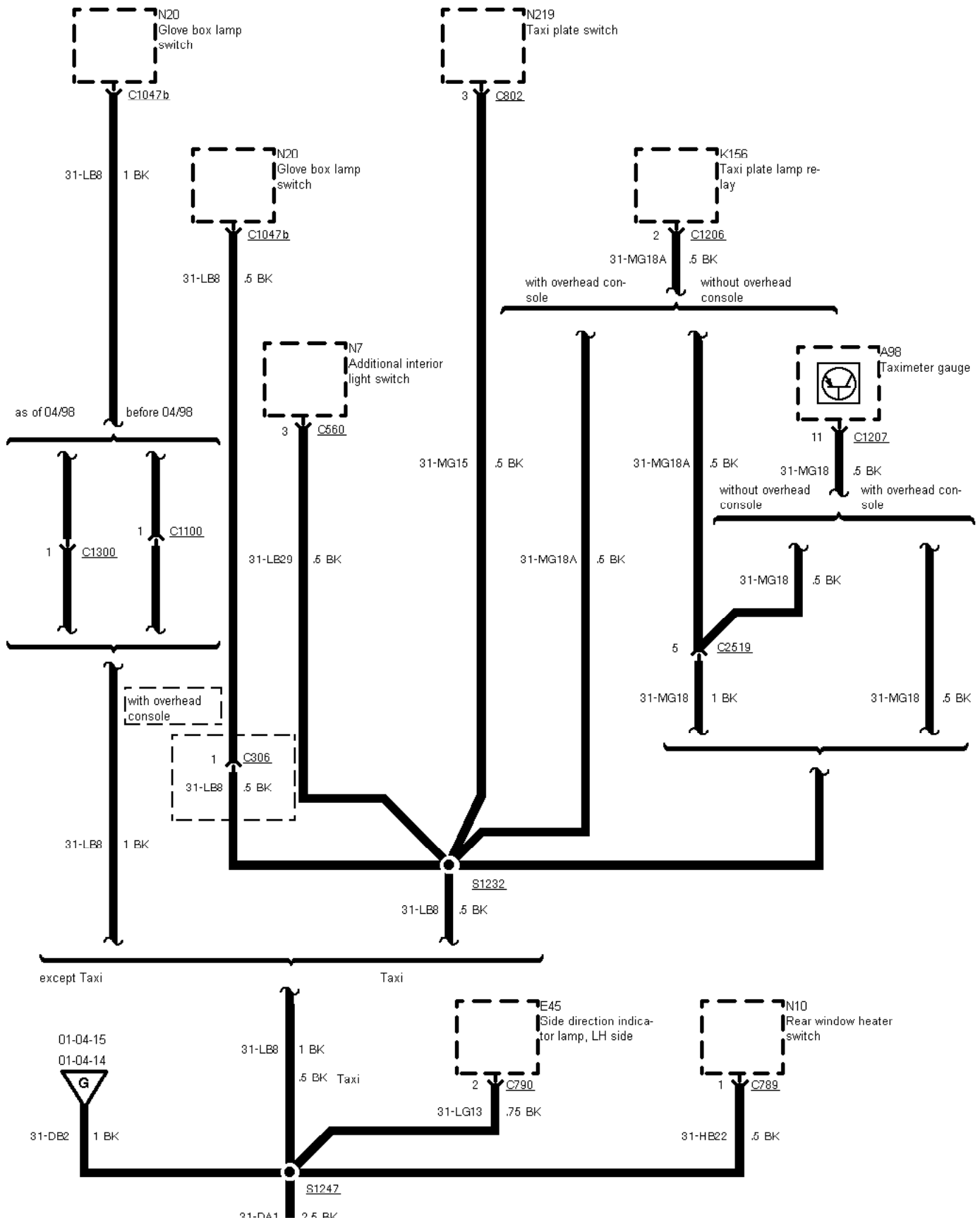

01-04-19



01-04-19

01-04-019 , Ground Distribution , Ground G1

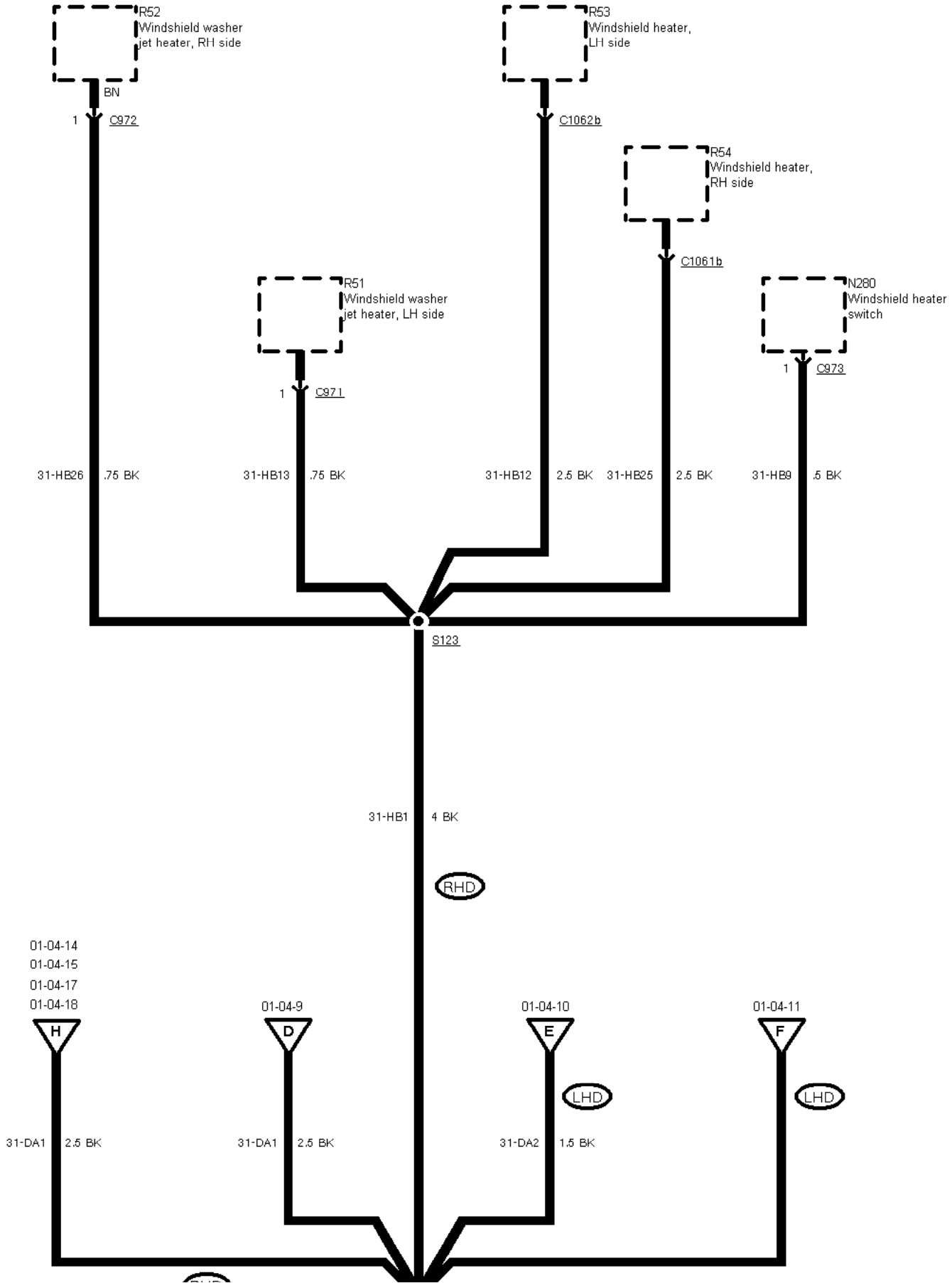



01-04-020 , Ground Distribution , Ground G2

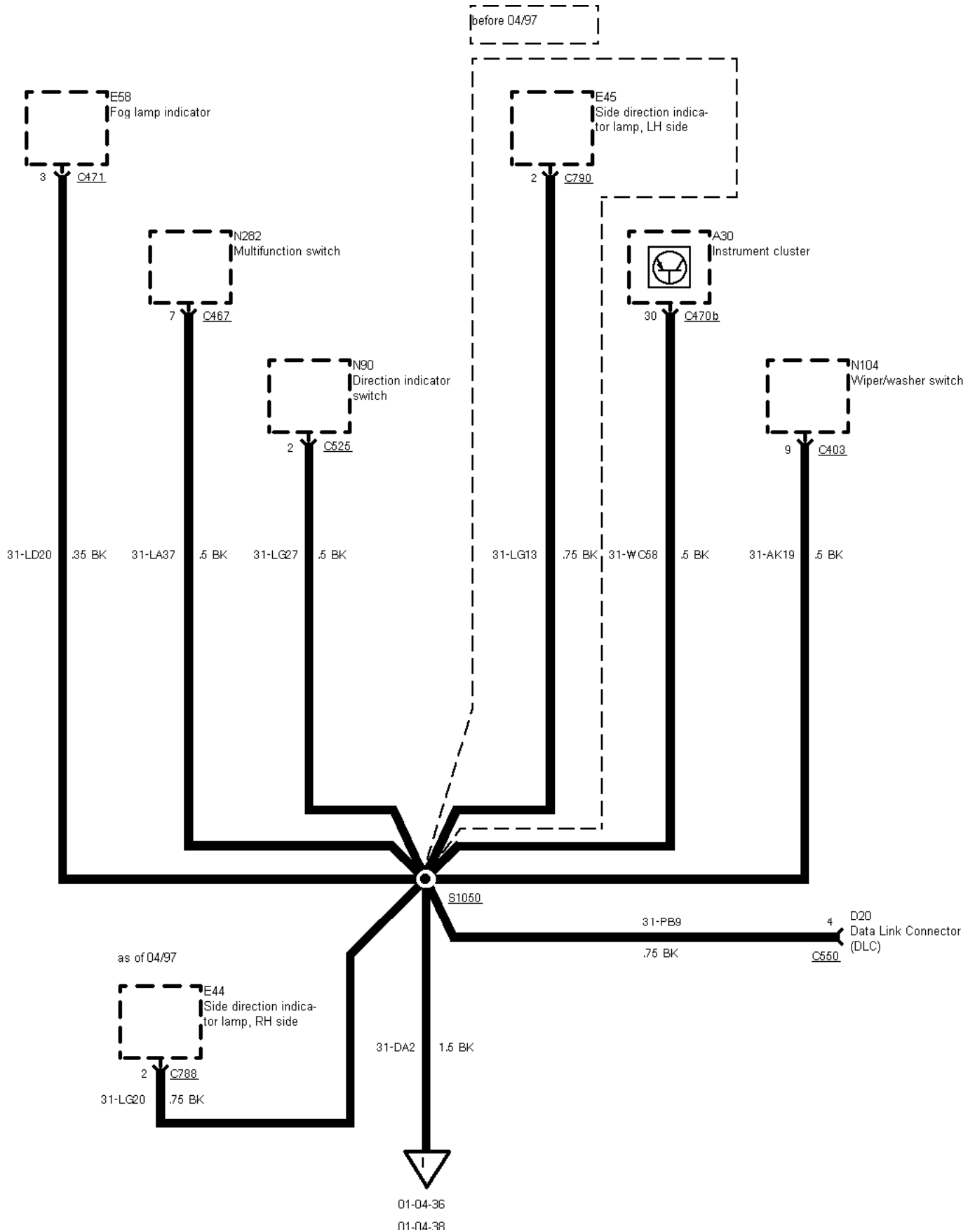

01-04-021 , Ground Distribution , Ground G2 Left-hand-drive vehicles, low series version before 03/96

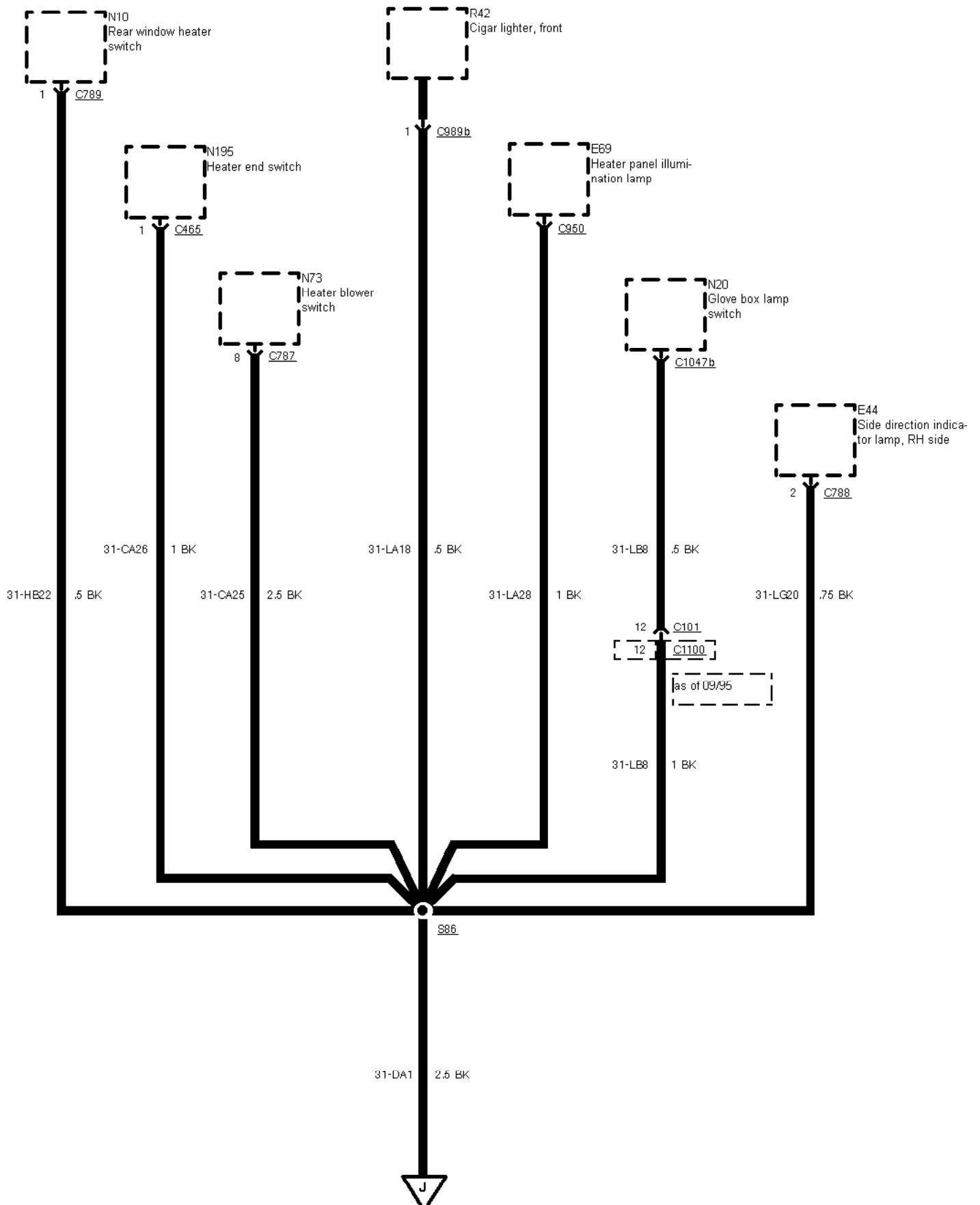

▼
01-04-36
01-04-38

01-04-022 , Ground Distribution , Ground G2

LHD

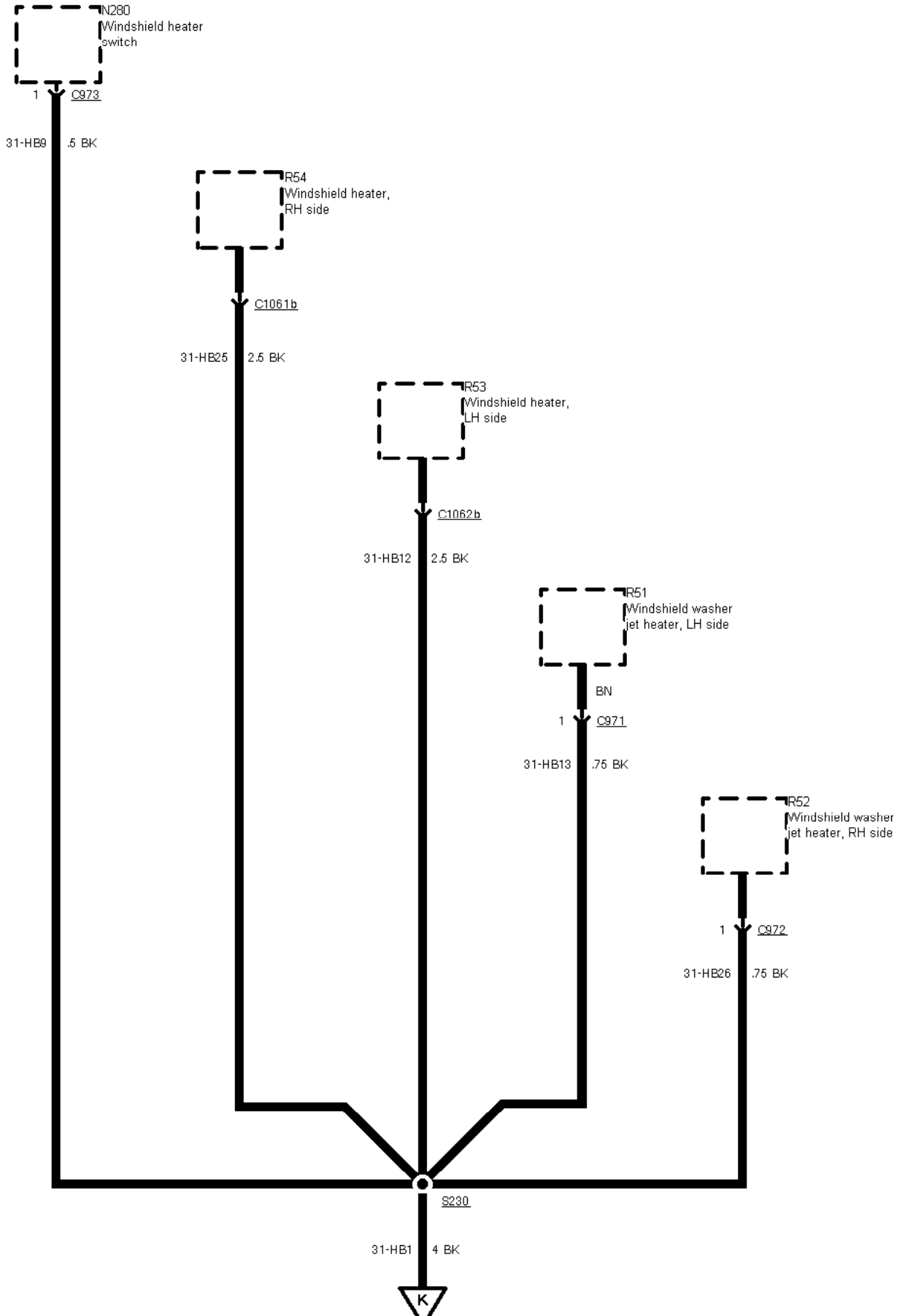



01-04-36

01-04-38

01-04-023 , Ground Distribution , Ground G2

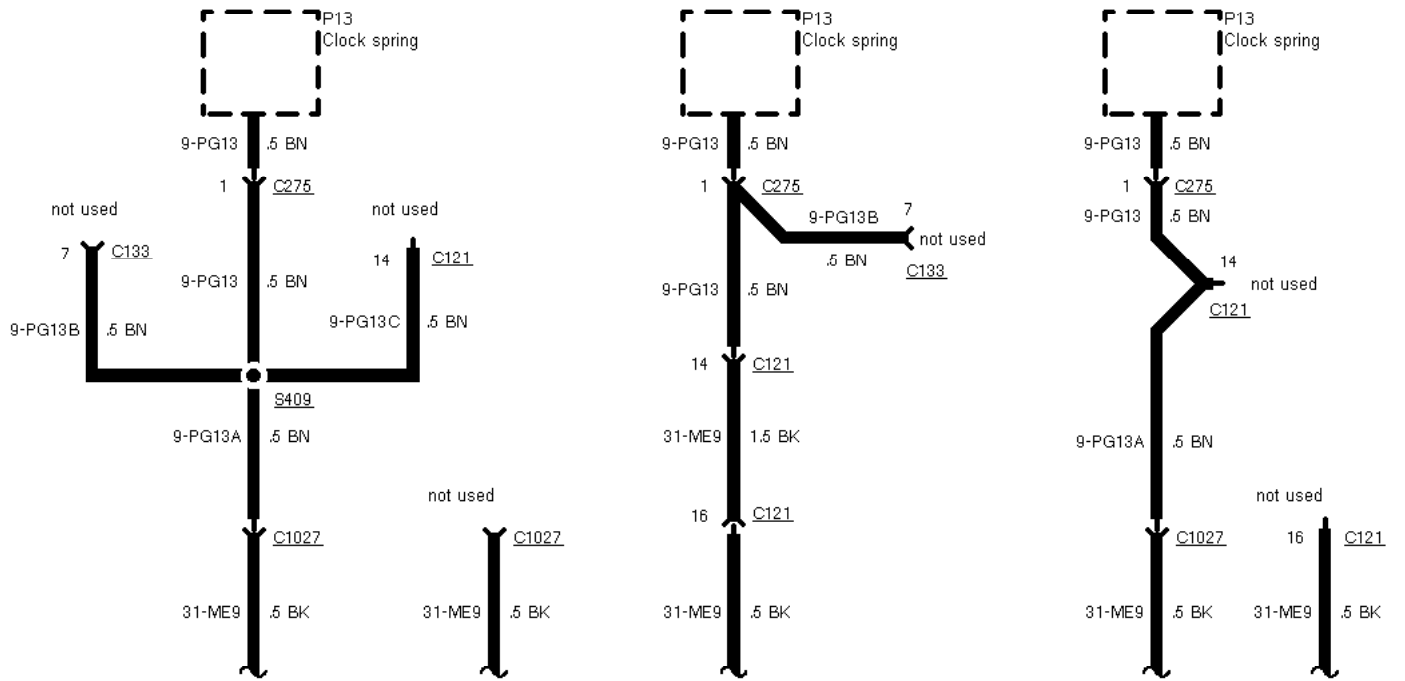

without speed control from 03/96 to 04/98

with speed control before 04/98

without speed control as of 04/98

without speed control before 03/96

with speed control as of 04/98

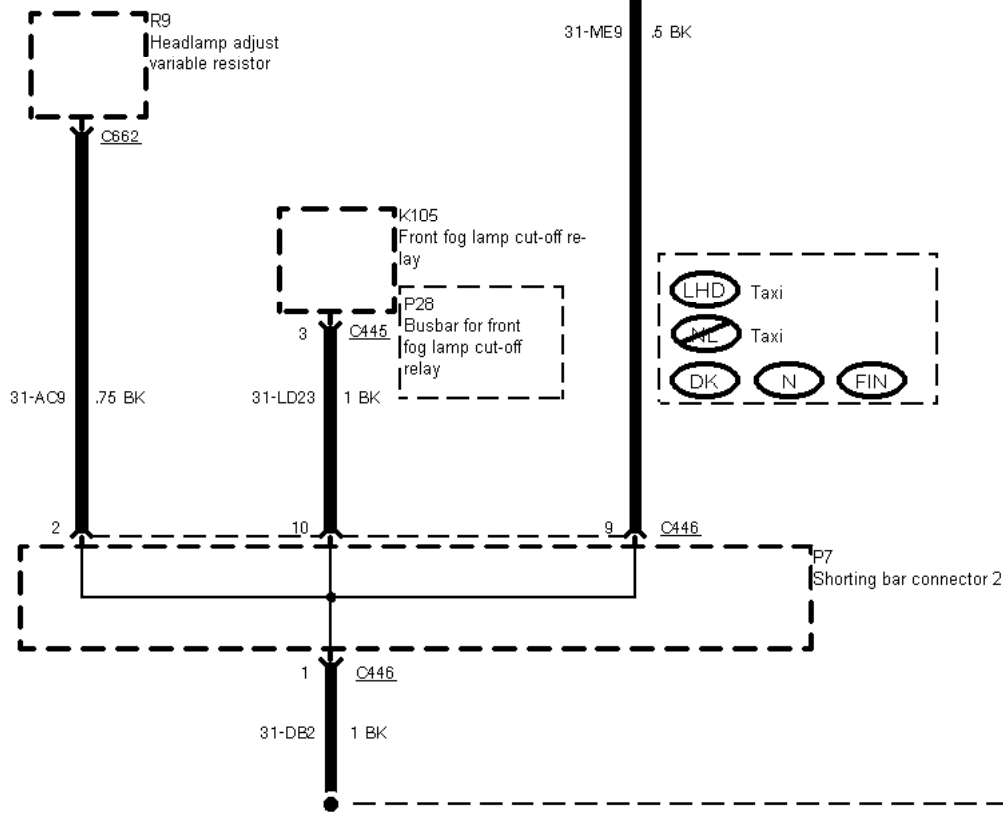

58b (partial)

01-04-024 , Ground Distribution , Ground G2

LHD except low series version before 03/96, except taxi

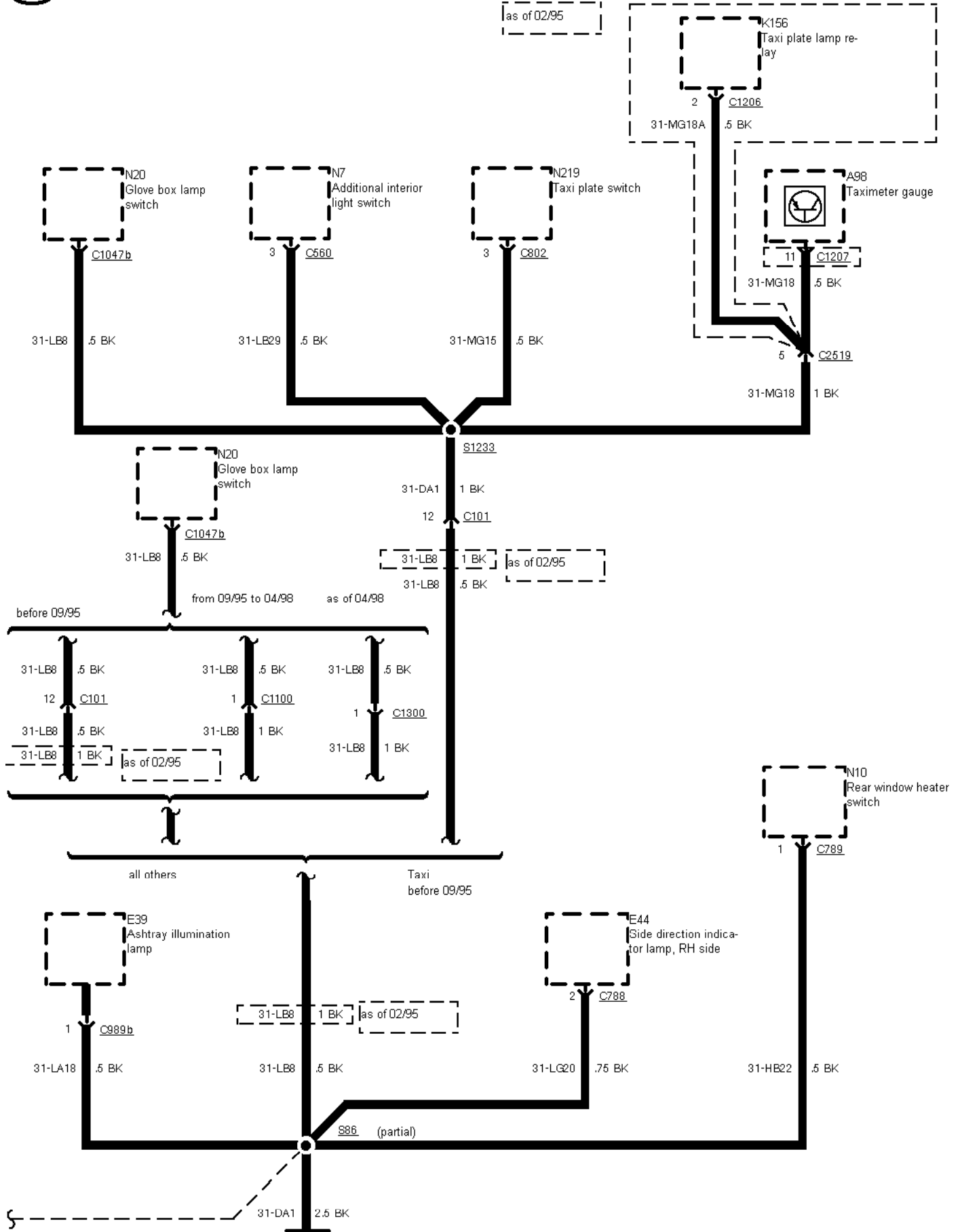



01-04-36
01-04-36

01-04-025 , Ground Distribution , Ground G2

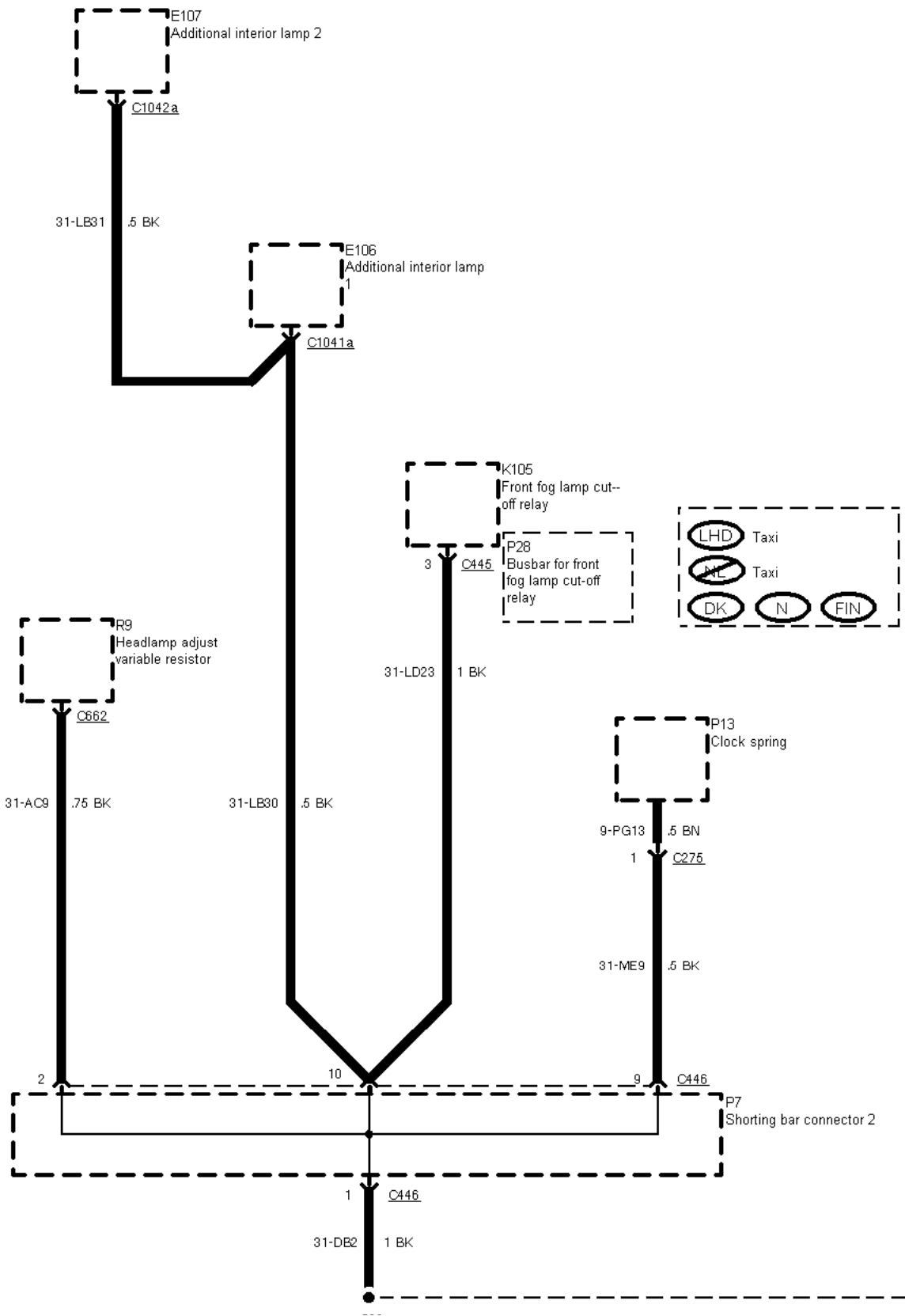

01-04-026 , Ground Distribution , Ground G2

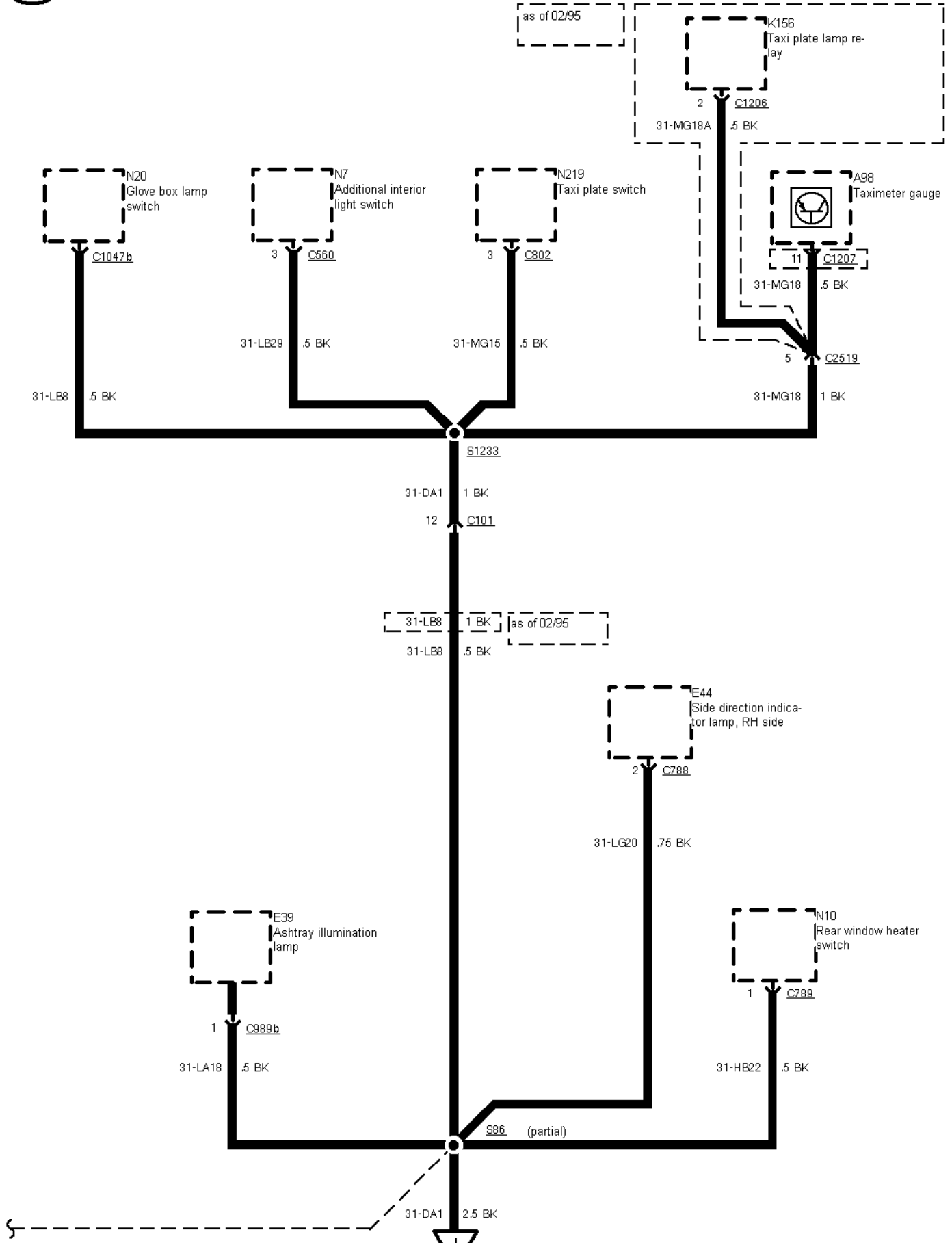



01-04-36
01-04-36

01-04-027 , Ground Distribution , Ground G2

LHD Taxi, as of 09/95 without overhead console

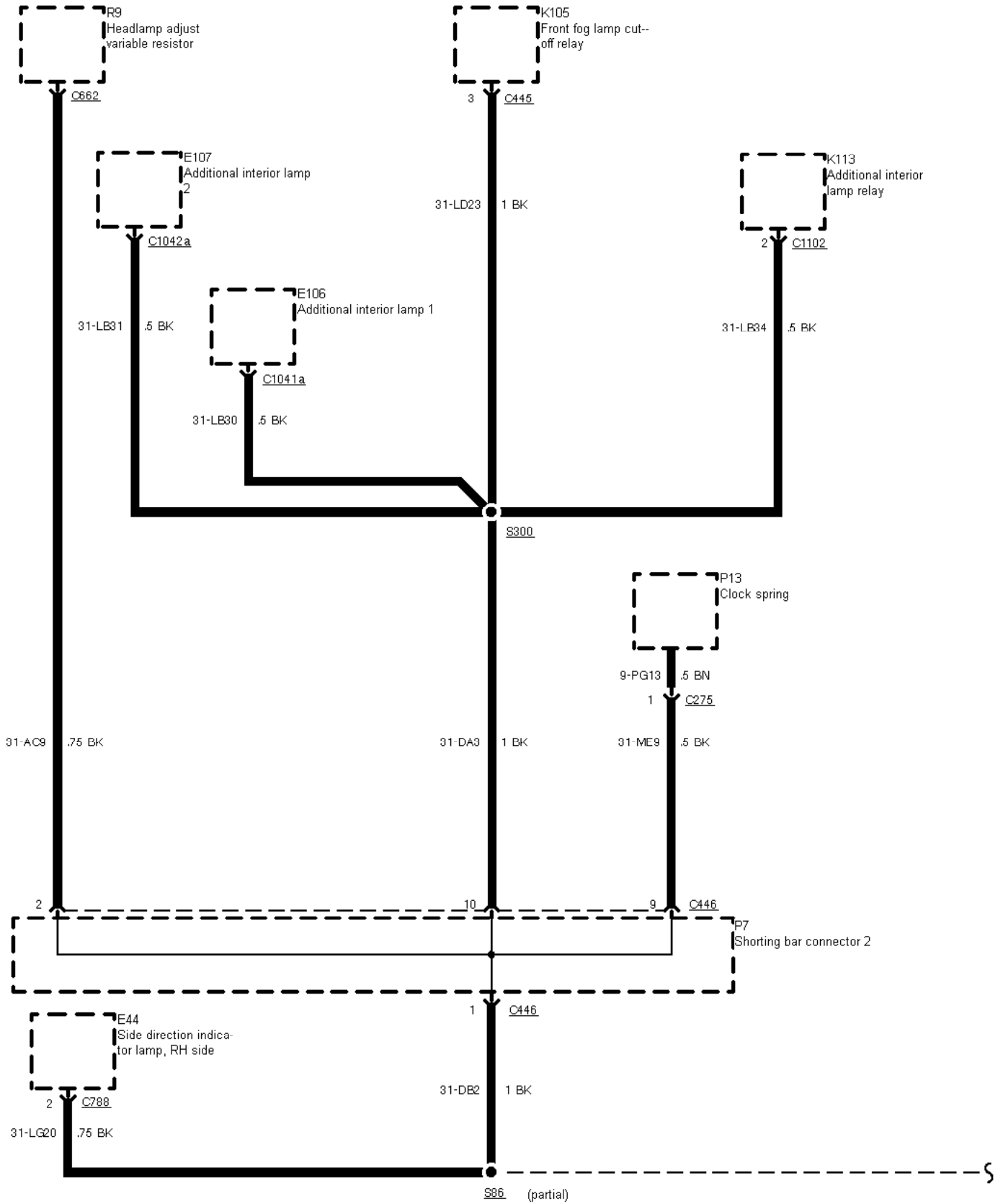

01-04-028 , Ground Distribution , Ground G2



Taxi, as of 09/95 without overhead console

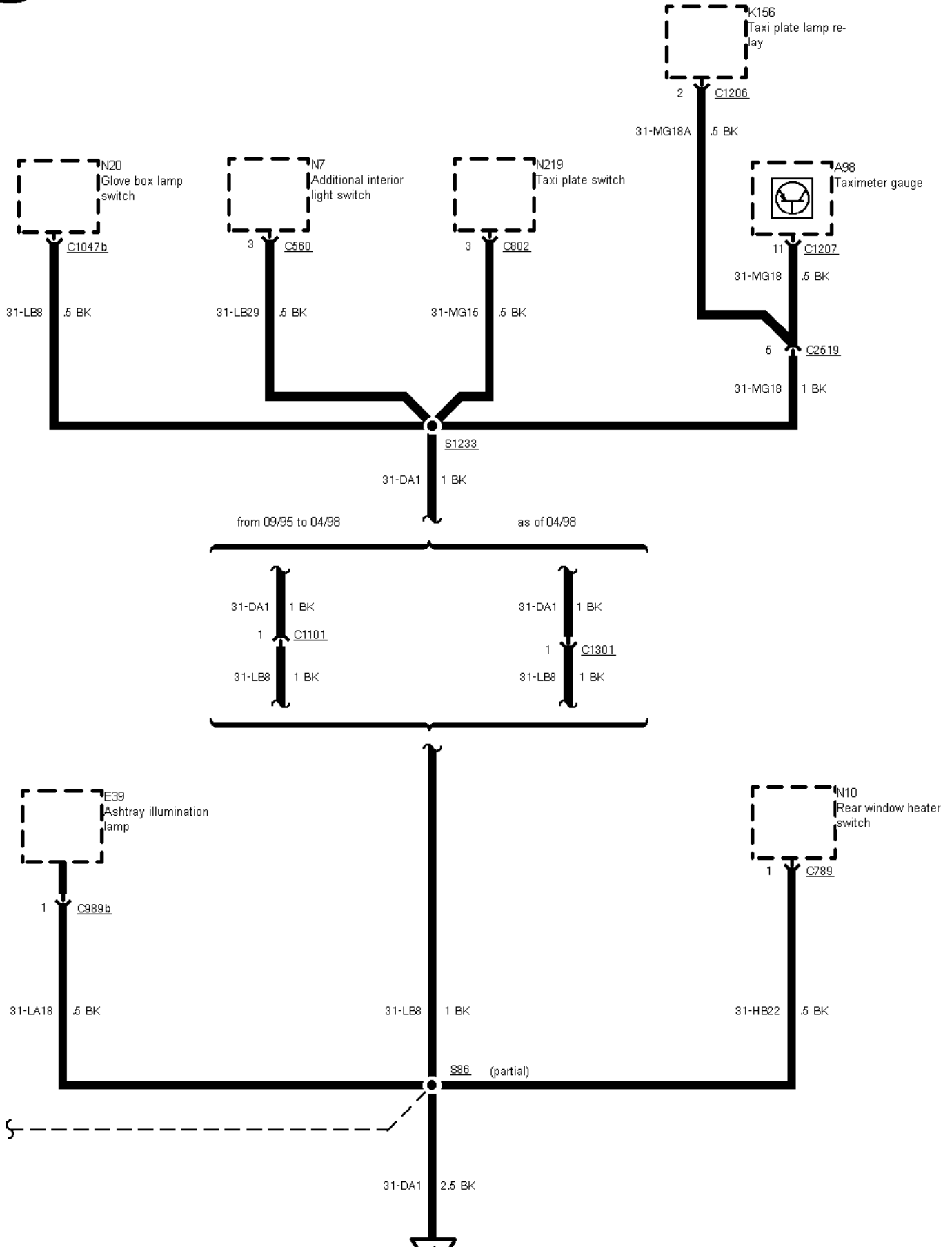



01-04-36

01-04-38

01-04-029 , Ground Distribution , Ground G2

LHD Taxi, as of 09/95 with overhead console

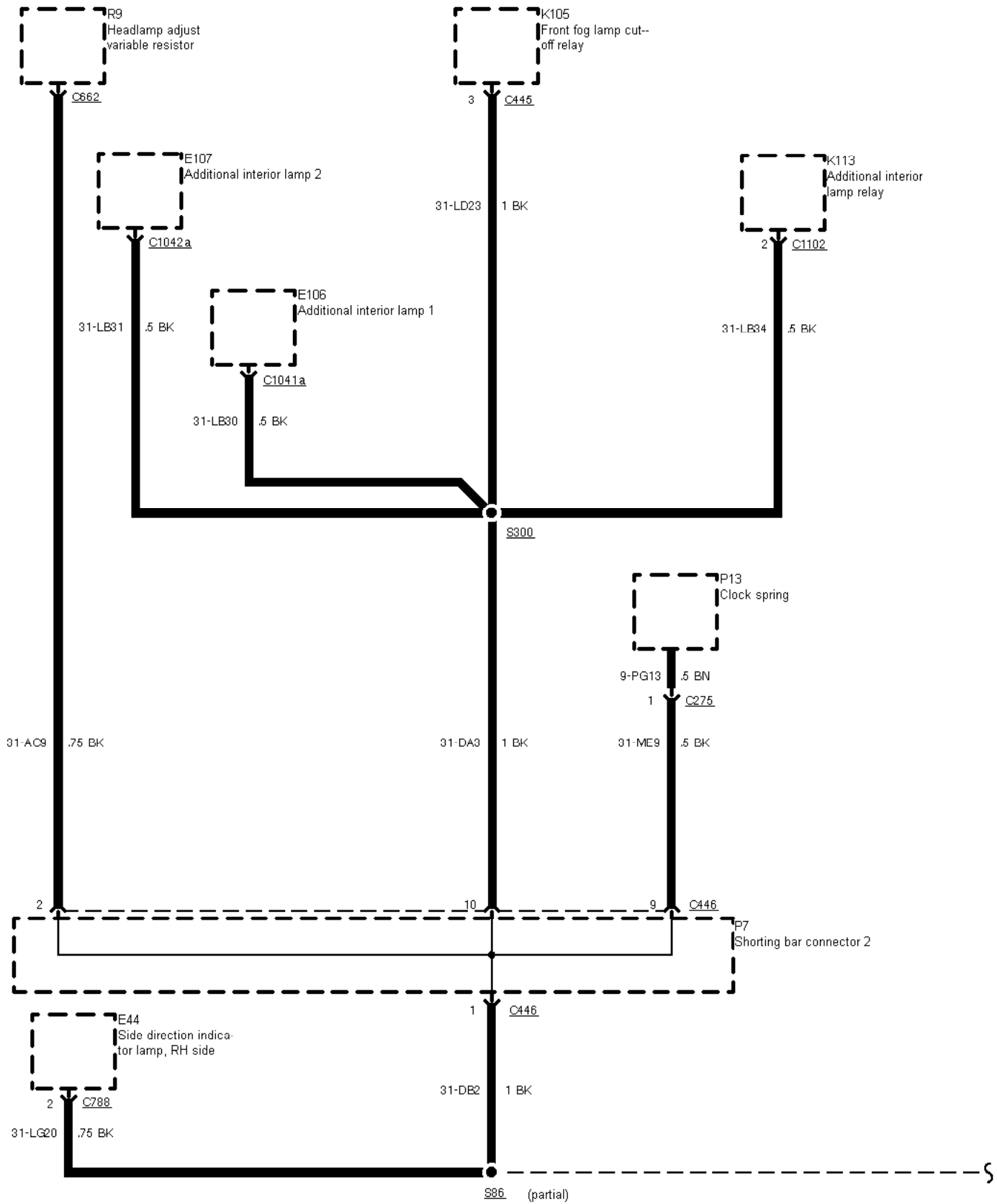

01-04-030 , Ground Distribution , Ground G2

Taxi, as of 09/95 with overhead console

LHD

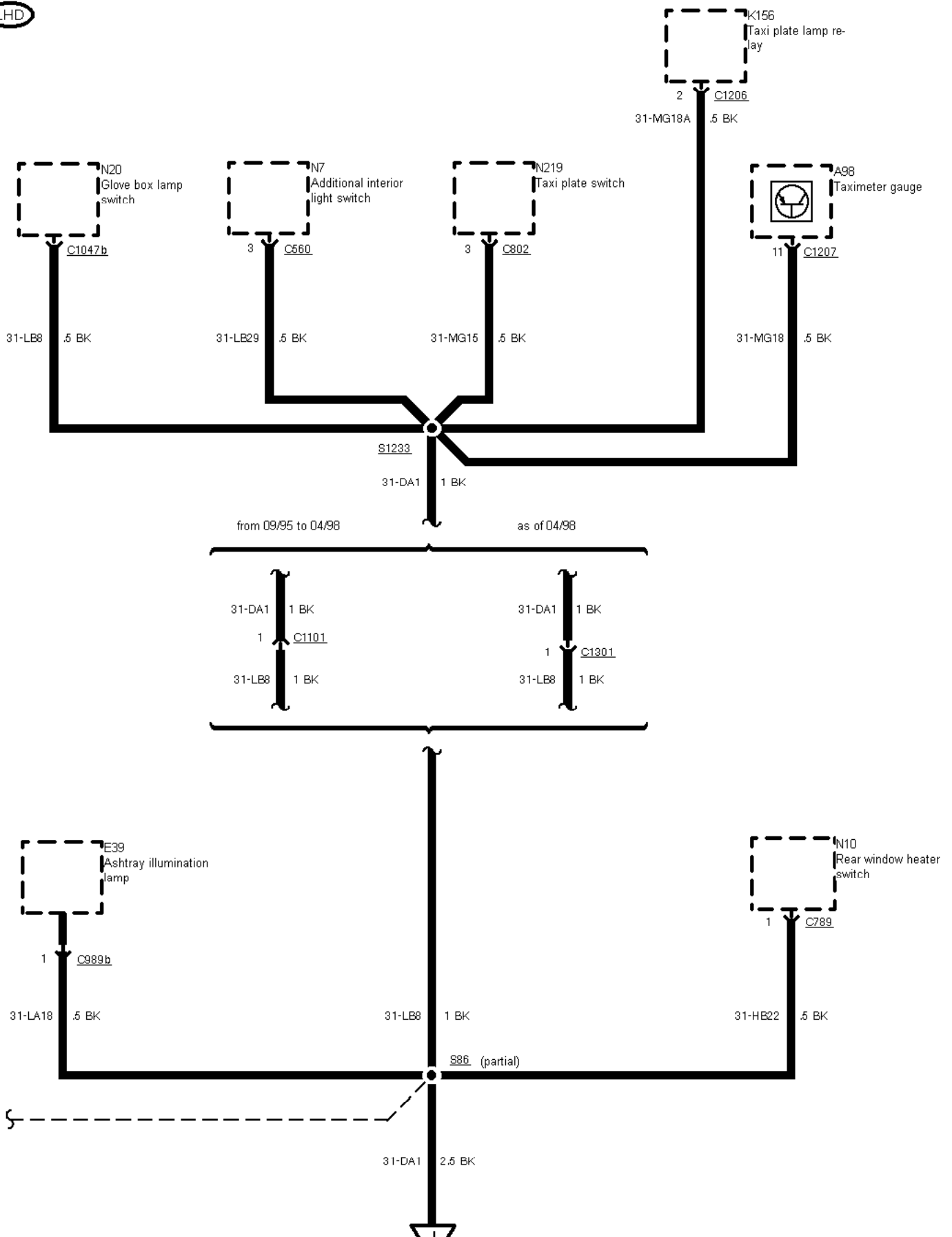



01-04-36
01-04-36

01-04-031 , Ground Distribution , Ground G2 Notchback

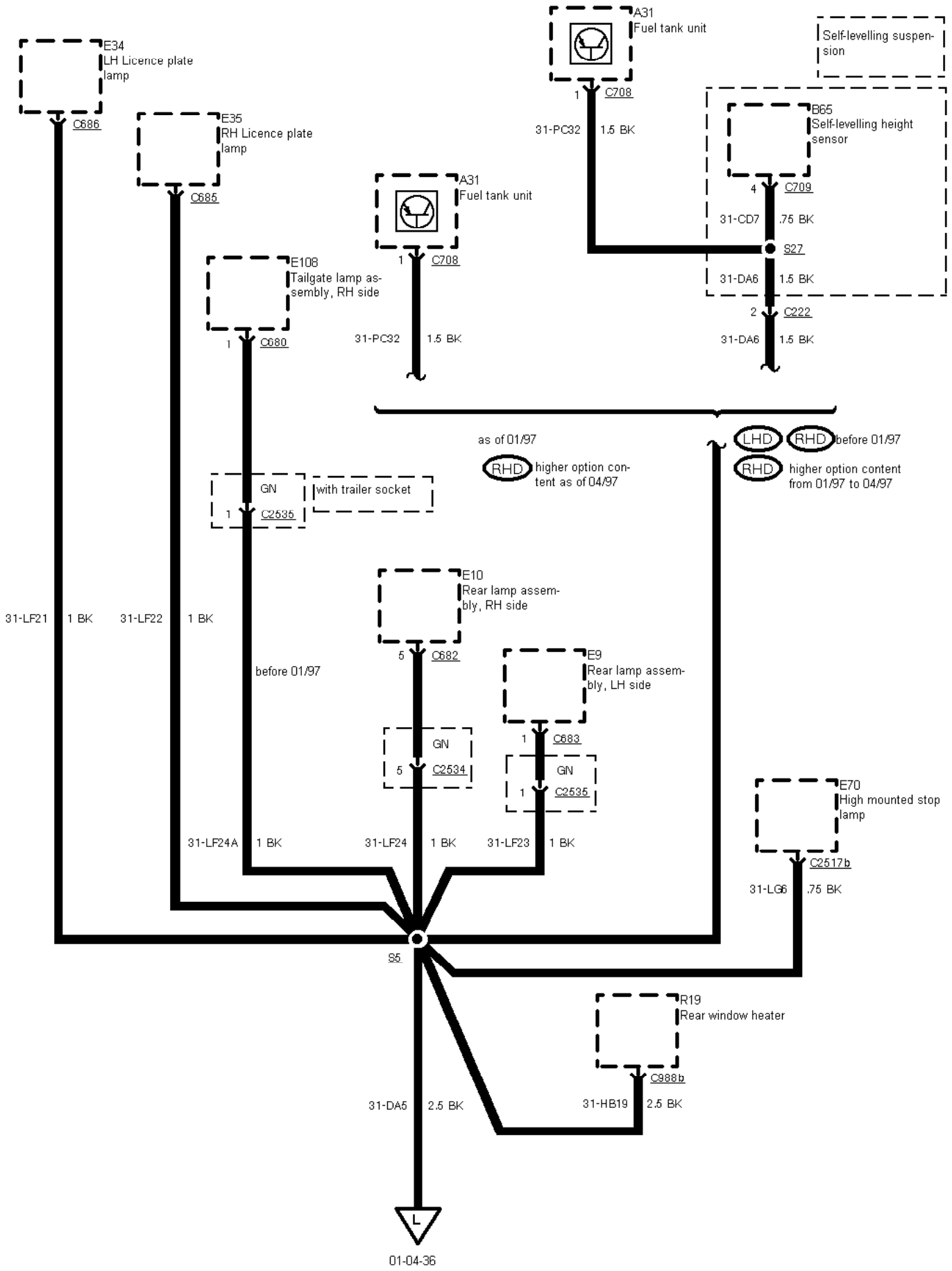

01-04-032 , Ground Distribution , Ground G2 Wagon

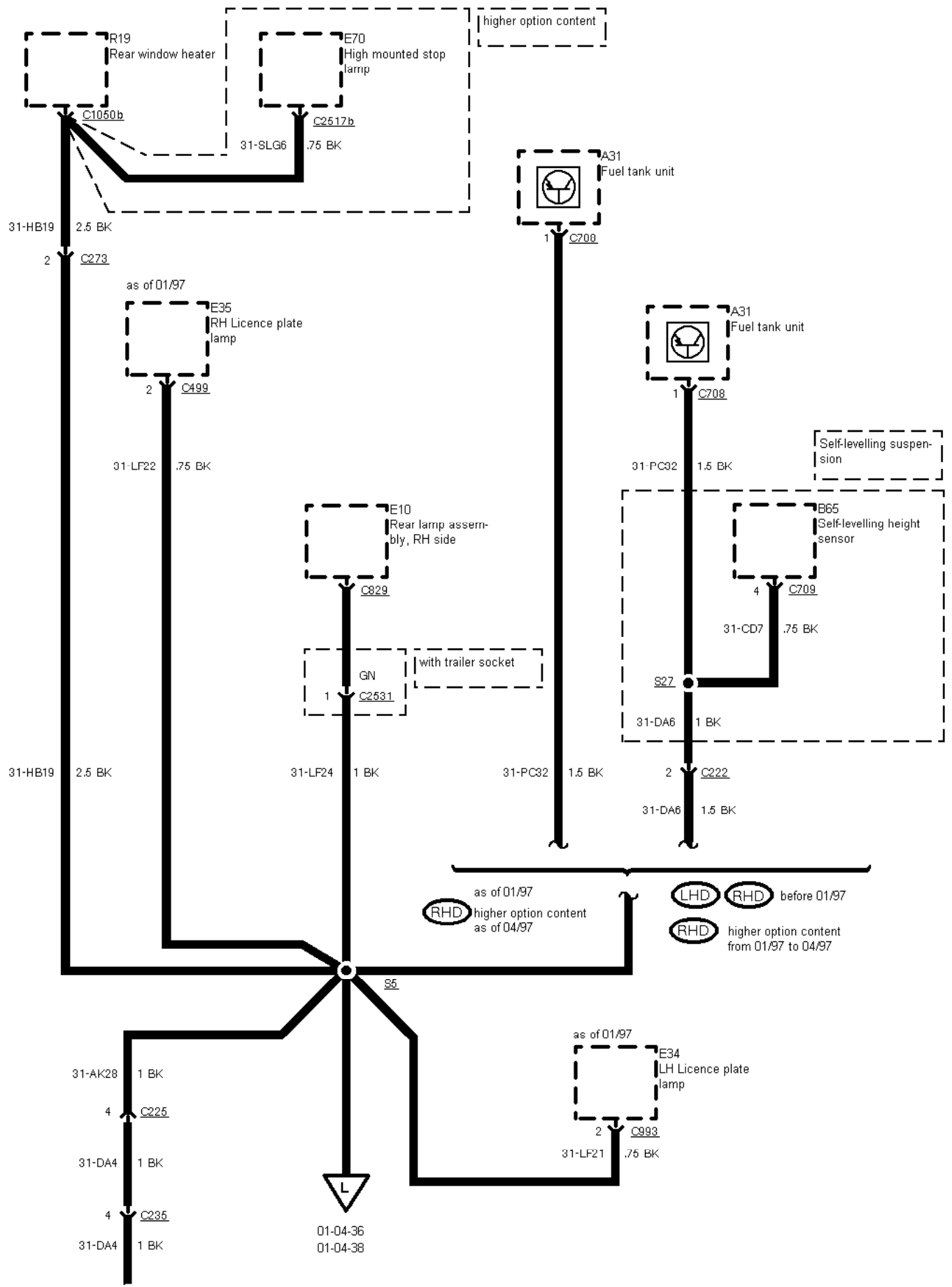

S118
01-04
G2

01-04-033 , Ground Distribution , Ground G2

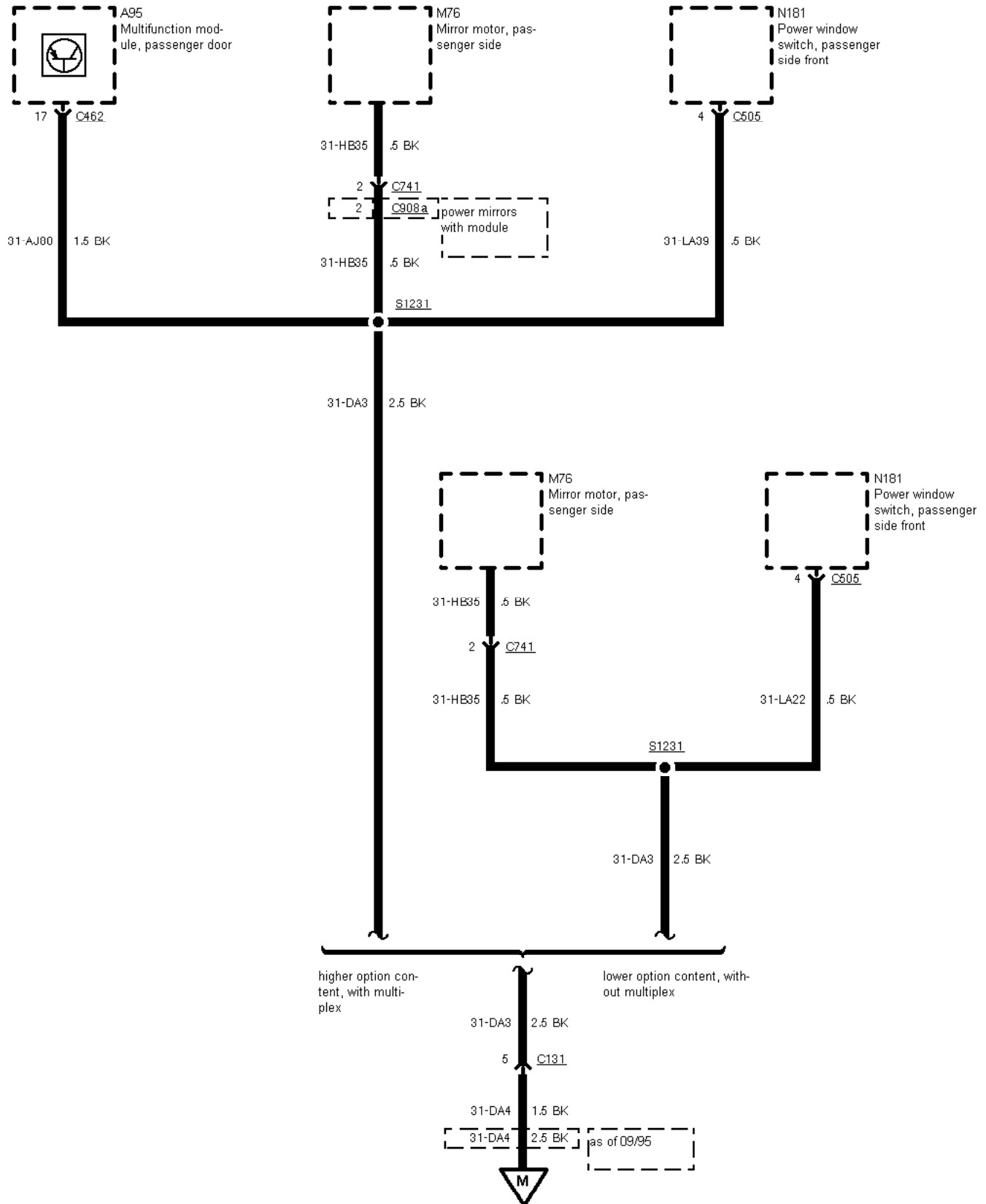

01-04-36
01-04-38

01-04-034 , Ground Distribution , Ground G2

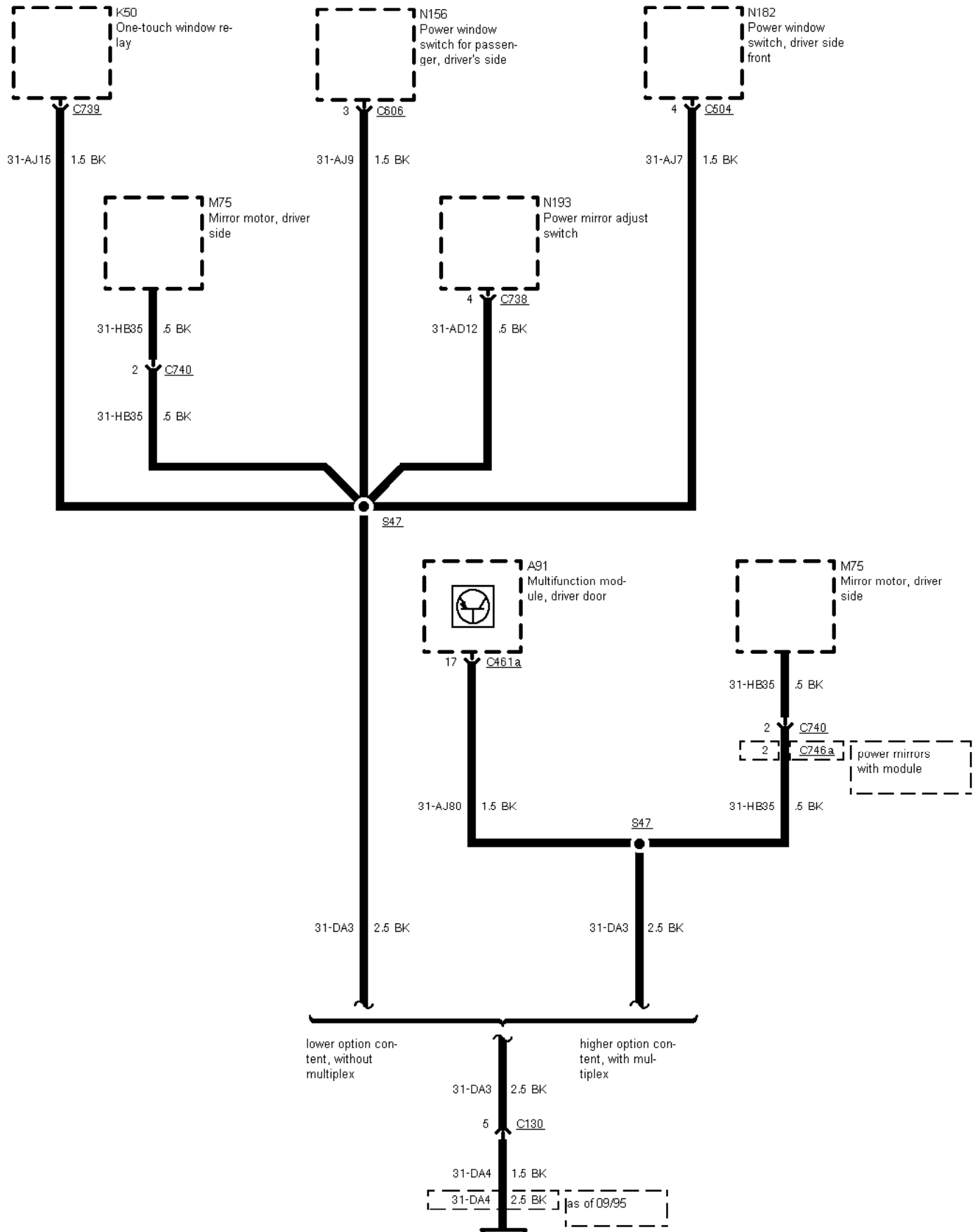



01-04-36
01-04-38

01-04-035 , Ground Distribution , Ground G2

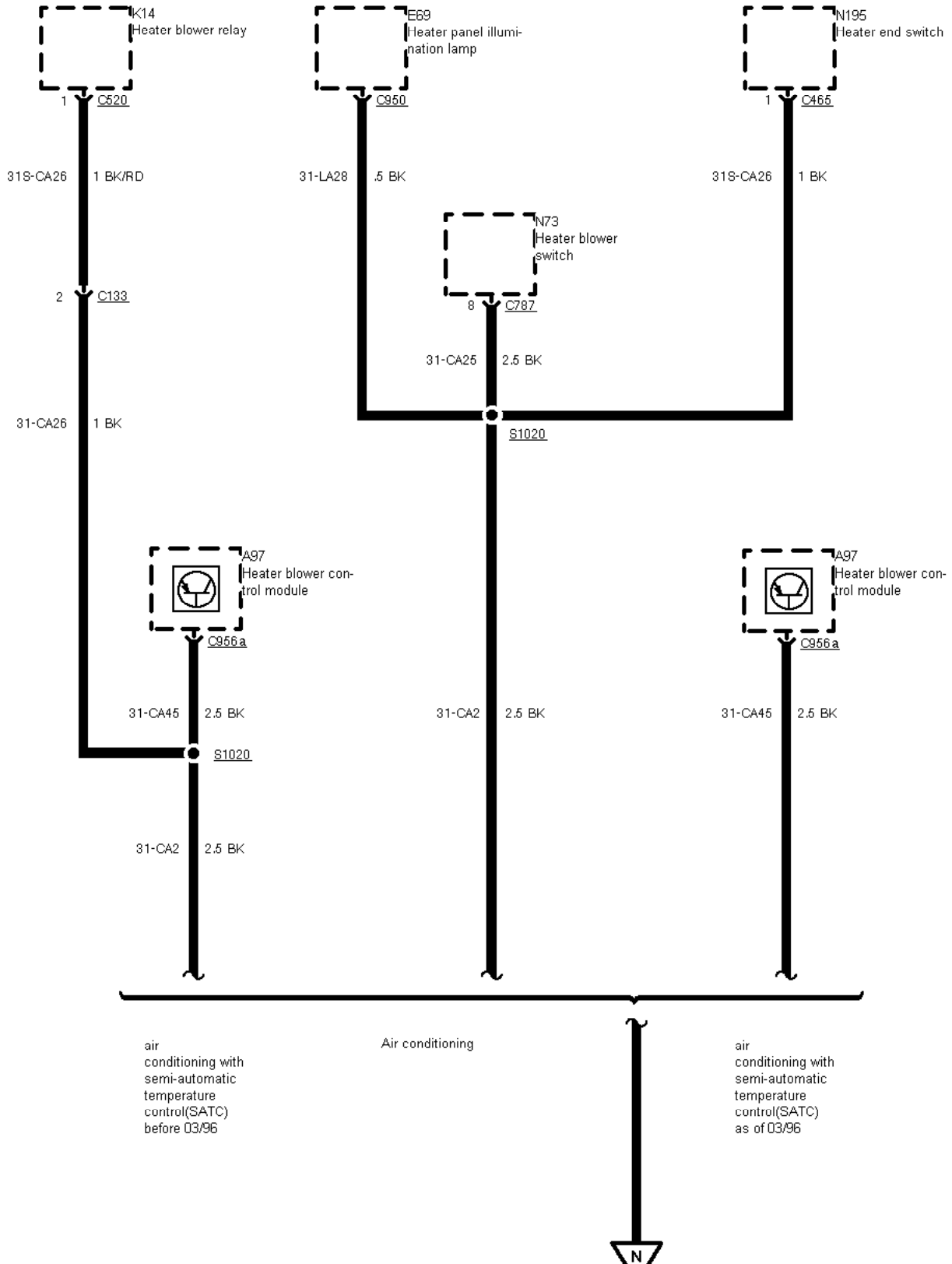



01-04-36

01-04-38

01-04-036 , Ground Distribution , Ground G2

Before 09/96

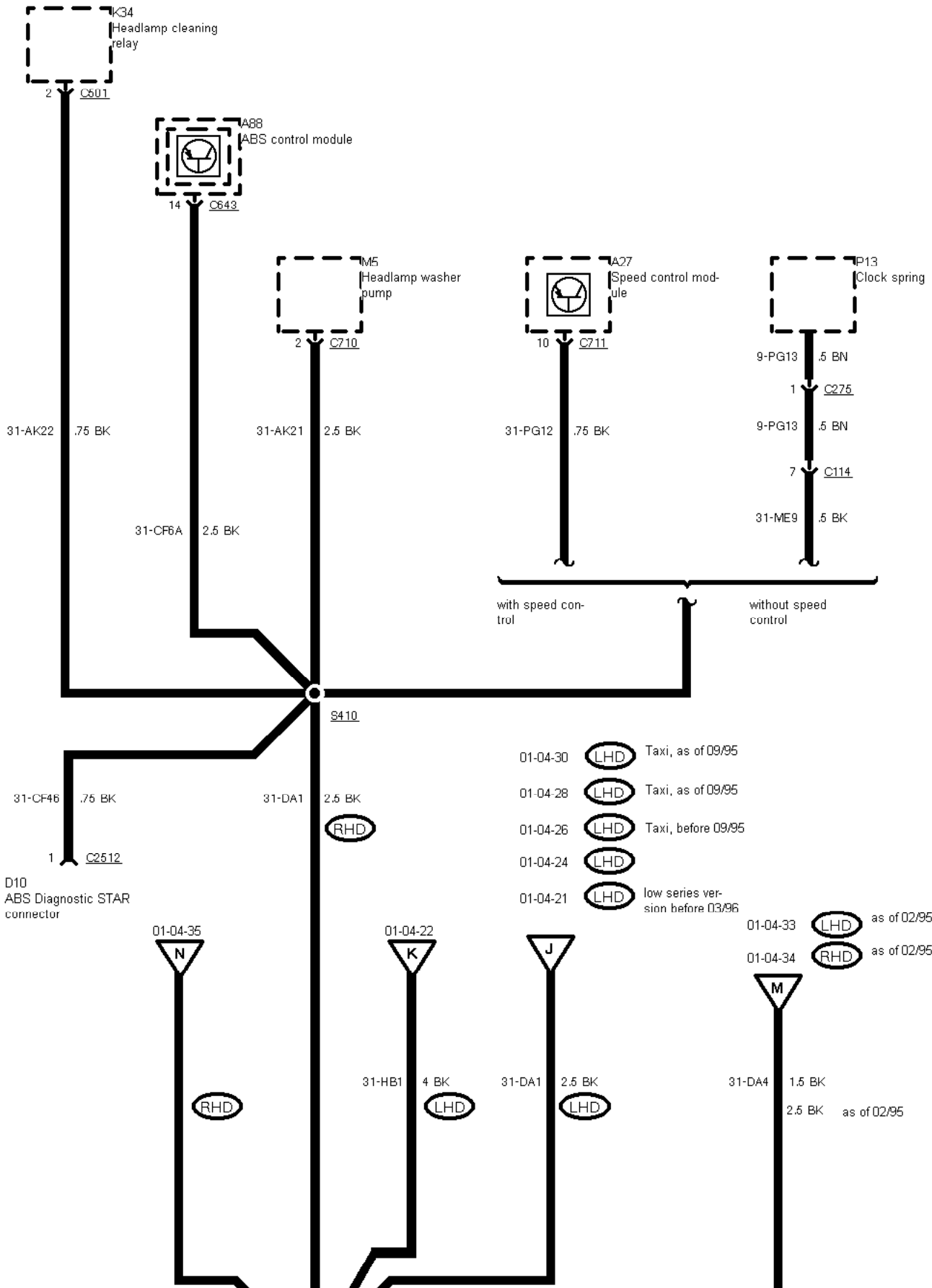



01-04-037 , Ground Distribution , Ground G2

ABS MK20-1

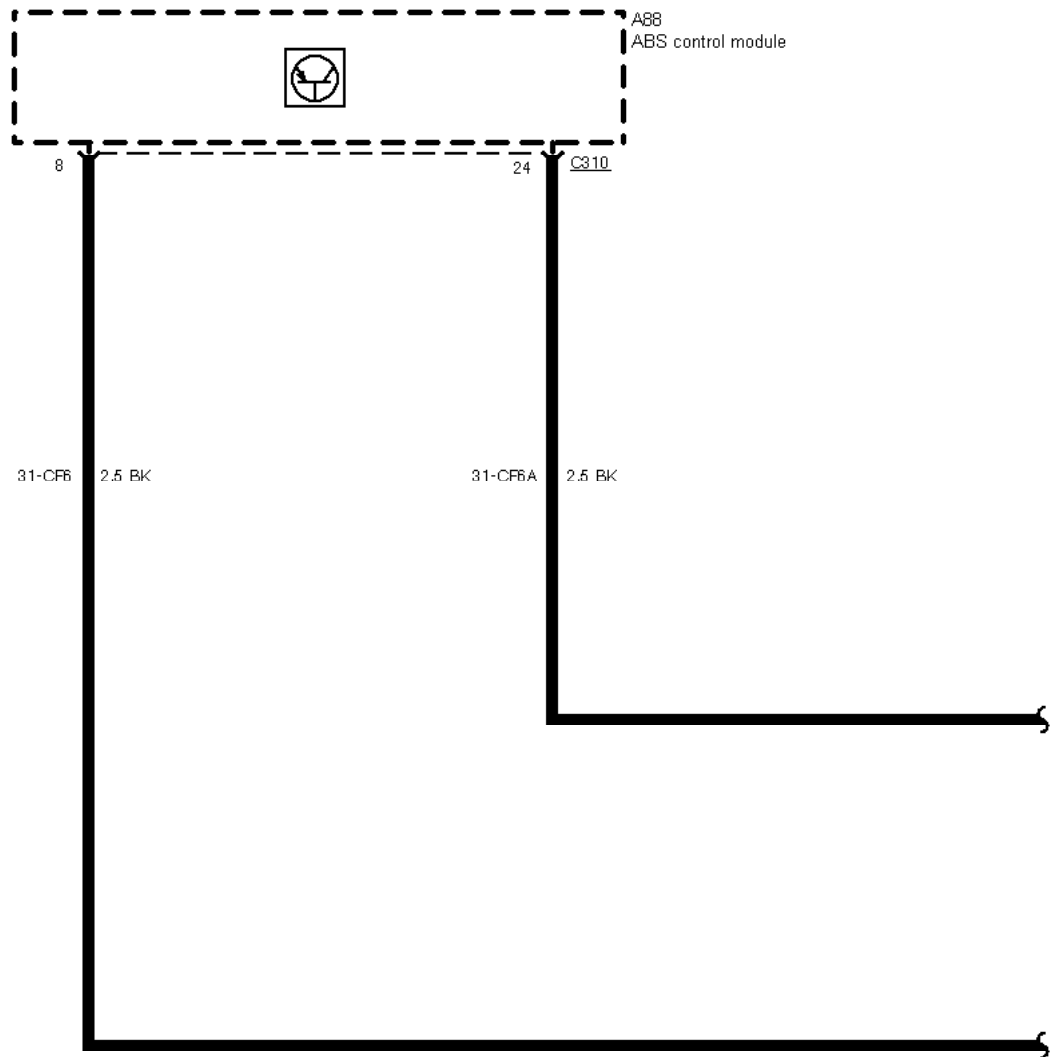

01-04-038 , Ground Distribution , Ground G2

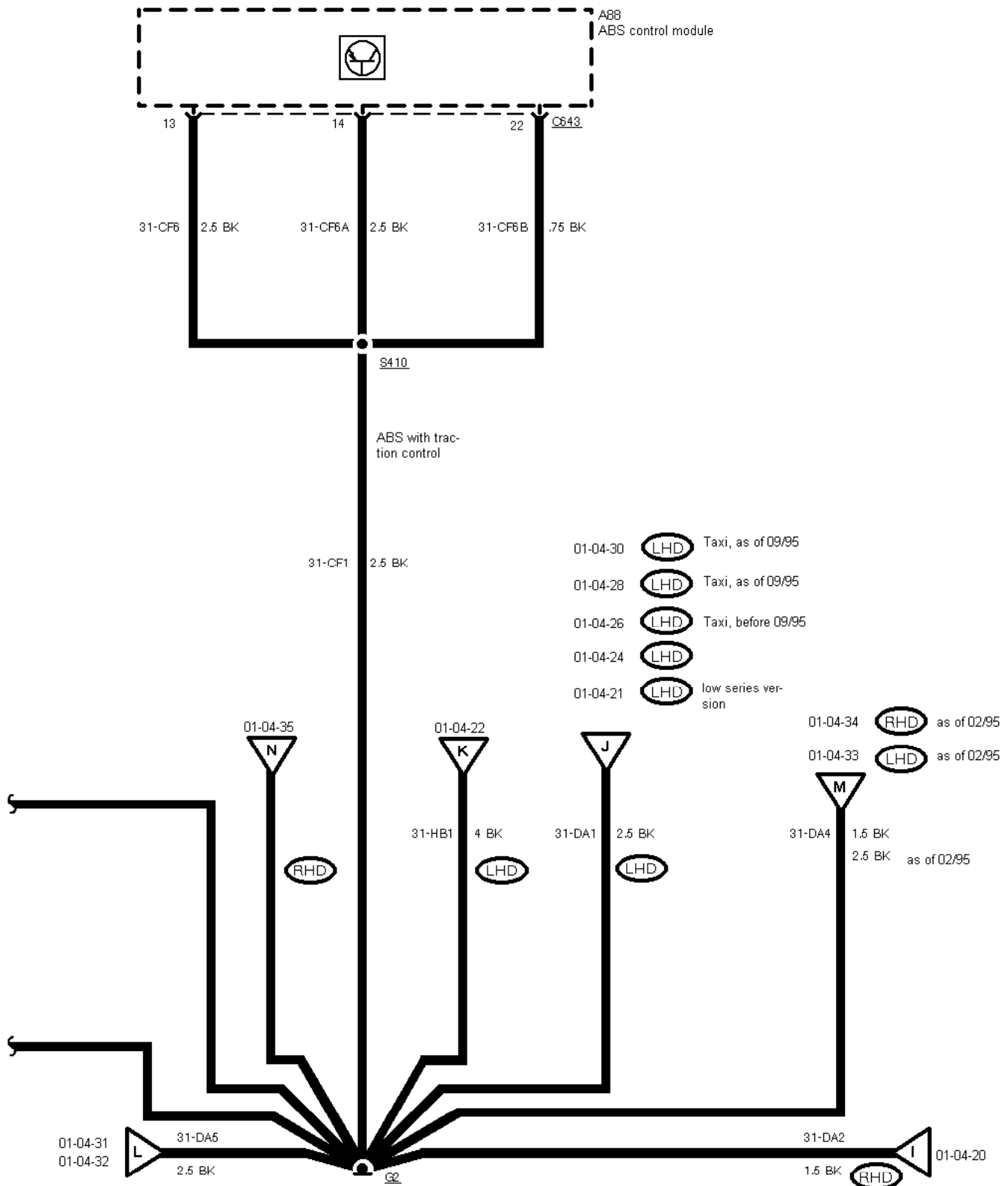

01-04-039 , Ground Distribution , Ground G3

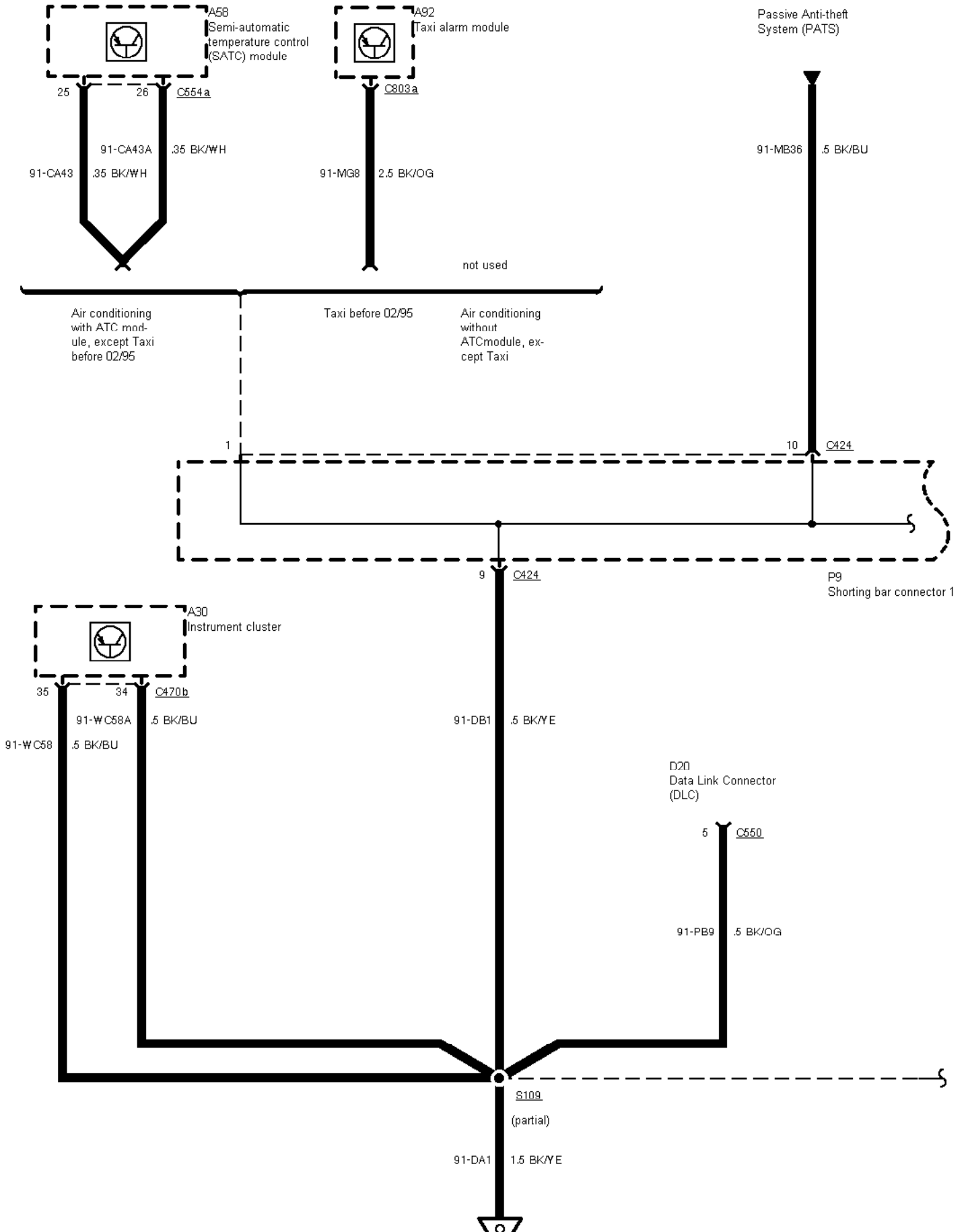



01-04-46

01-04-49

01-04-040 , Ground Distribution , Ground G3

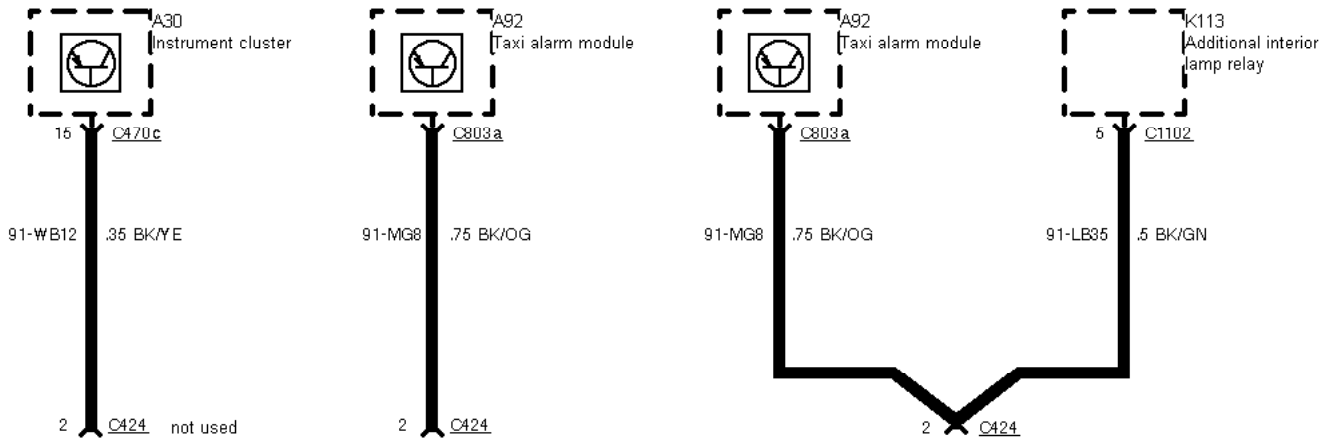

as of 01/97
except RHD Taxi

before 02/95

Taxi as of 02/95

Taxi as of 09/95

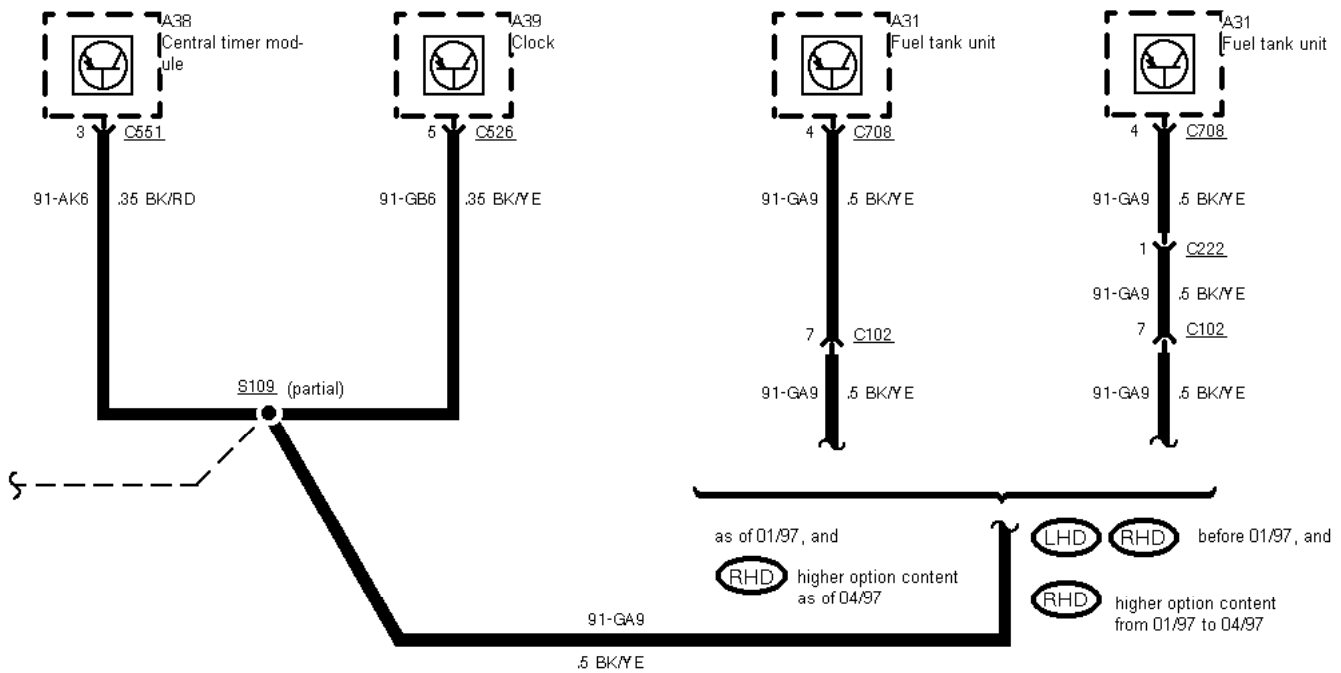
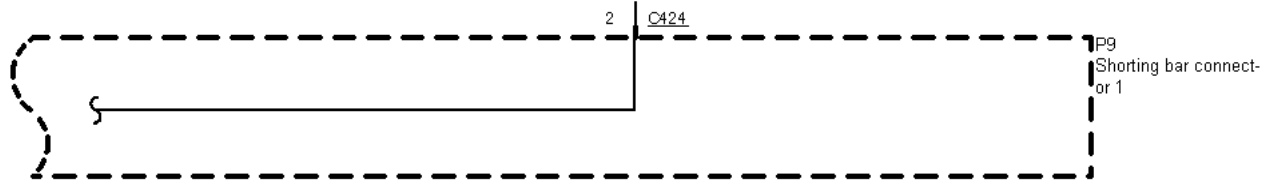

01-04-041 , Ground Distribution , Ground G3

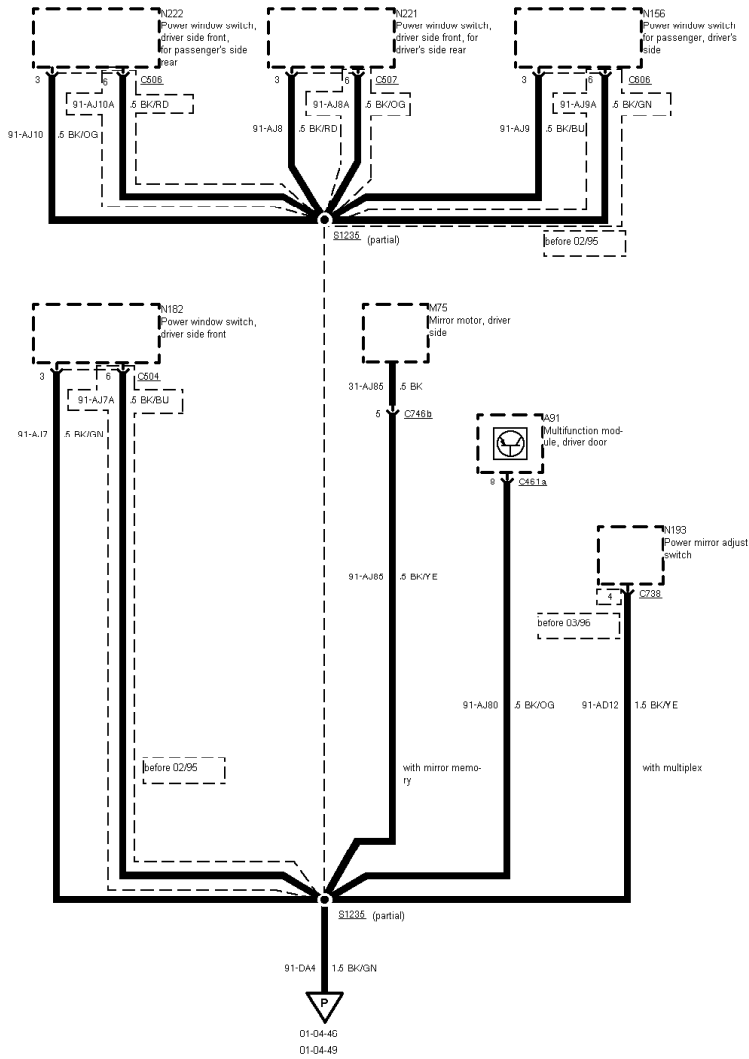

01-04-042 , Ground Distribution , Ground G3 As of 02/95

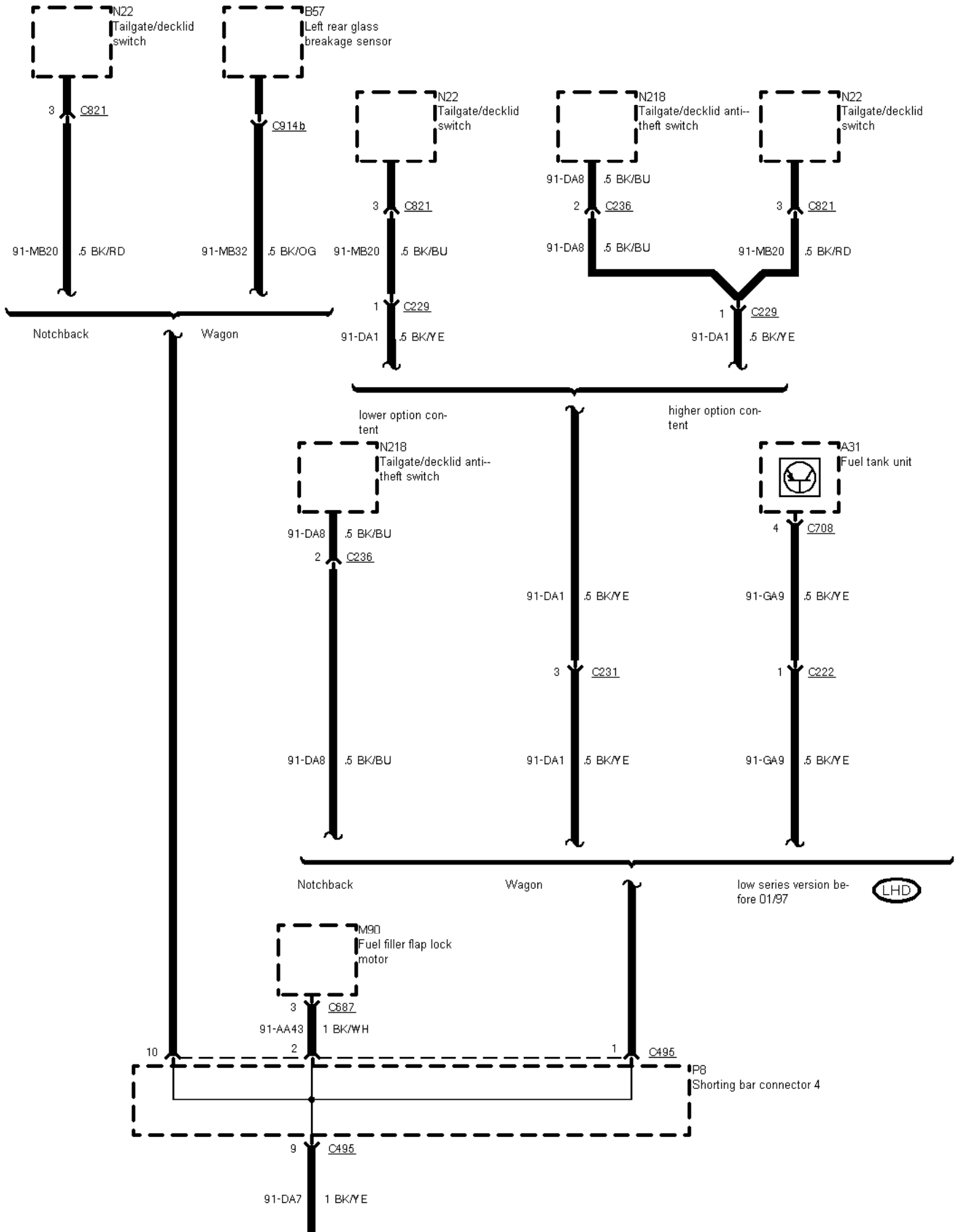



01-04-49

01-04-043 , Ground Distribution , Ground G3 Before 02/95

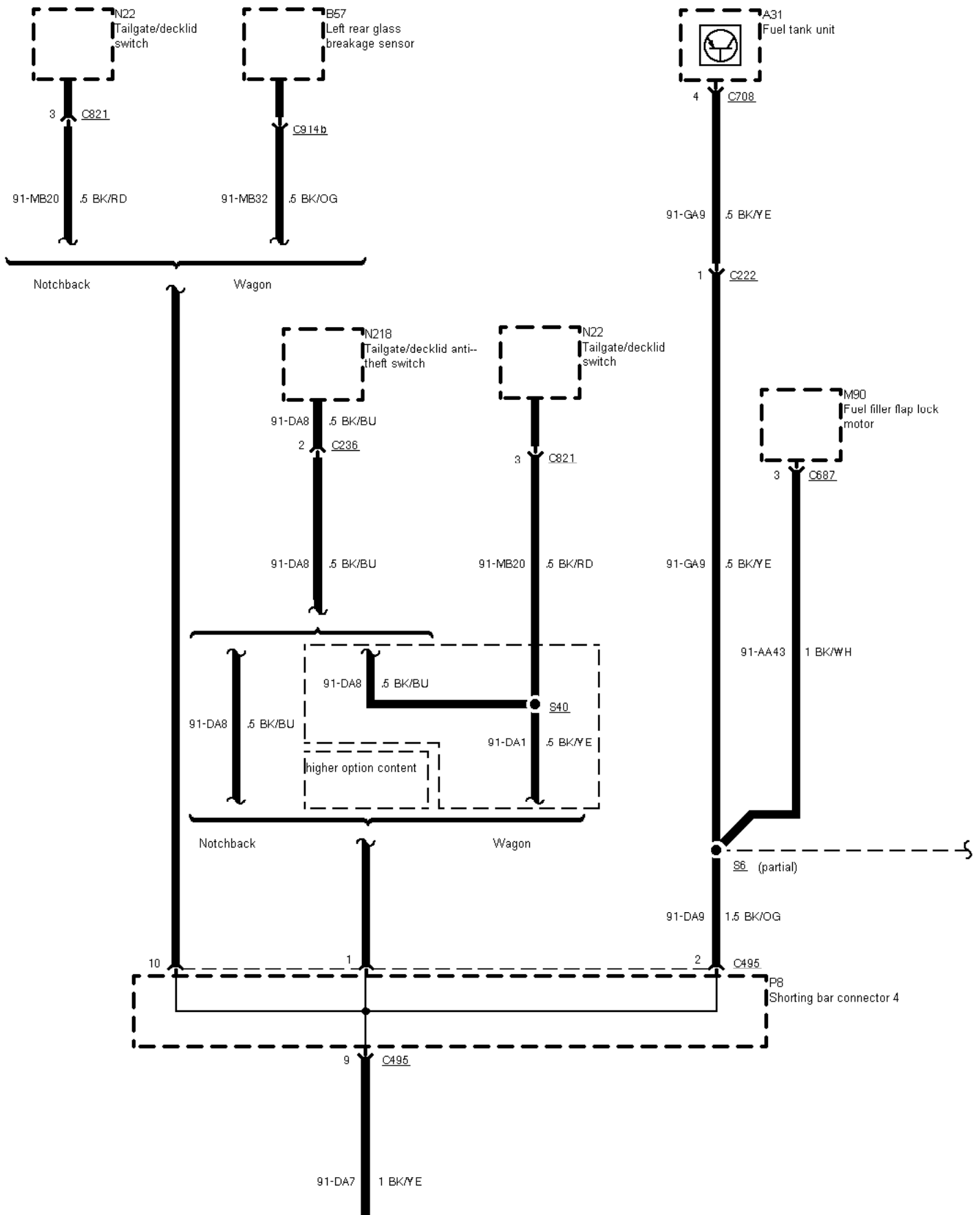



01-04-46

01-04-044 , Ground Distribution , Ground G3 Before 02/95

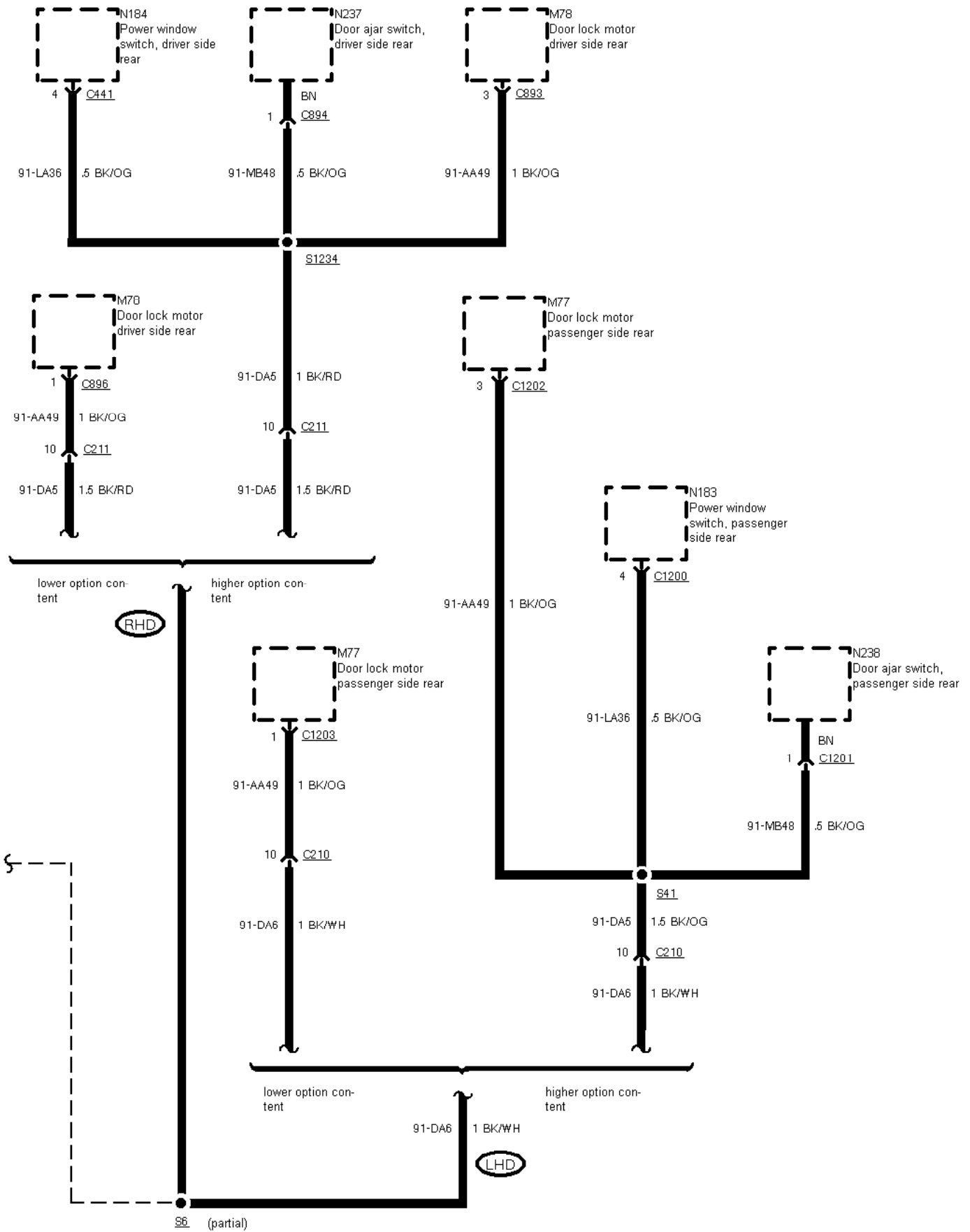

01-04-045 , Ground Distribution , Ground G3 Before 02/95

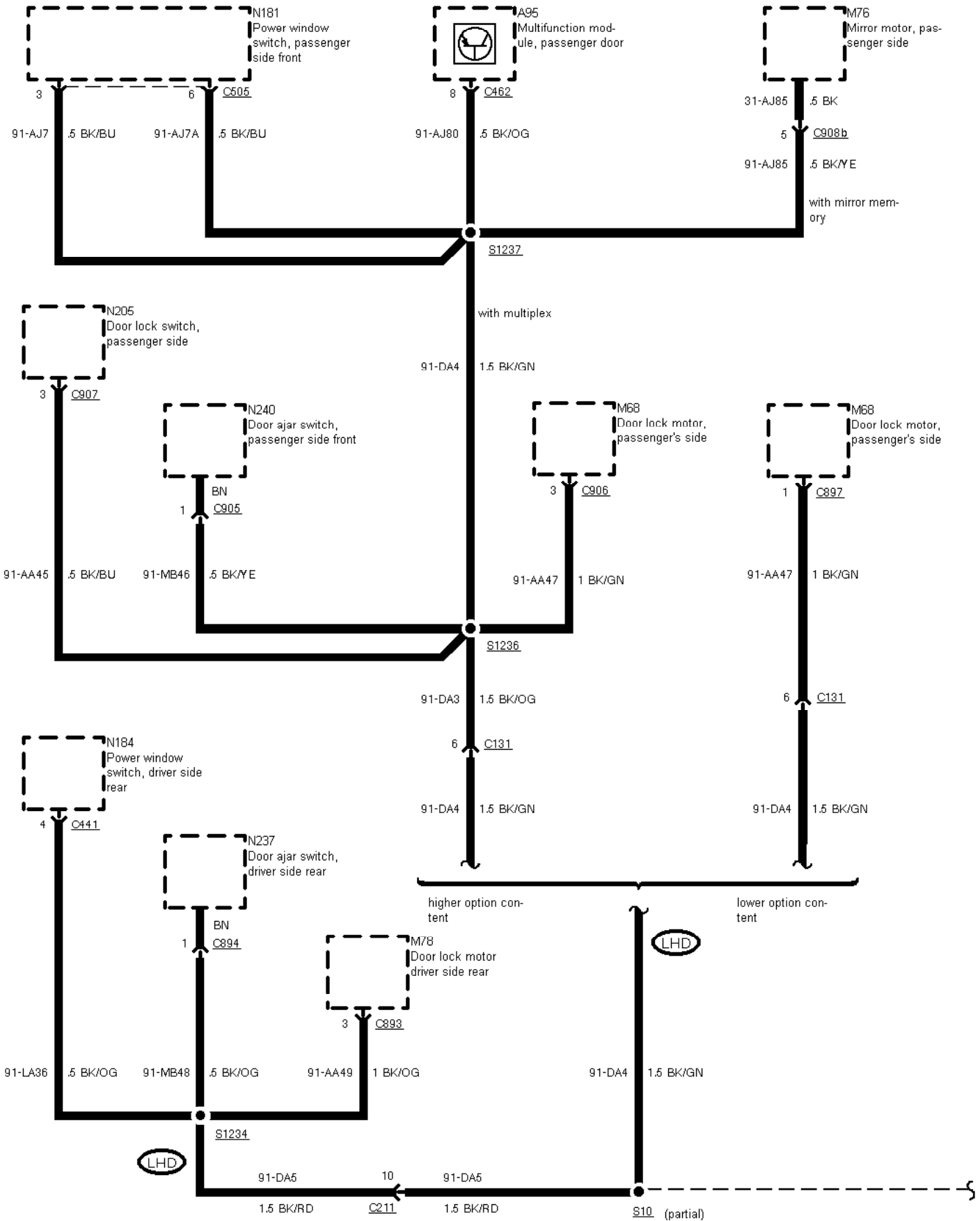

01-04-046 , Ground Distribution , Ground G3

Before 02/95

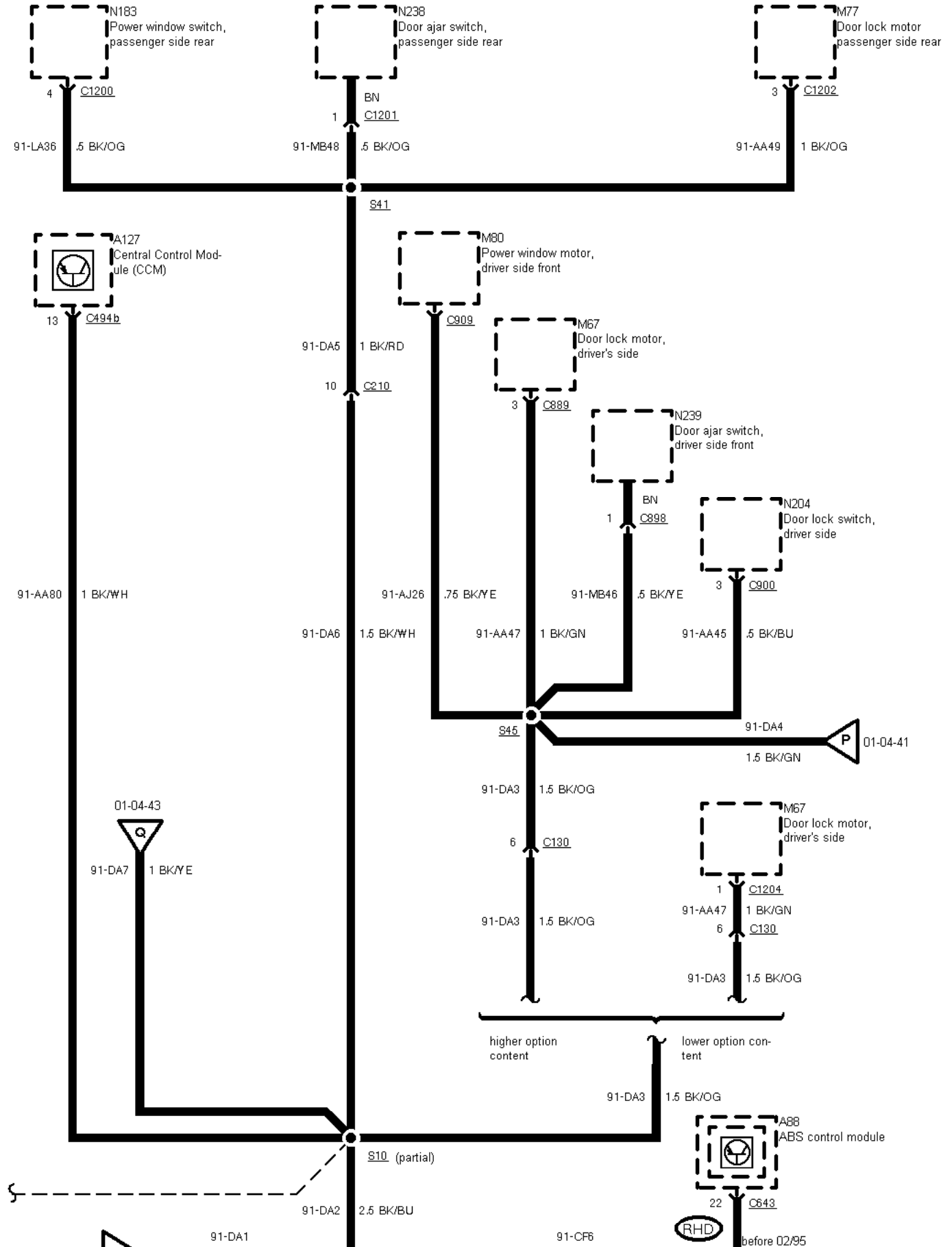

01-04-39



1.5 BK/VE



.75 BK/VE

G3

01-04-047 , Ground Distribution , Ground G3 As of 02/95

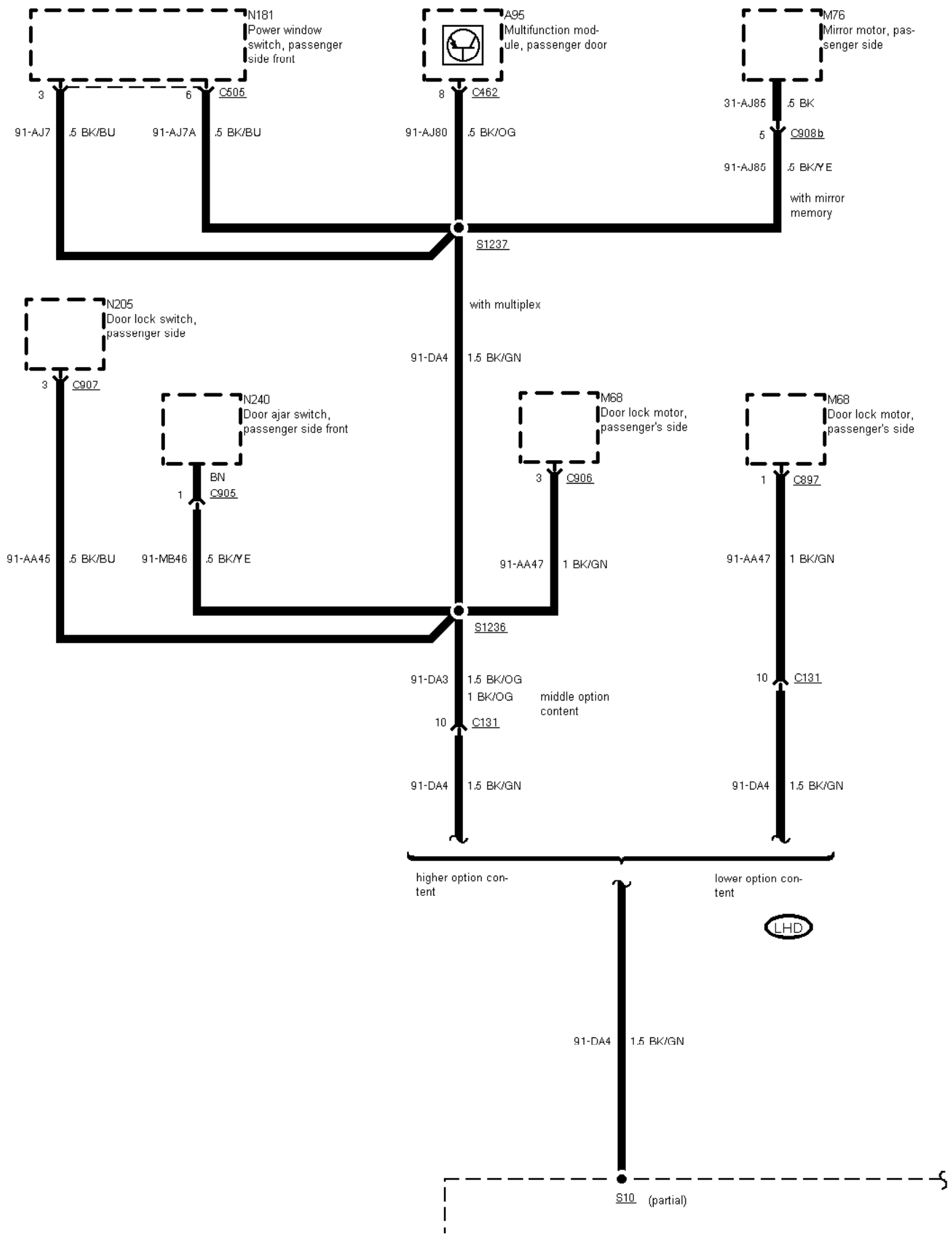



01-04-49

01-04-048 , Ground Distribution , Ground G3

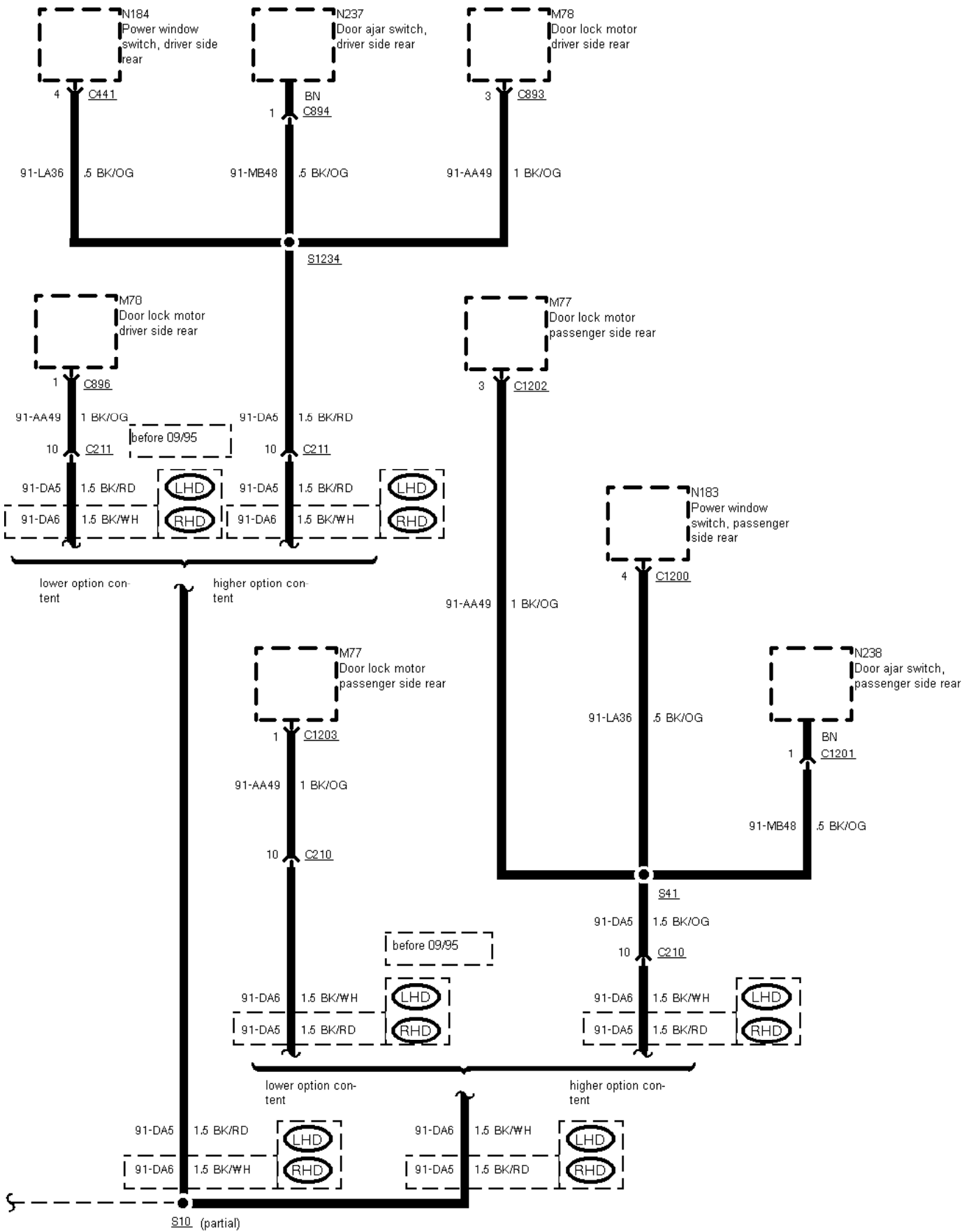

01-04-049 , Ground Distribution , Ground G3 As of 02/95

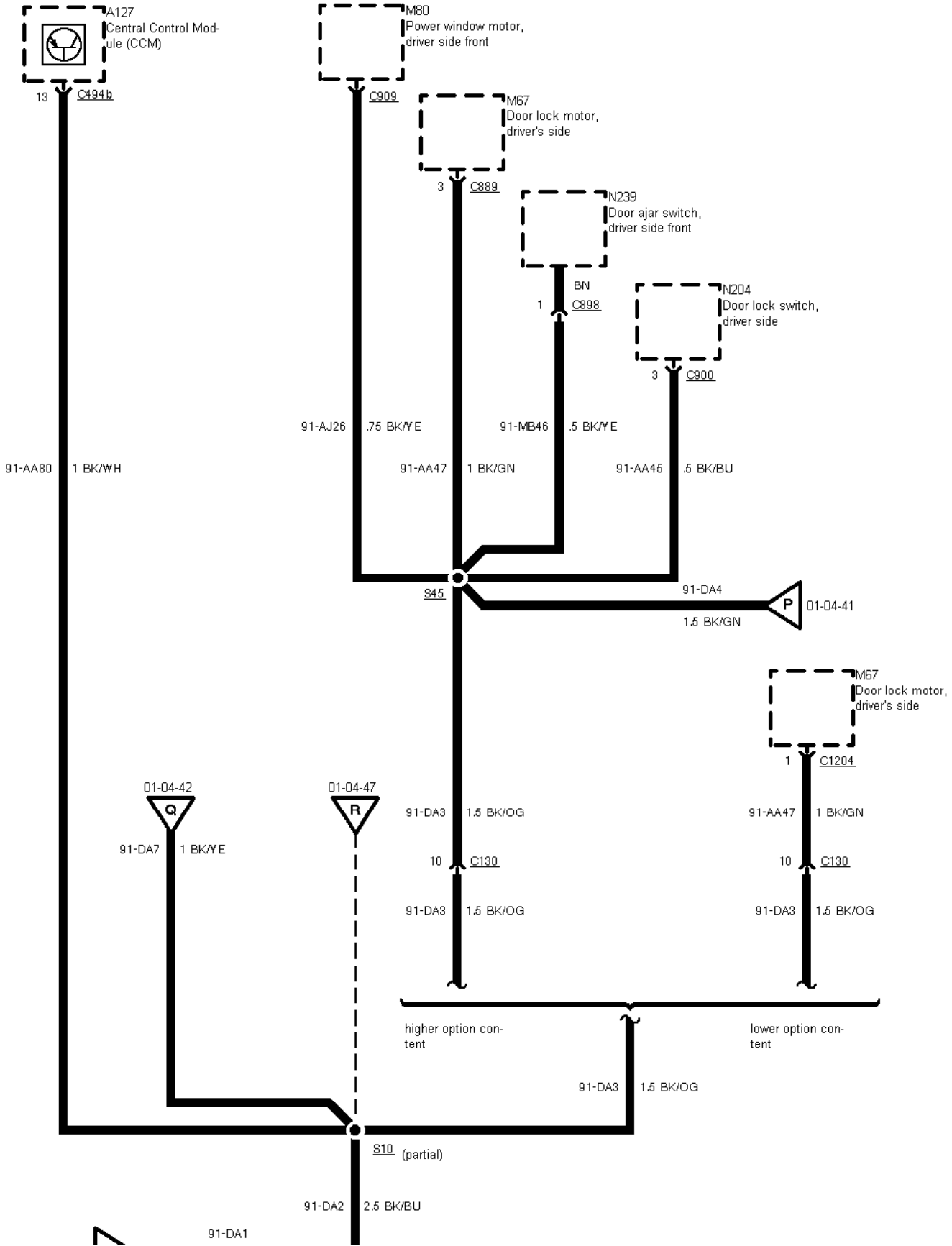

01-04-39

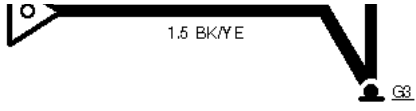

01-04-050 , Ground Distribution , Ground G4

Left-hand-drive vehicles with speed control and with headlamp washer

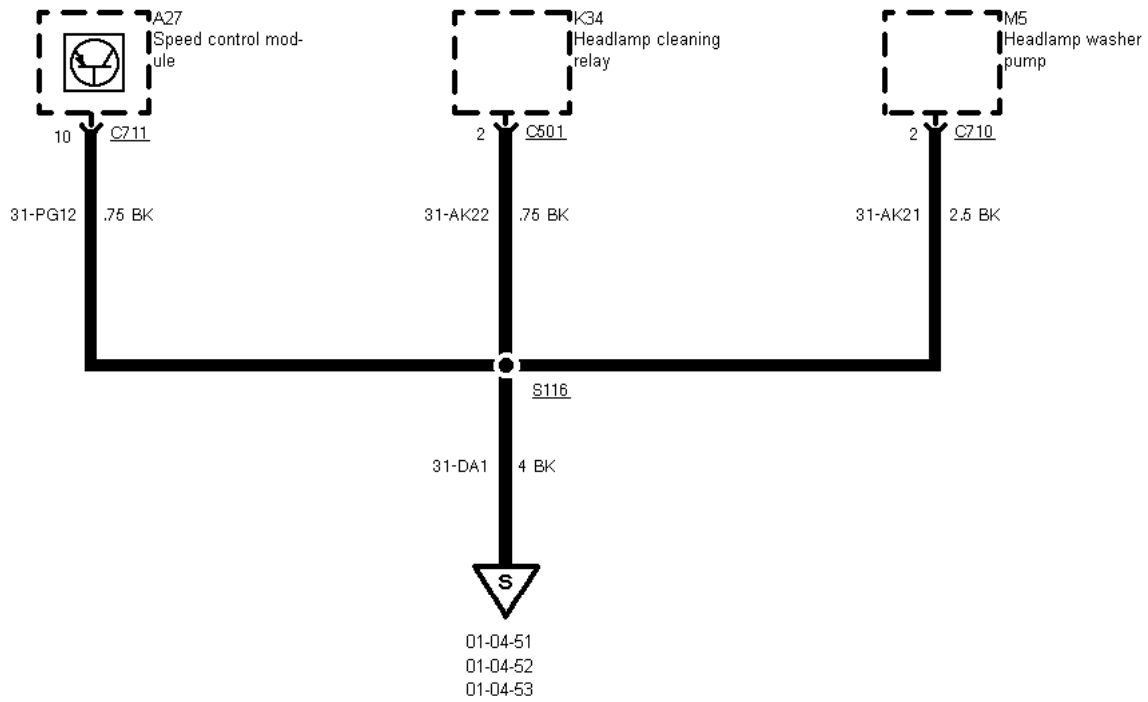

Left-hand-drive vehicles

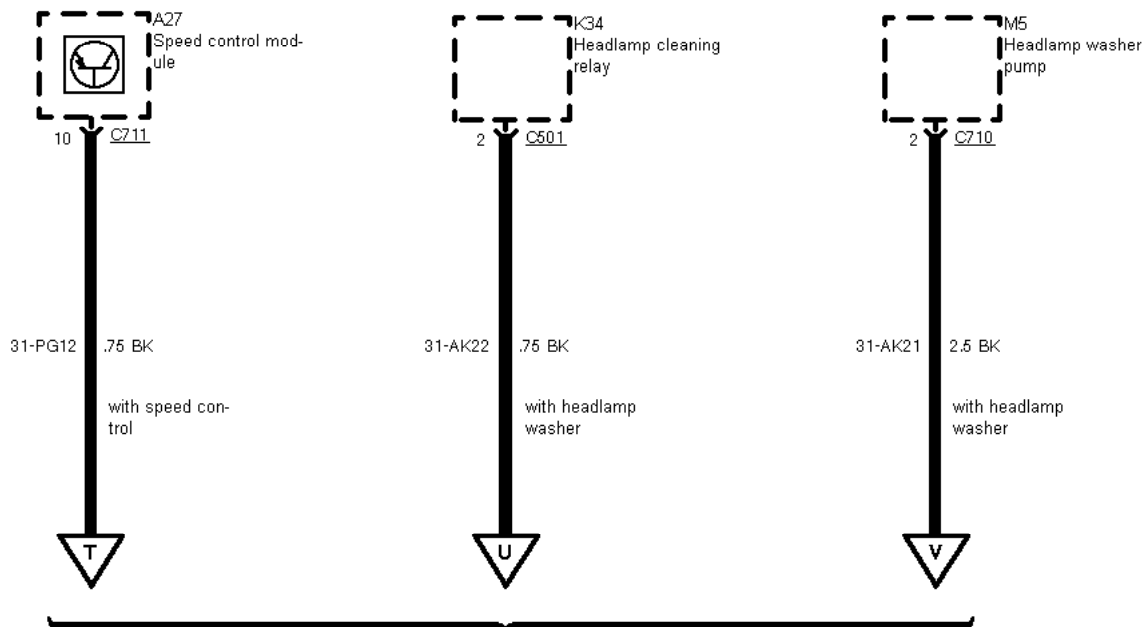

01-04-51
01-04-52
01-04-53

01-04-051 , Ground Distribution , Ground G4

Petrol engines, with air conditioning

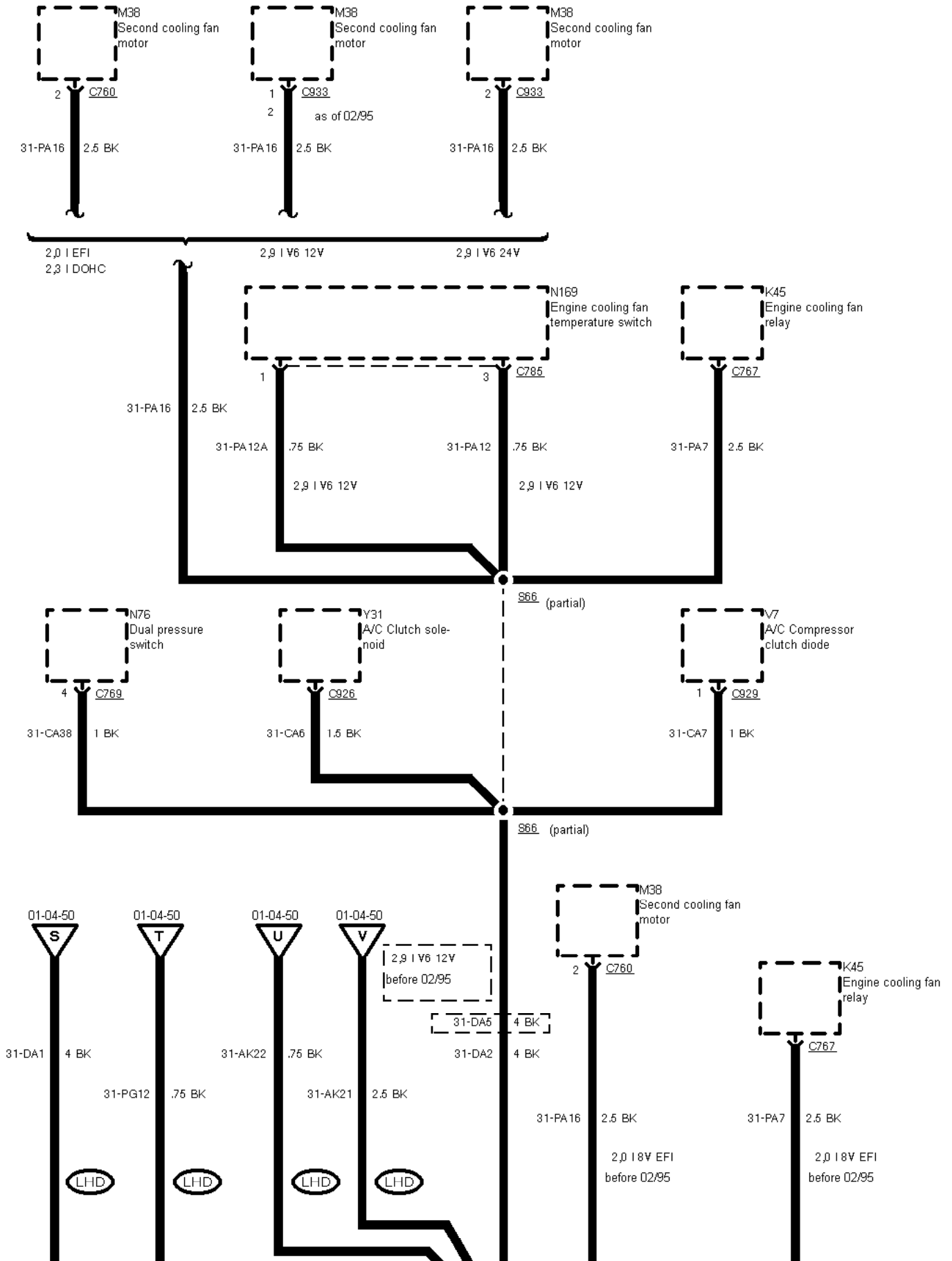



01-04-052 , Ground Distribution , Ground G4

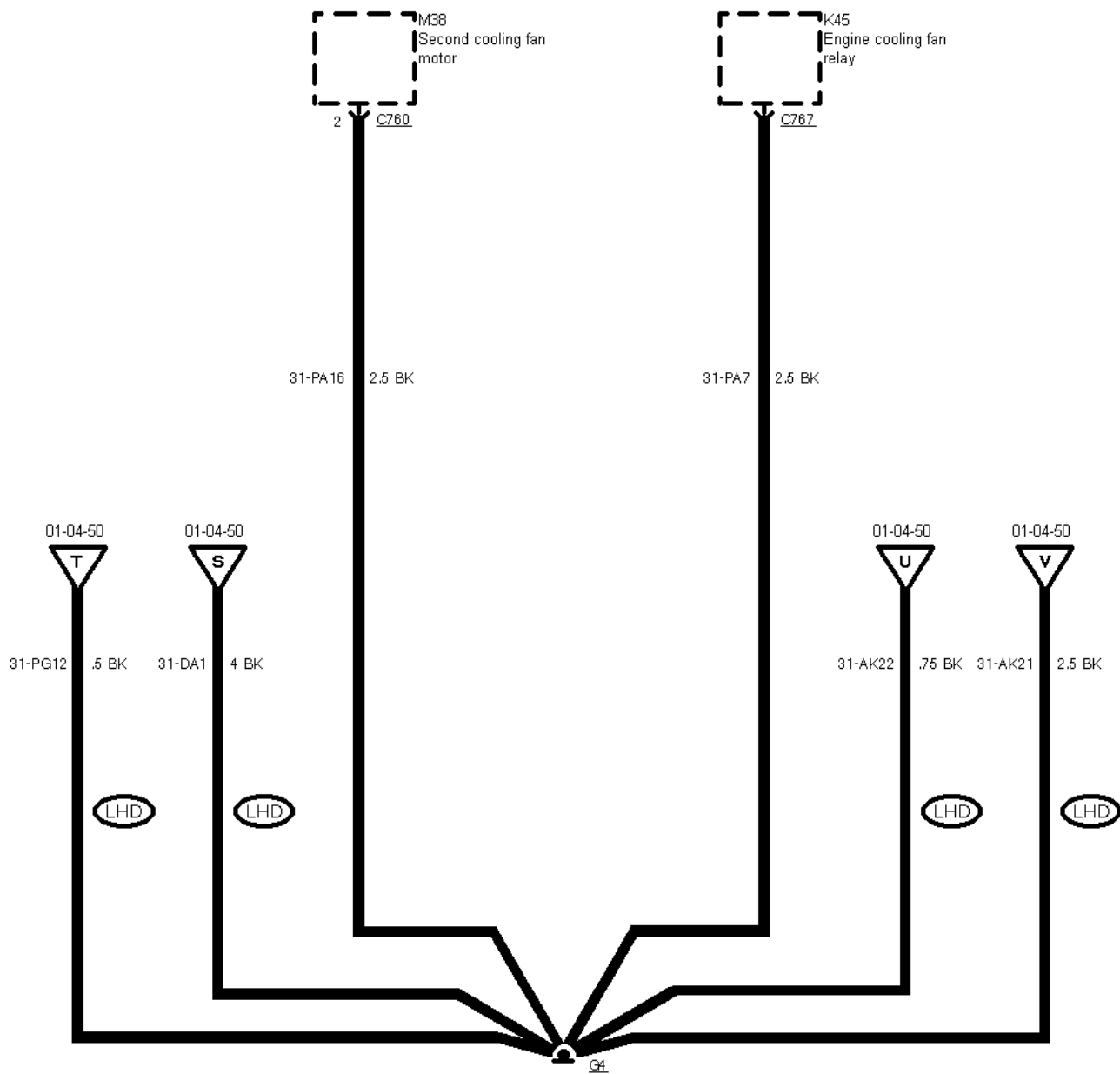

01-04-053 , Ground Distribution , Ground G4

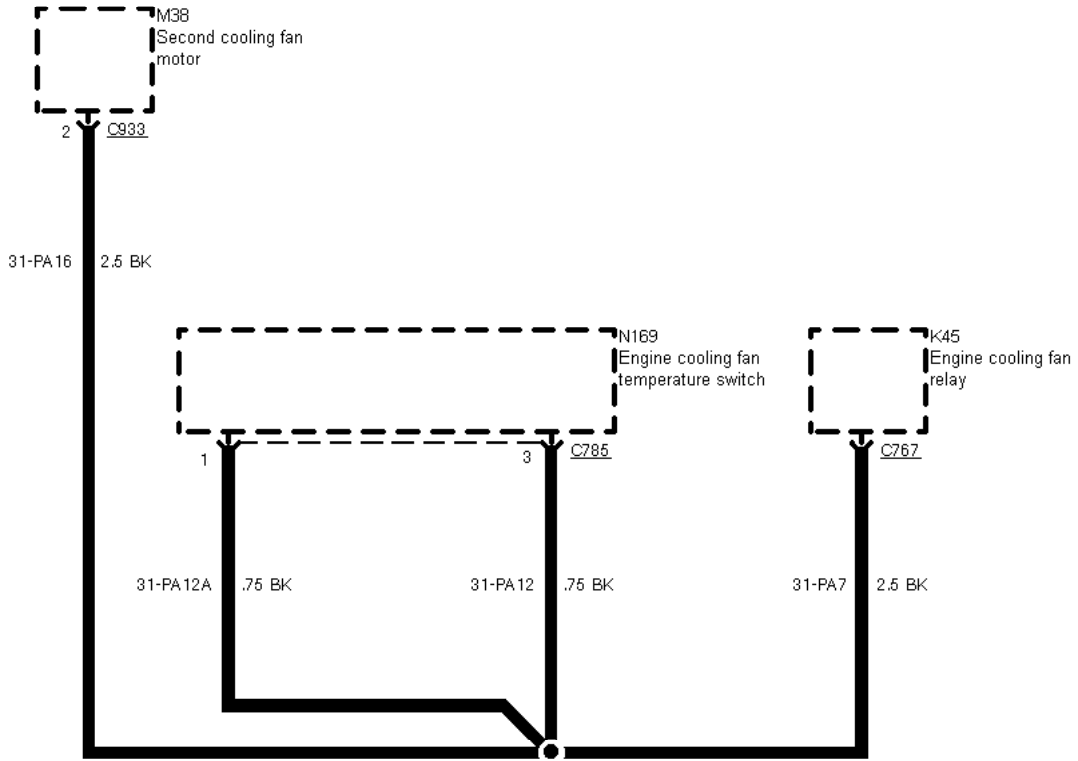

S66
(partial)

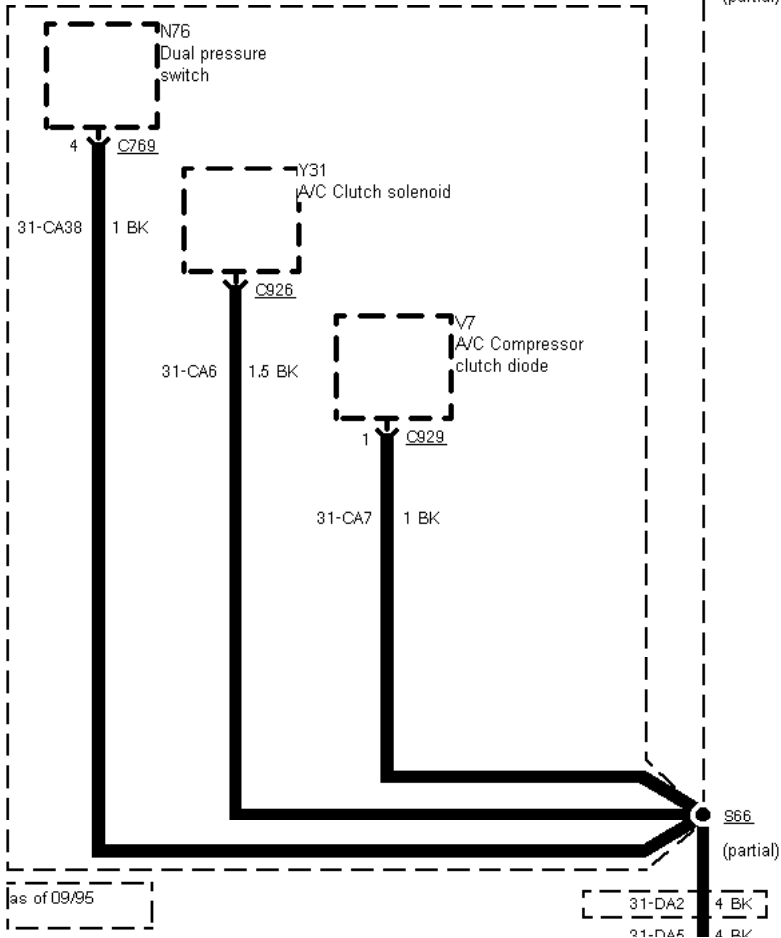

as of 09/95

31-DA2 4 BK
31-DA5 4 BK

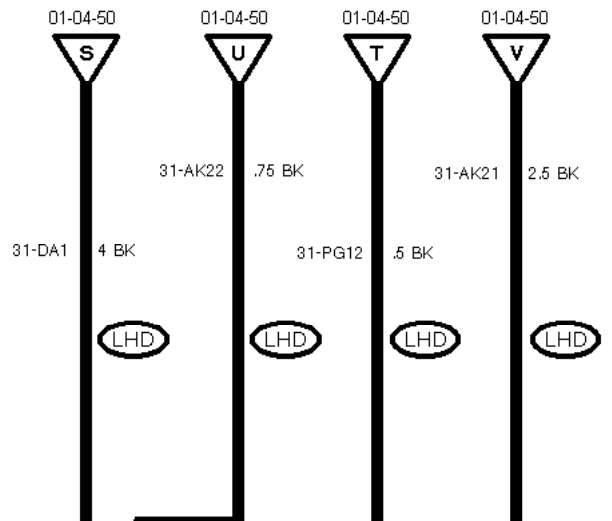



01-04-054 , Ground Distribution , Ground G4 2,5 l TCI Diesel with air conditioning, as of 09/96

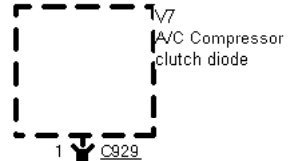
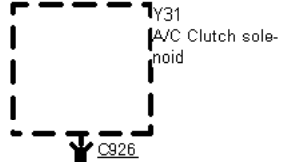
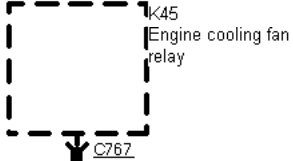
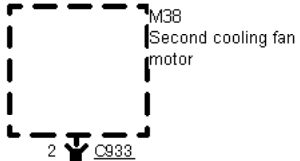

31-PA16 4 BK

31-PA7 4 BK

31-CA6 1.5 BK

31-CA7 1 BK

S400

31-DA2 6 BK



G4

01-04-055 , Ground Distribution , Ground G4 2,5 l TCI Diesel without air conditioning, as of 09/96

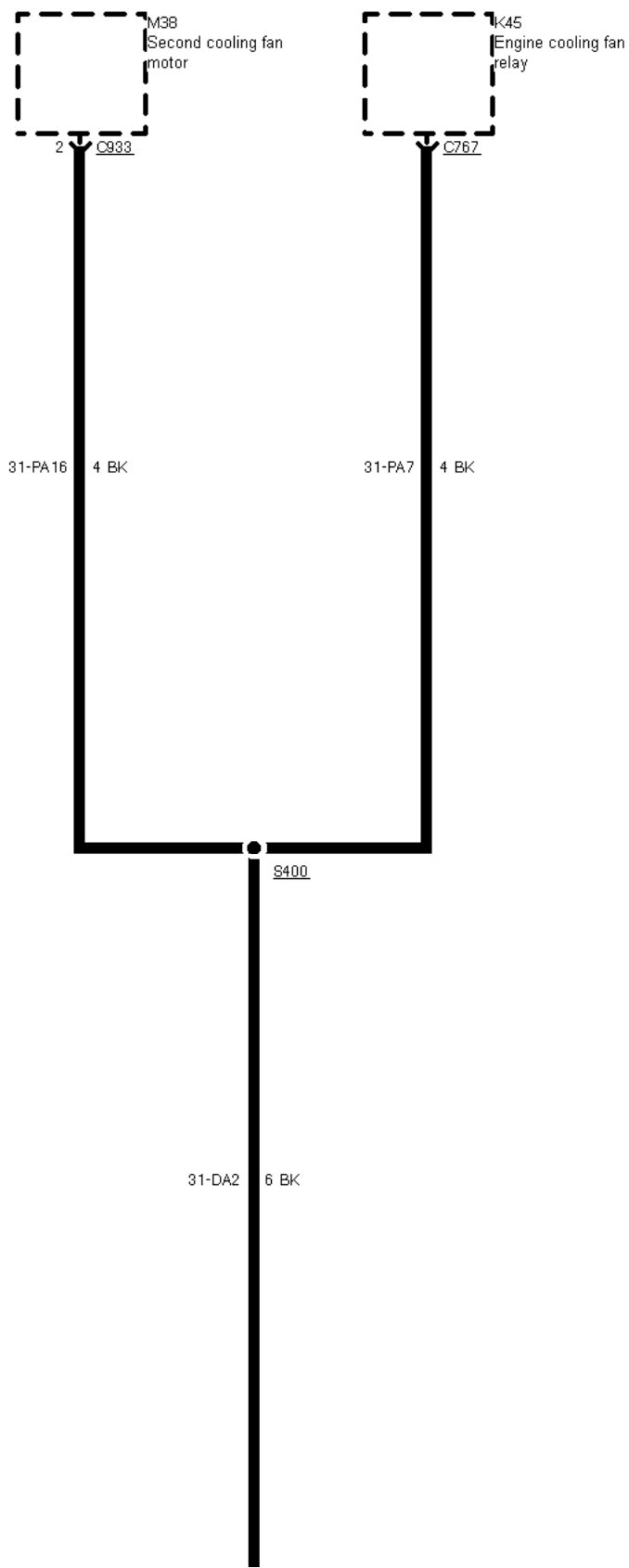



G4

01-04-056 , Ground Distribution , Ground G5

Right-hand-drive vehicles as of 03/96

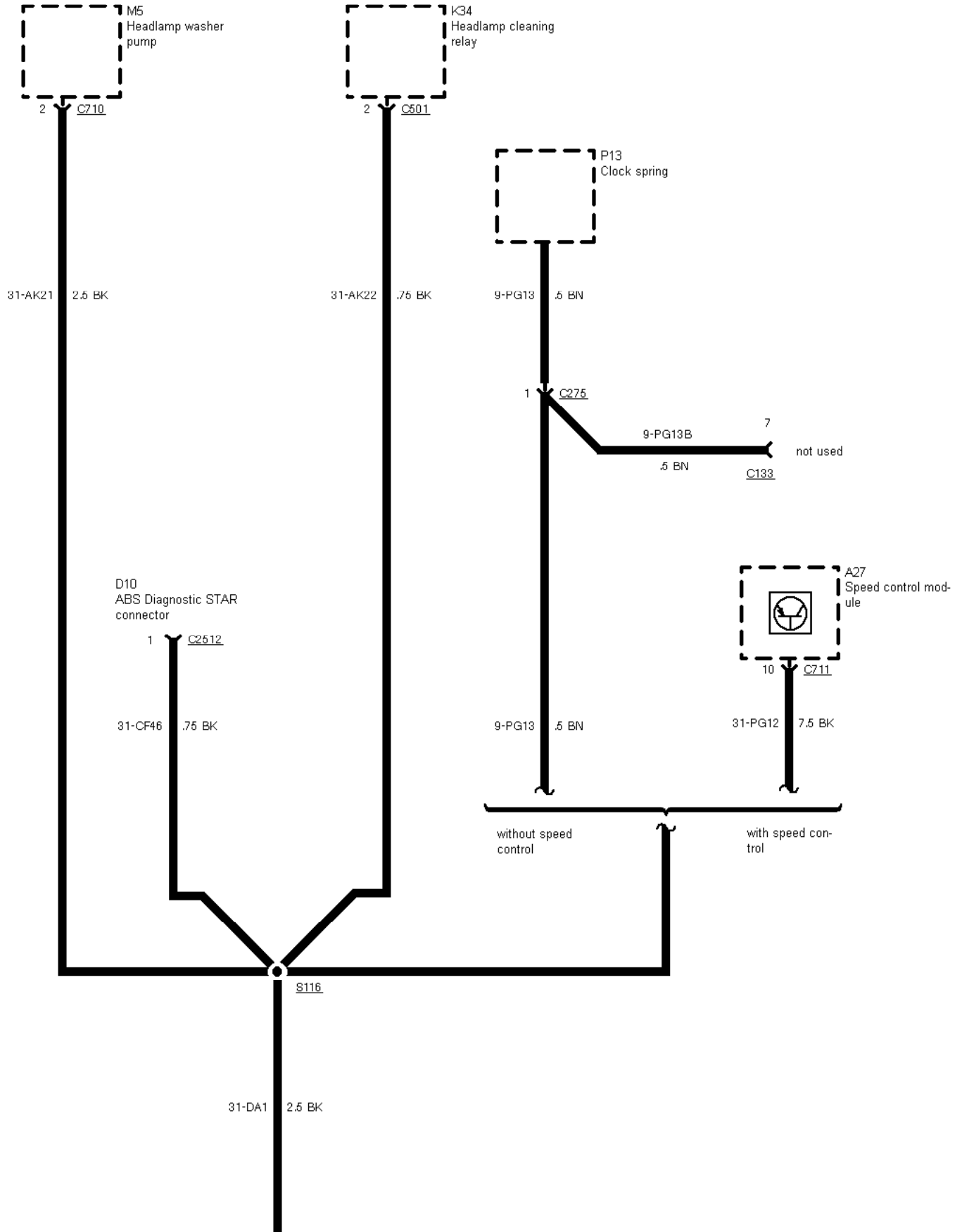



01-04-60
01-04-62

01-04-057 , Ground Distribution , Ground G5

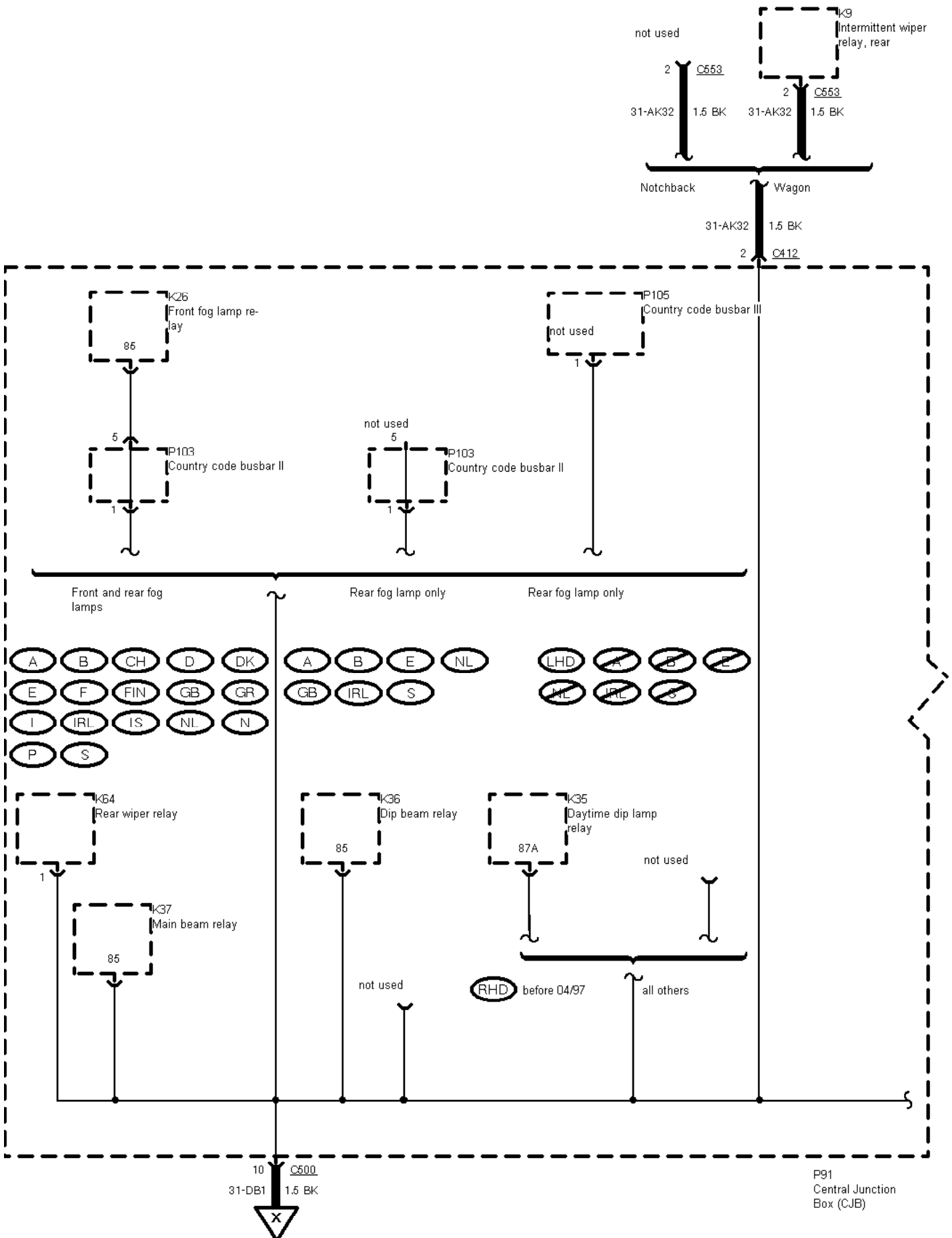

01-04-59 **RHD** before 01/97
01-04-60 **LHD** before 01/97
01-04-61 as of 01/97

01-04-058 , Ground Distribution , Ground G5

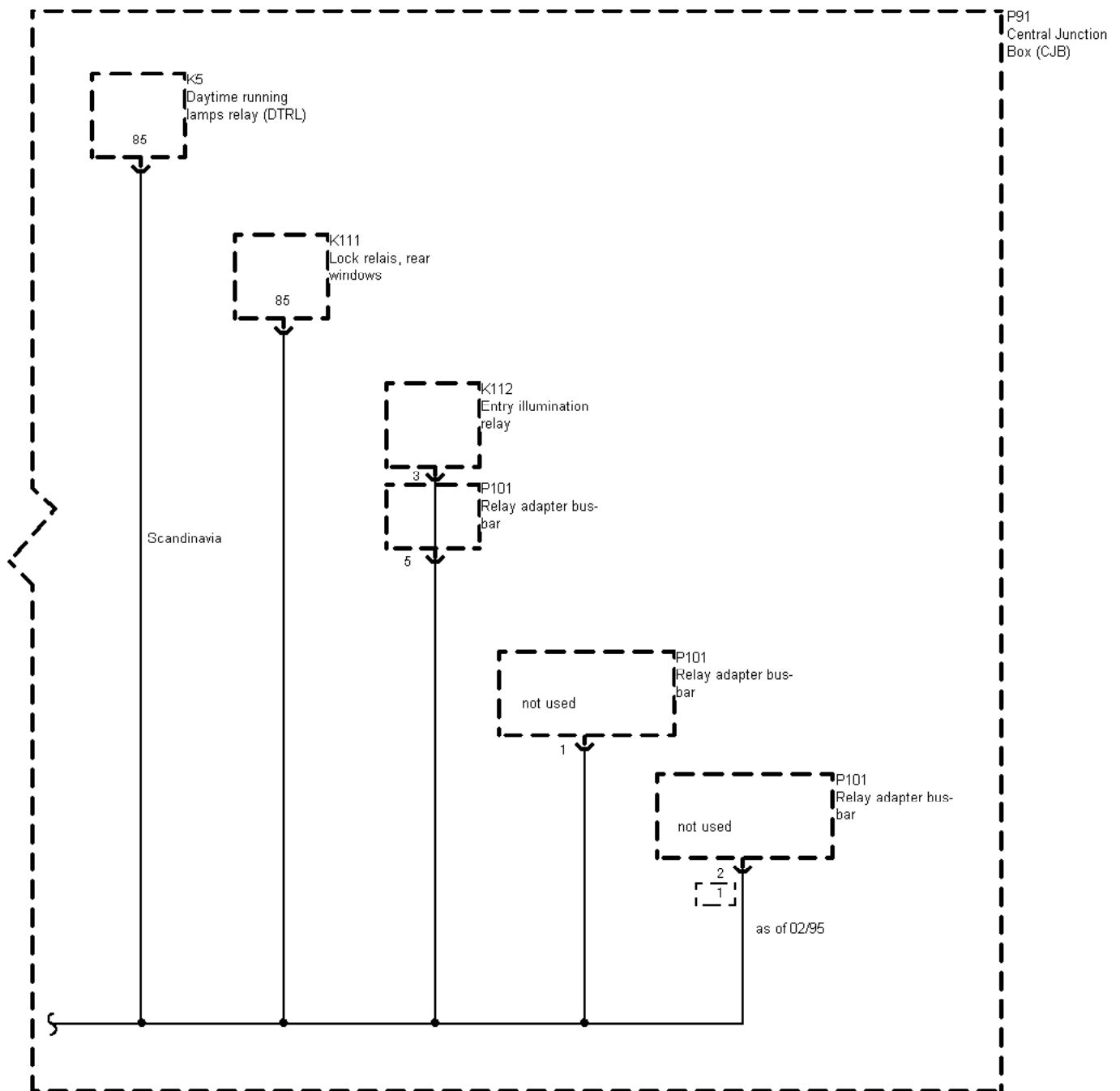

01-04-059 , Ground Distribution , Ground G5 Before 01/97

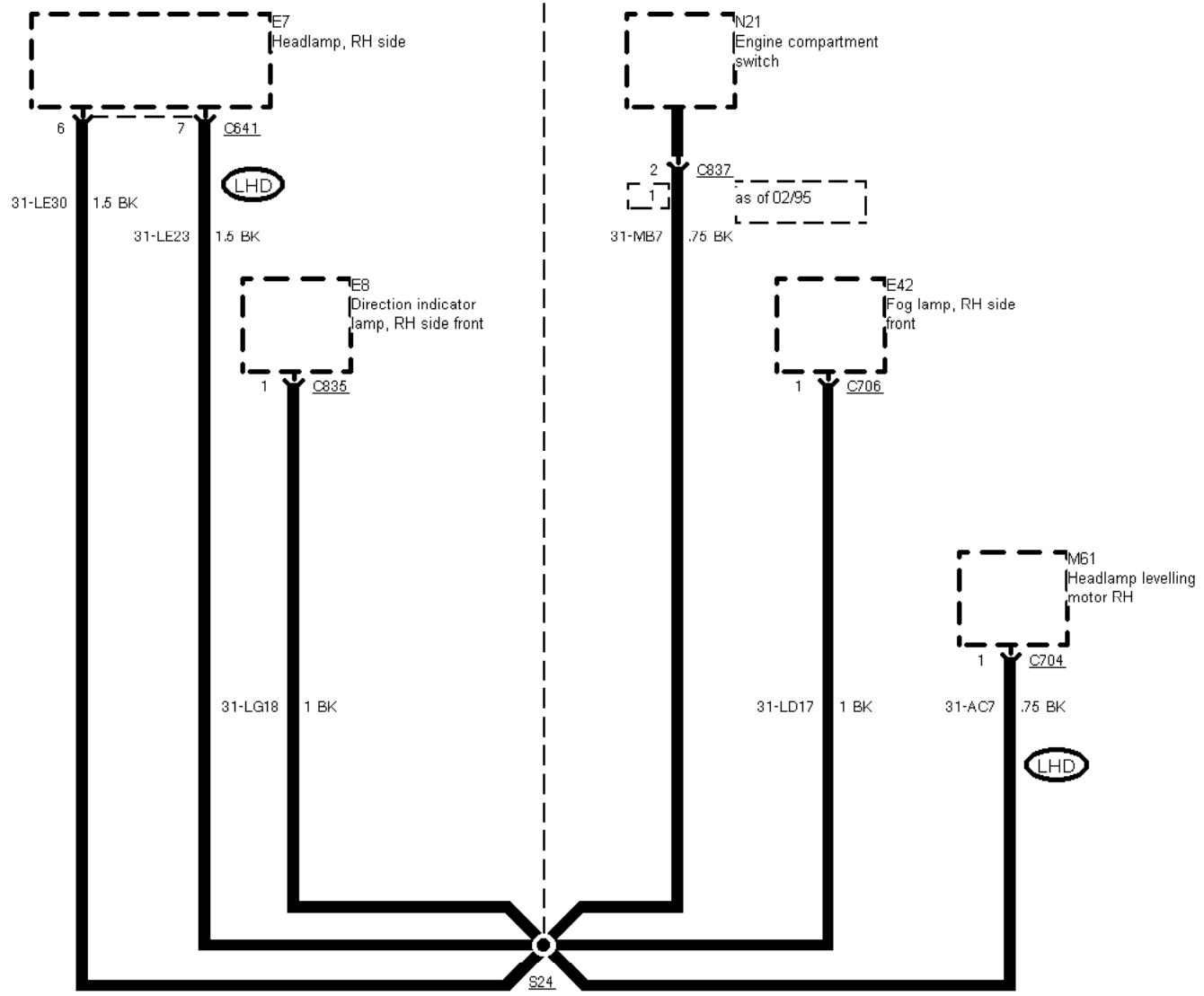
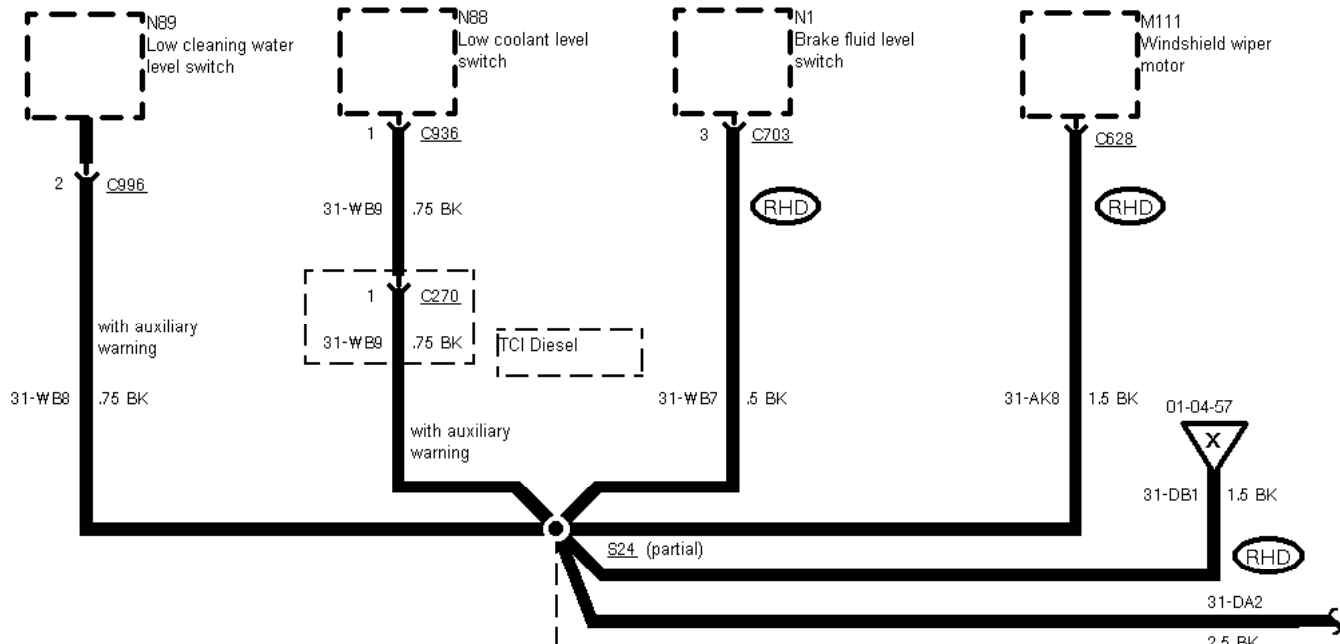

(partial)

01-04-060 , Ground Distribution , Ground G5 Before 01/97

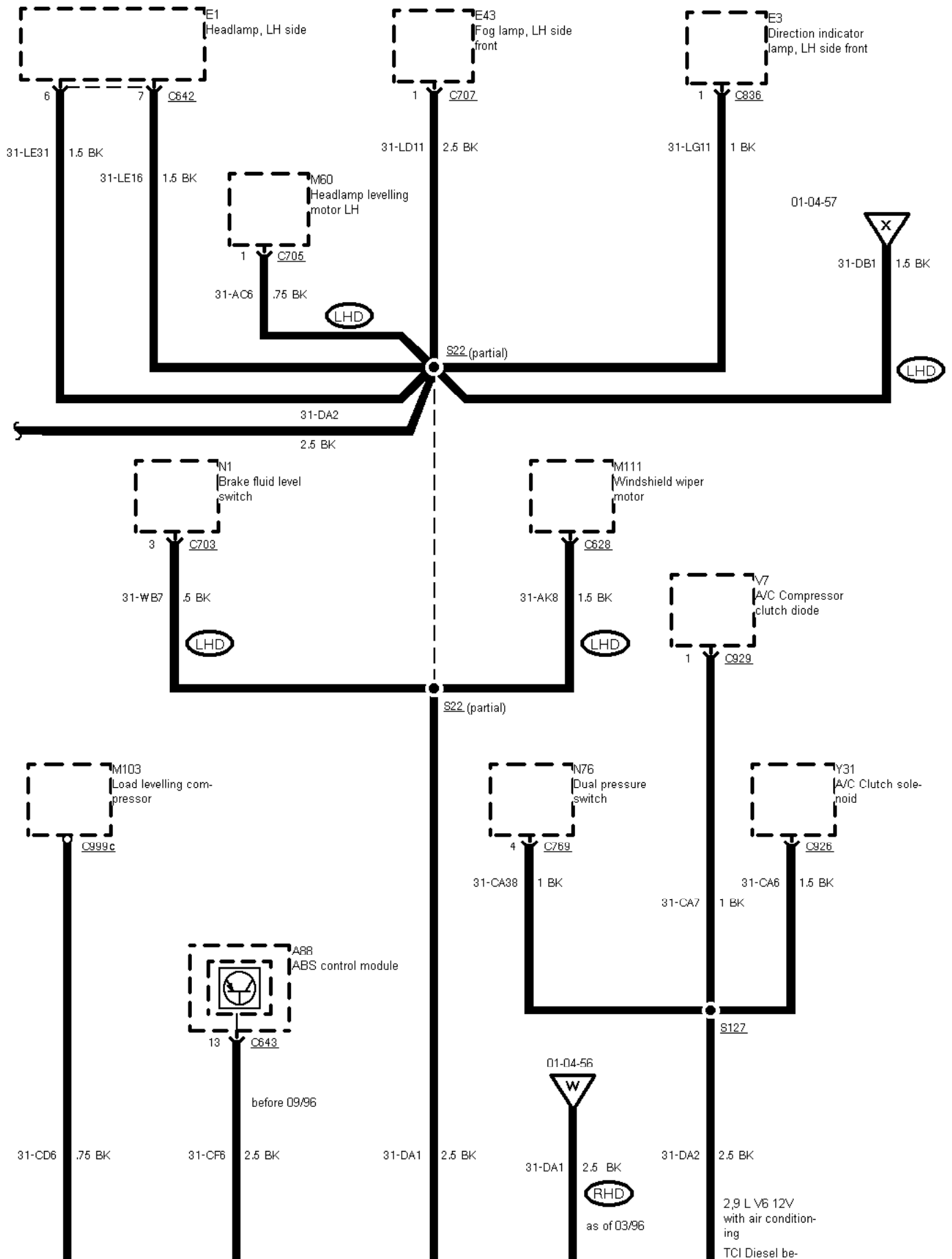



01-04-061 , Ground Distribution , Ground G5 As of 01/97

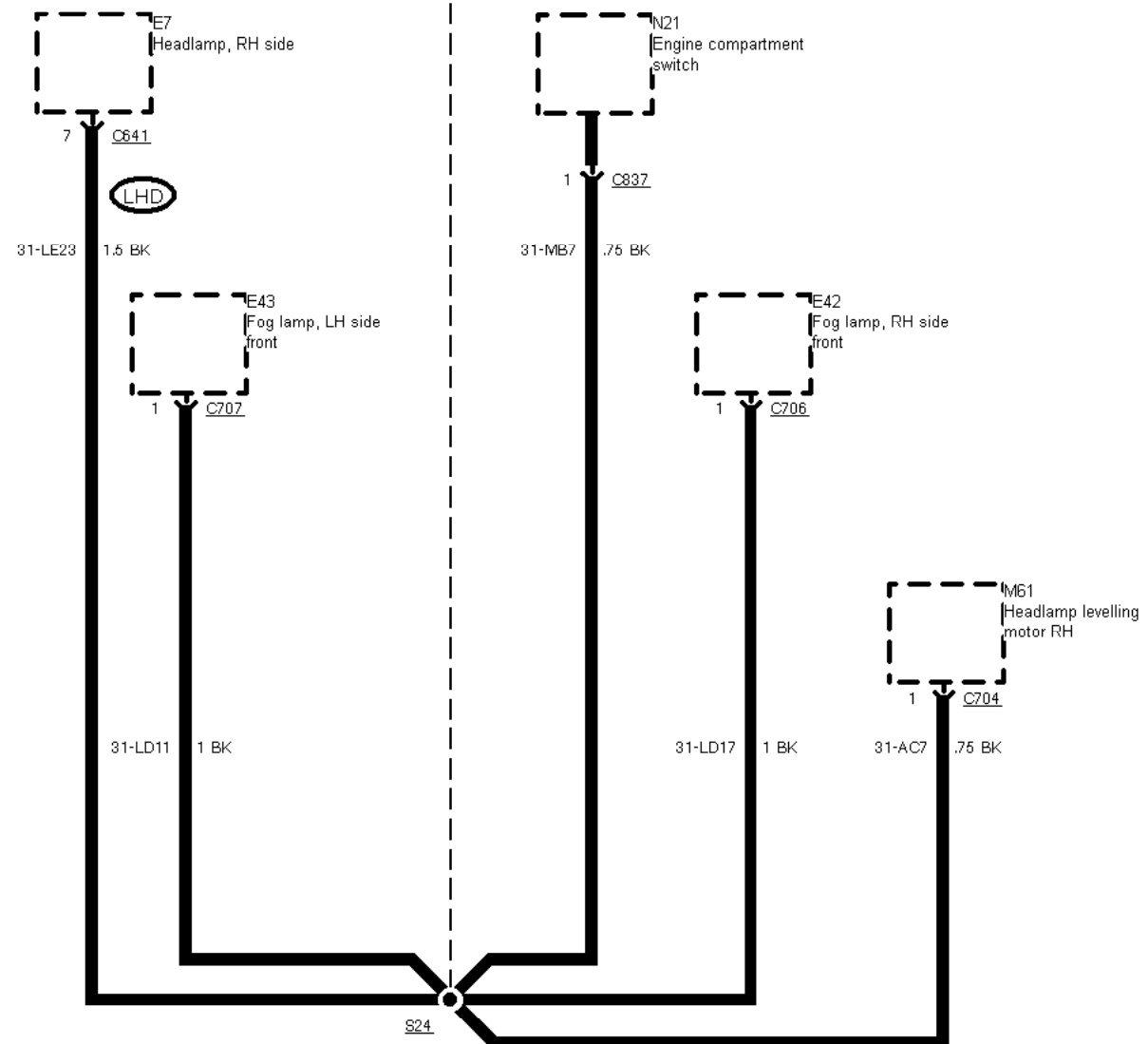
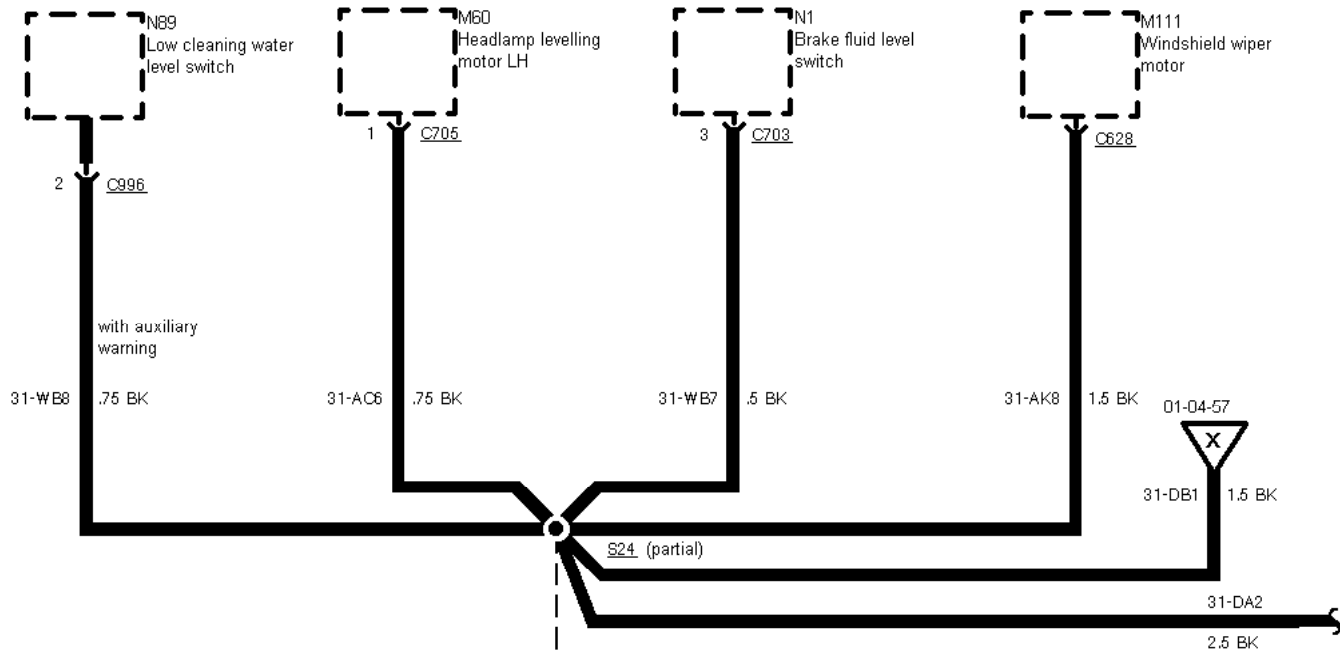

(partial)

01-04-062 , Ground Distribution , Ground G5 As of 01/97

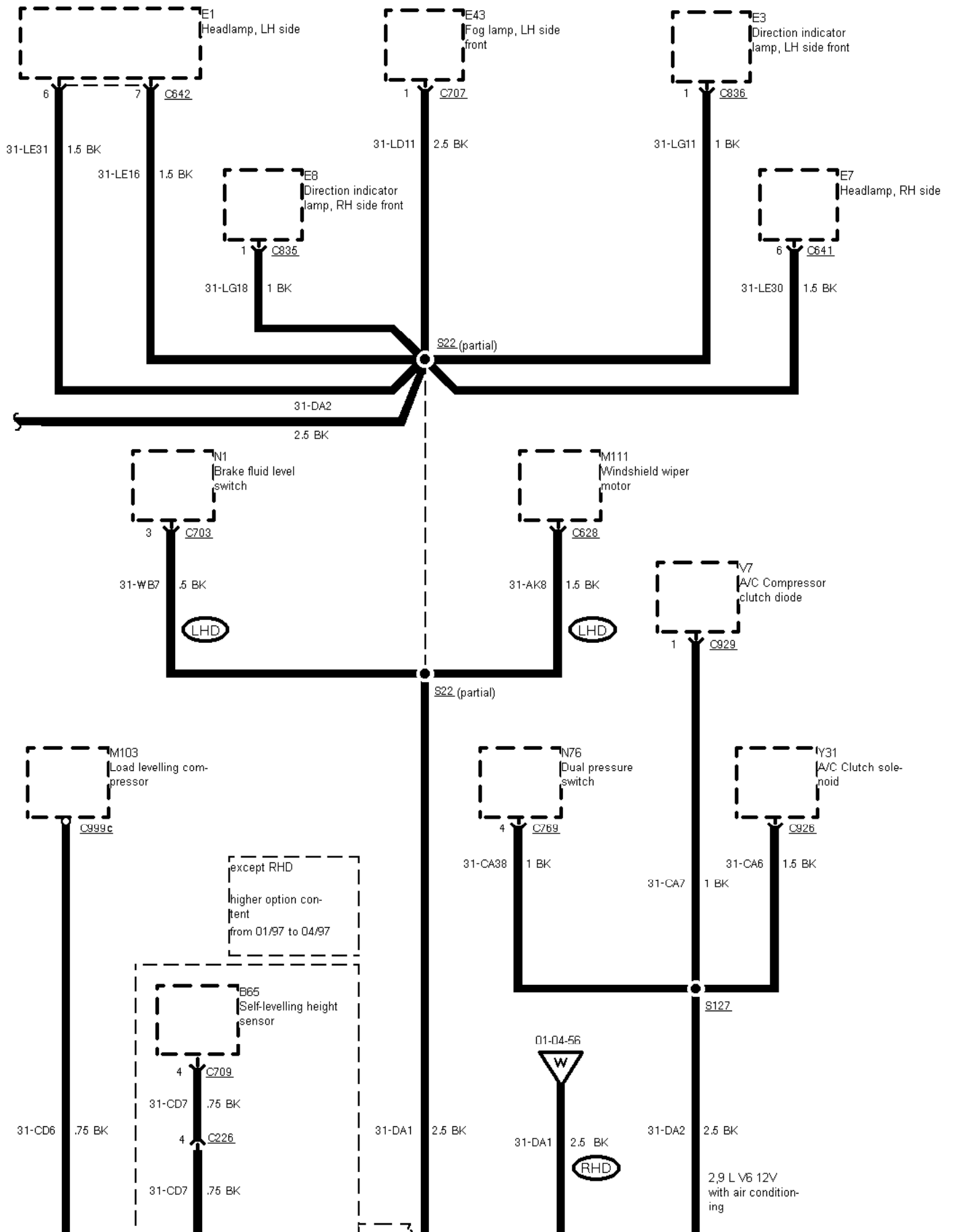



01-04-063 , Ground Distribution , Ground G6

Before 04/98

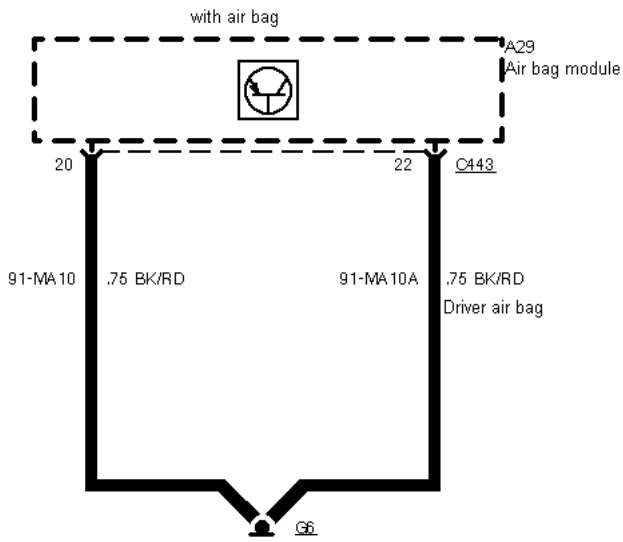

without air bag before 02/95

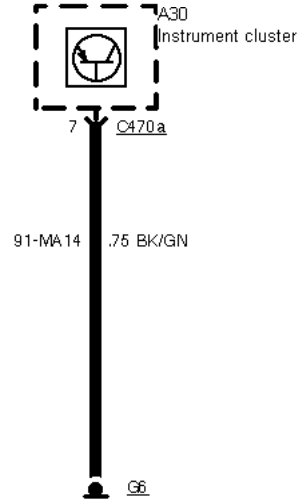

As of 04/98

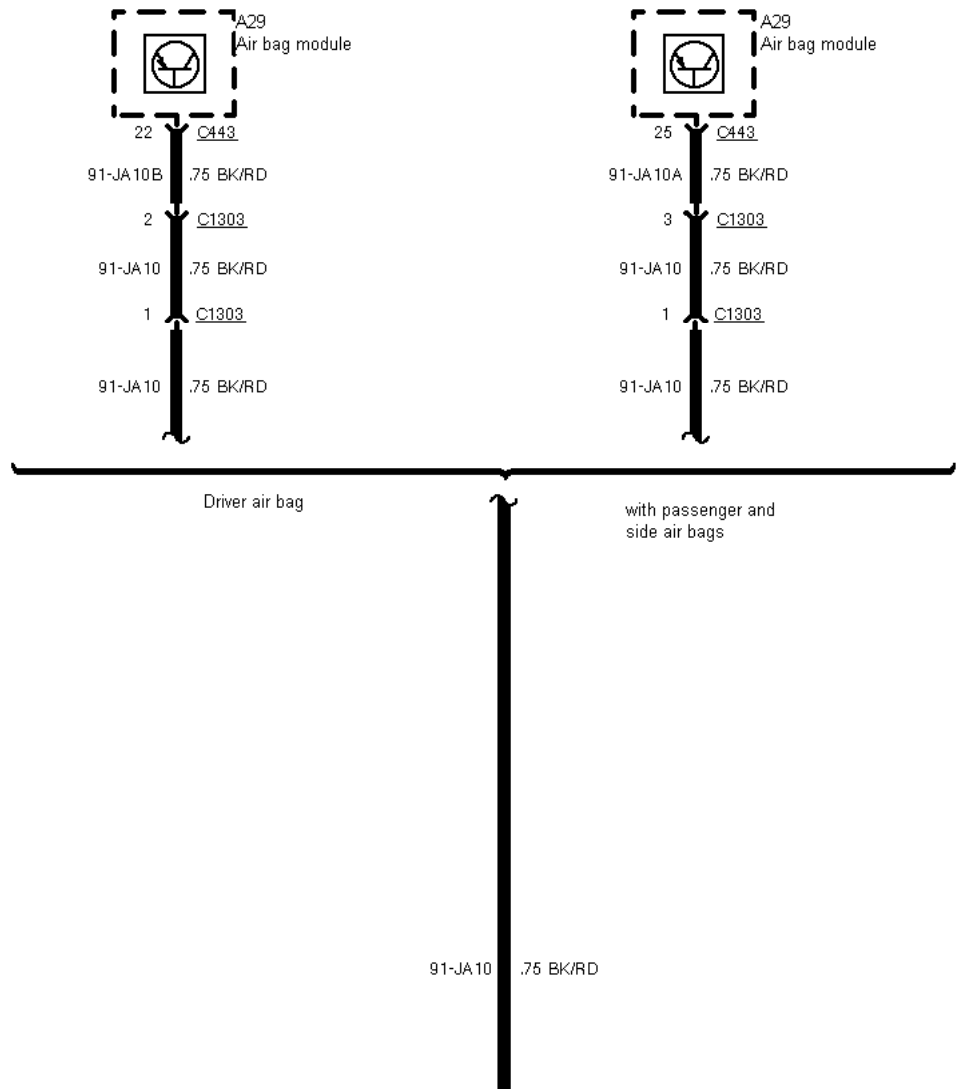



01-04-064 , Ground Distribution , Ground G7 As of 02/95, except 2,9 I V6

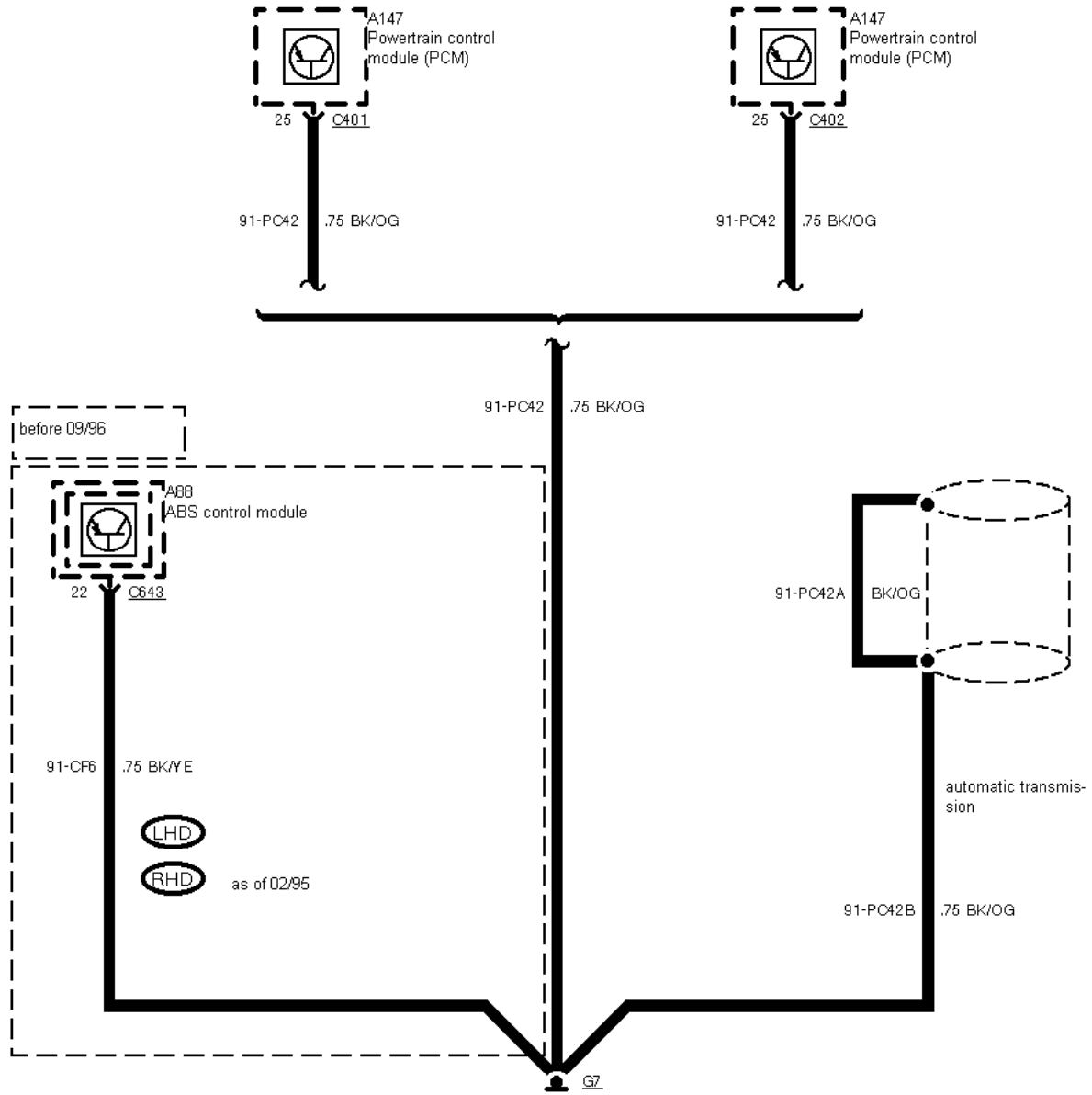

01-04-065 , Ground Distribution , Ground G7 As of 02/95 only 2,9 I V6

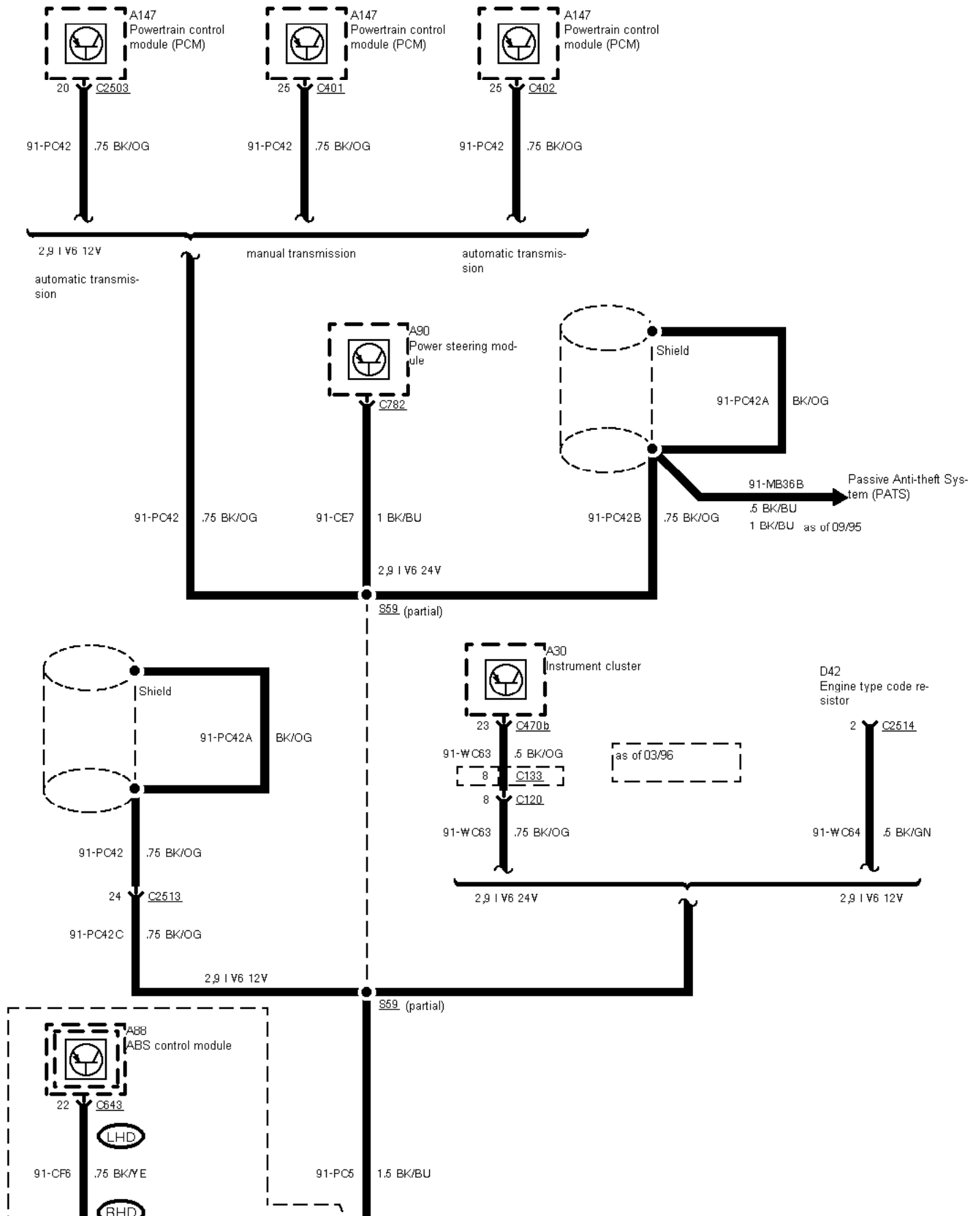

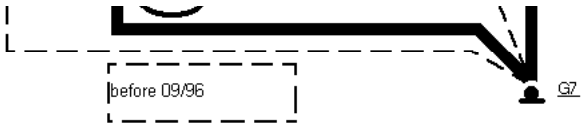

01-04-066 , Ground Distribution , Ground G7 Before 02/95

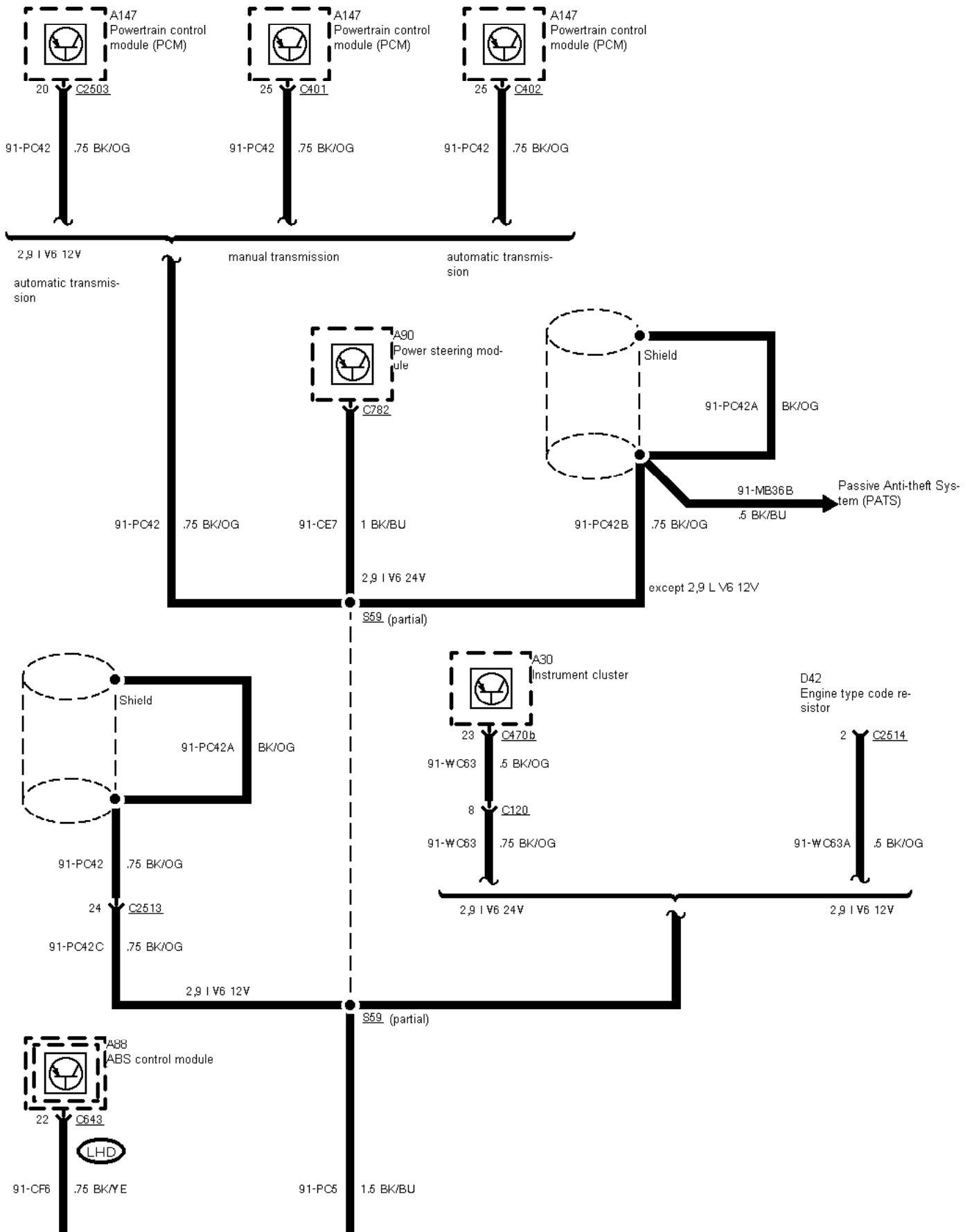



01-04-067 , Ground Distribution , Ground G7 TCI Diesel before 09/96

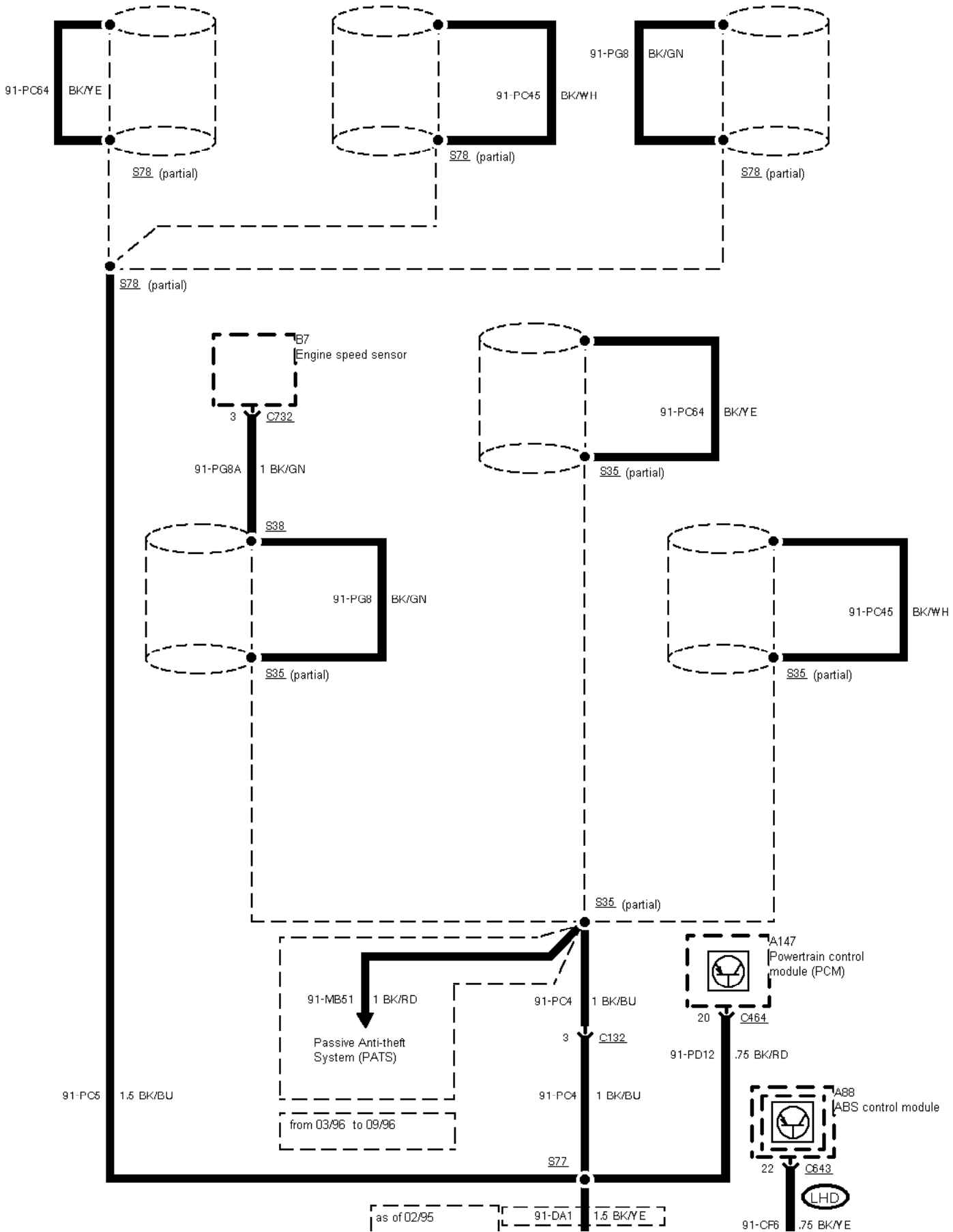

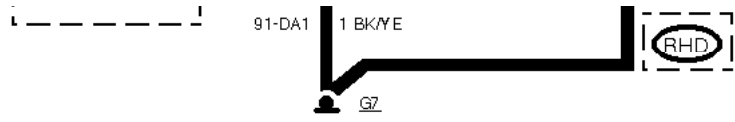

01-04-068 , Ground Distribution , Ground G8

As of 09/95

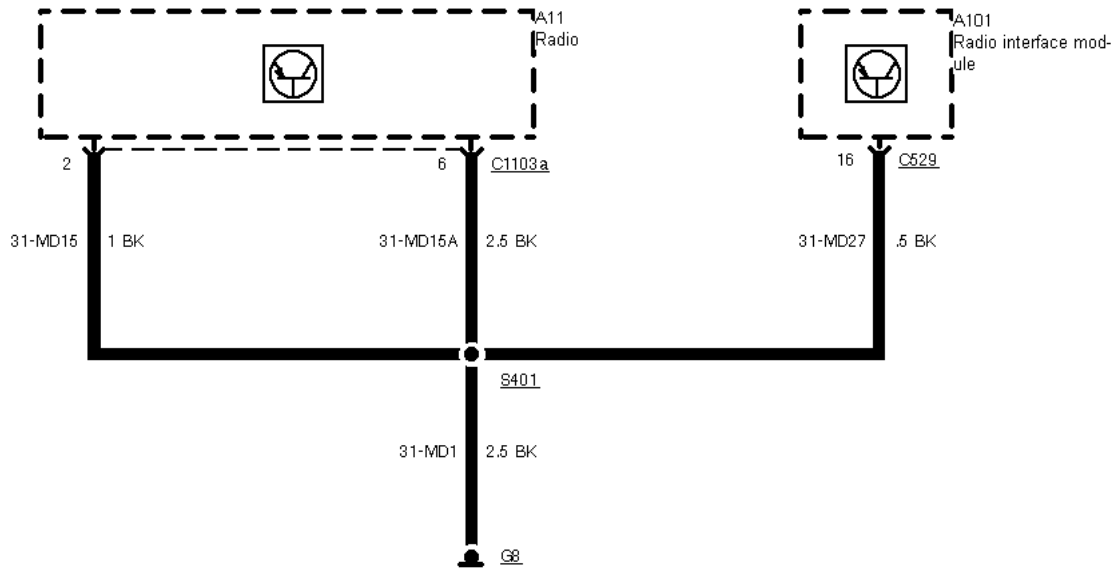

Taxi as of 09/95

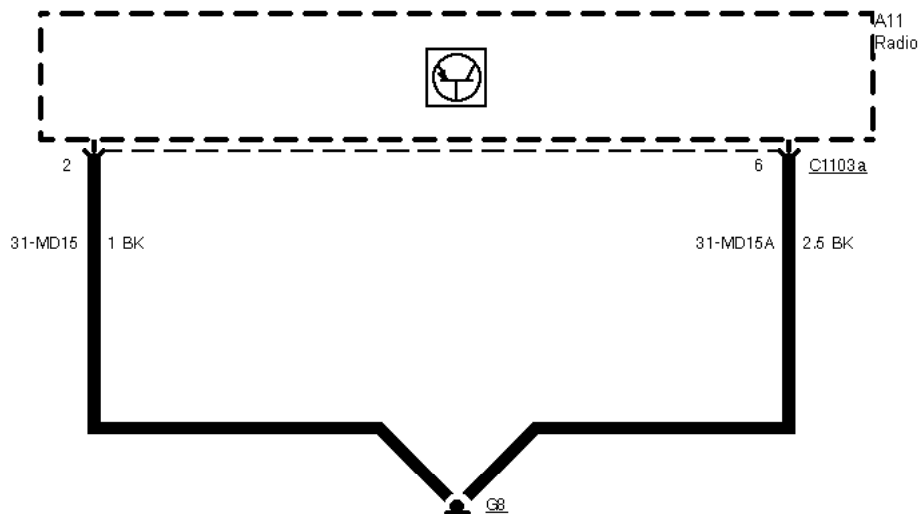

01-04-069 , Ground Distribution , Ground G8 Before 09/95

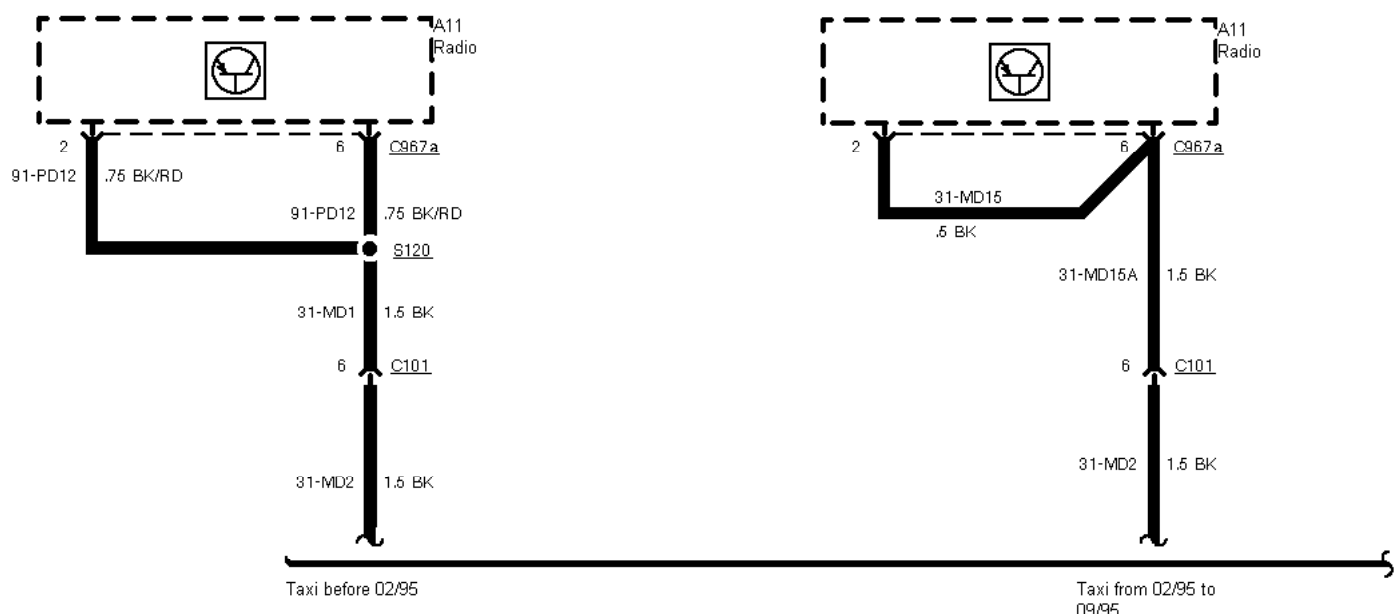
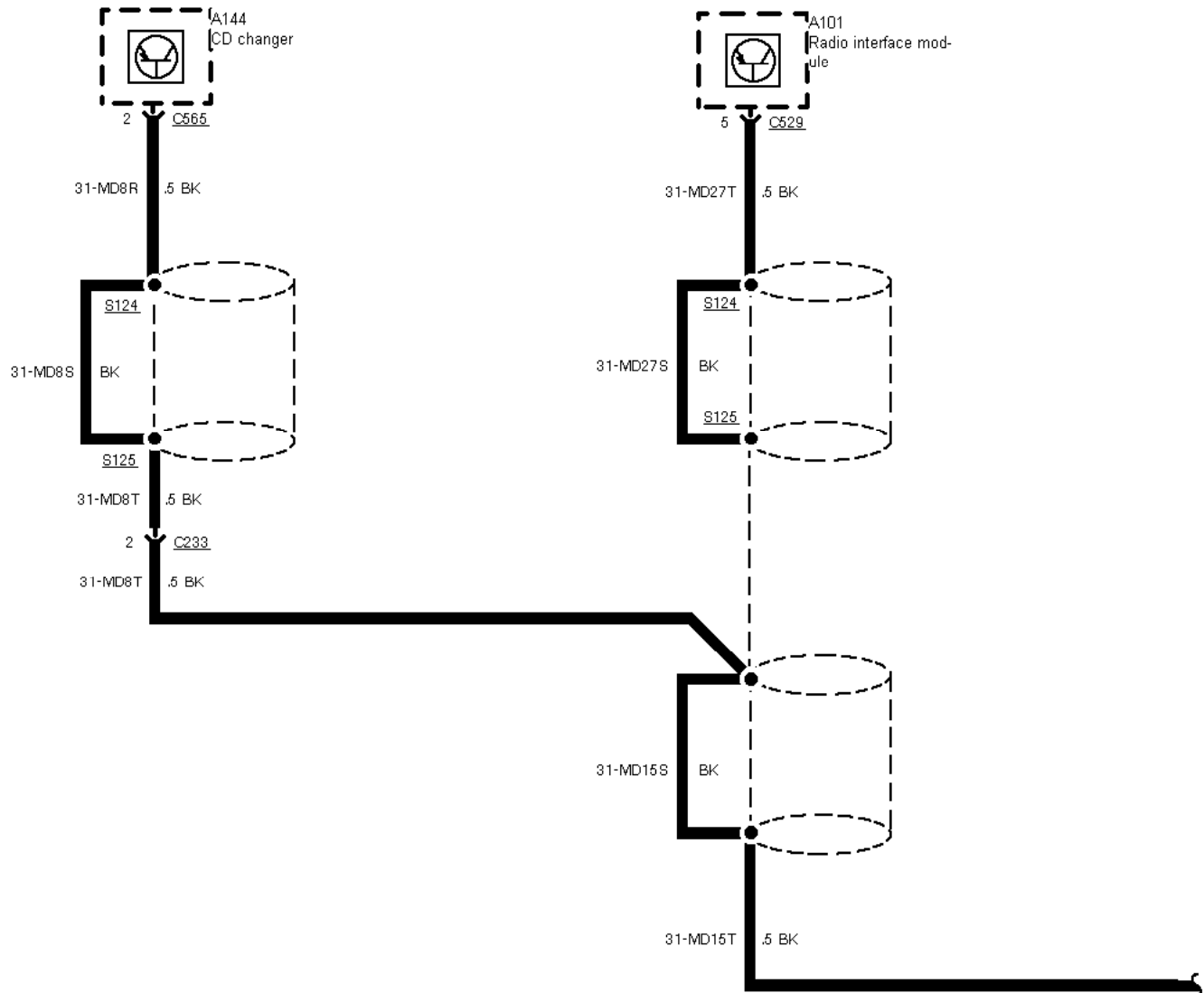

01-04-070 , Ground Distribution , Ground G8 Before 09/95

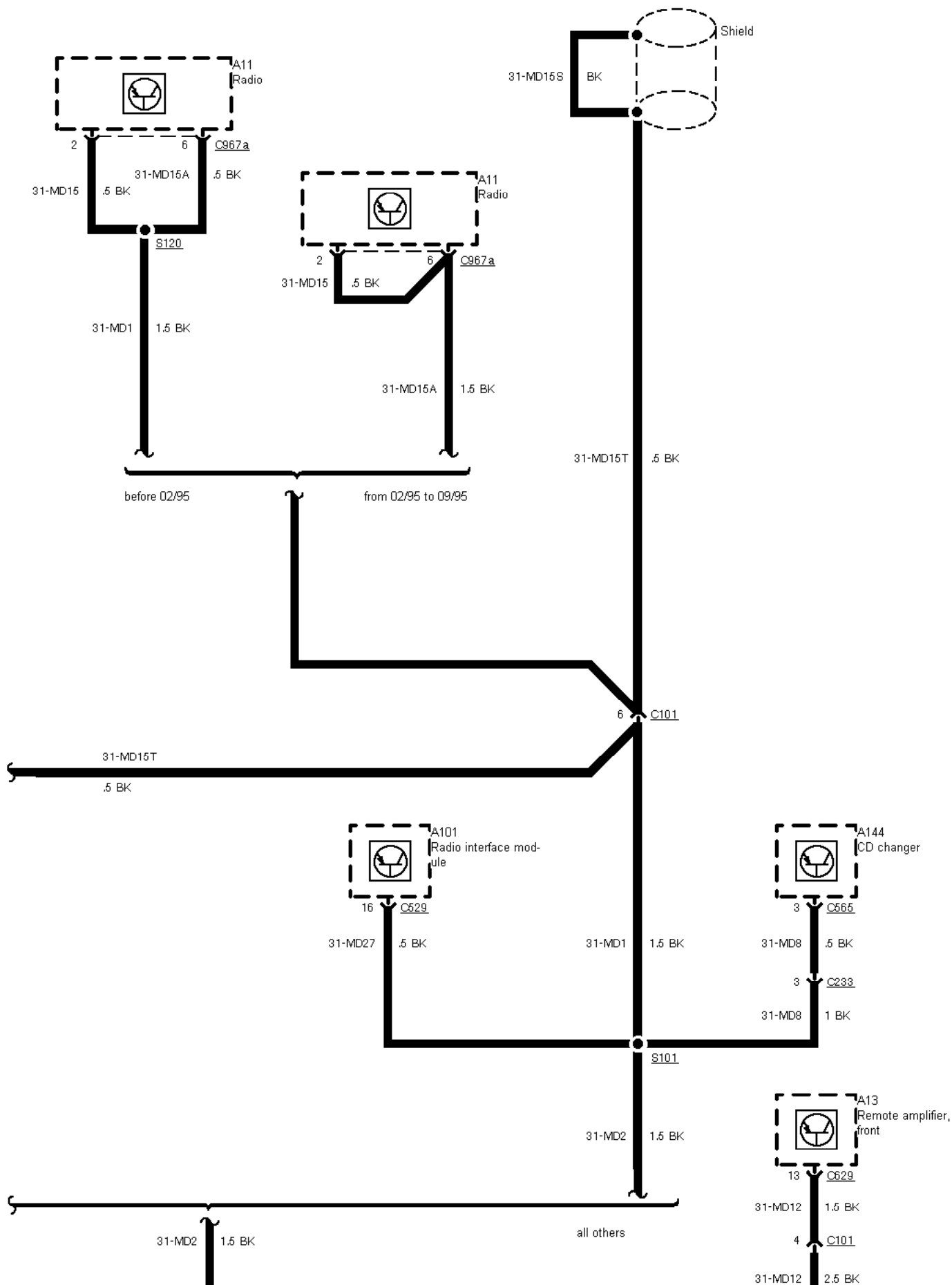

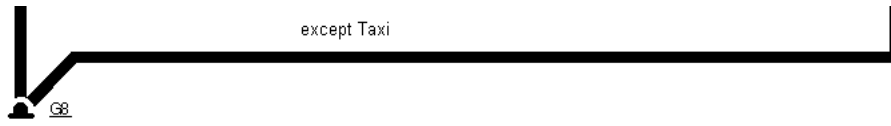

01-04-071 , Ground Distribution , Ground G9 Wagon

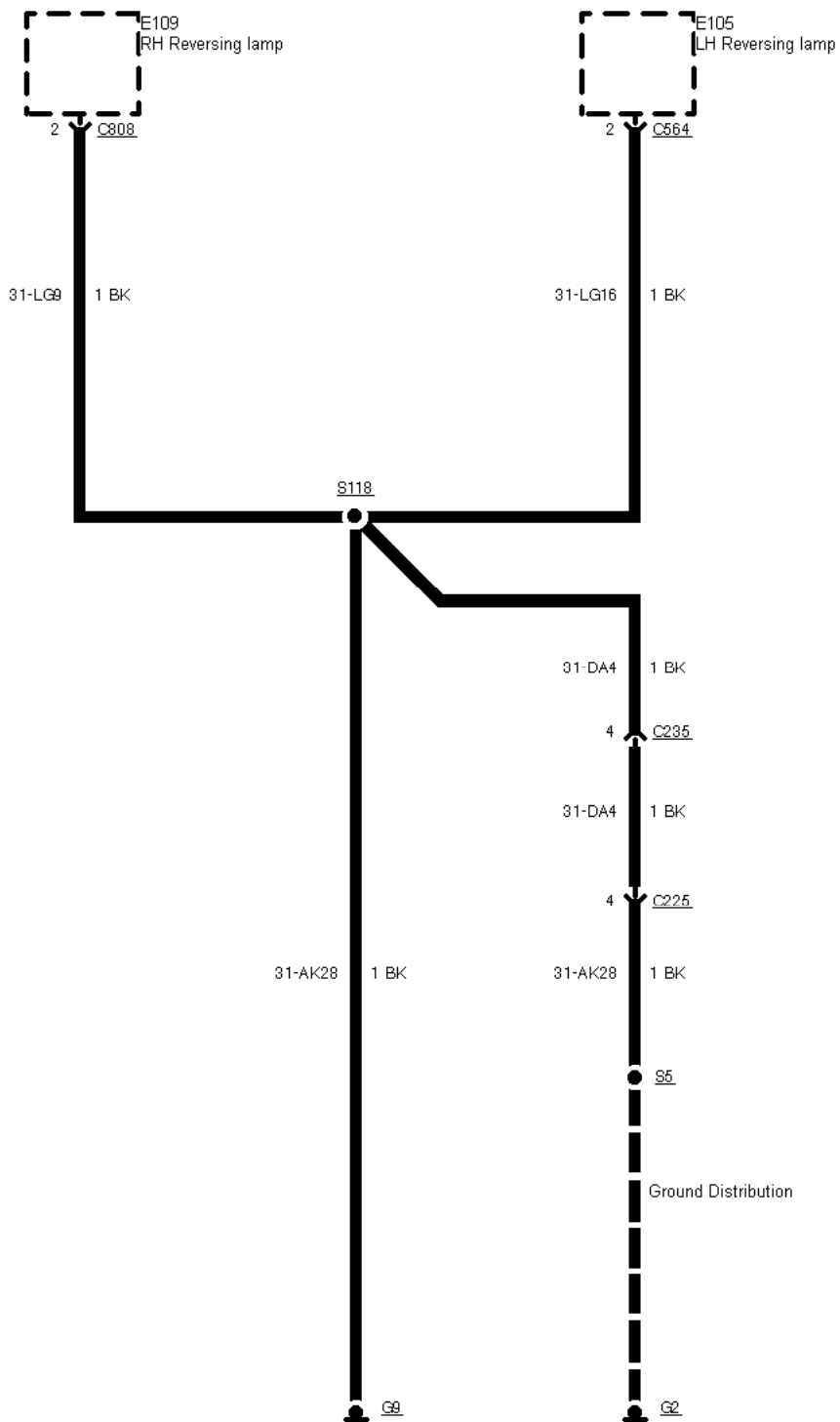

01-04-073 , Ground Distribution , Ground G10

Before 03/96 except TCI Diesel and 2,9 L V6 12V

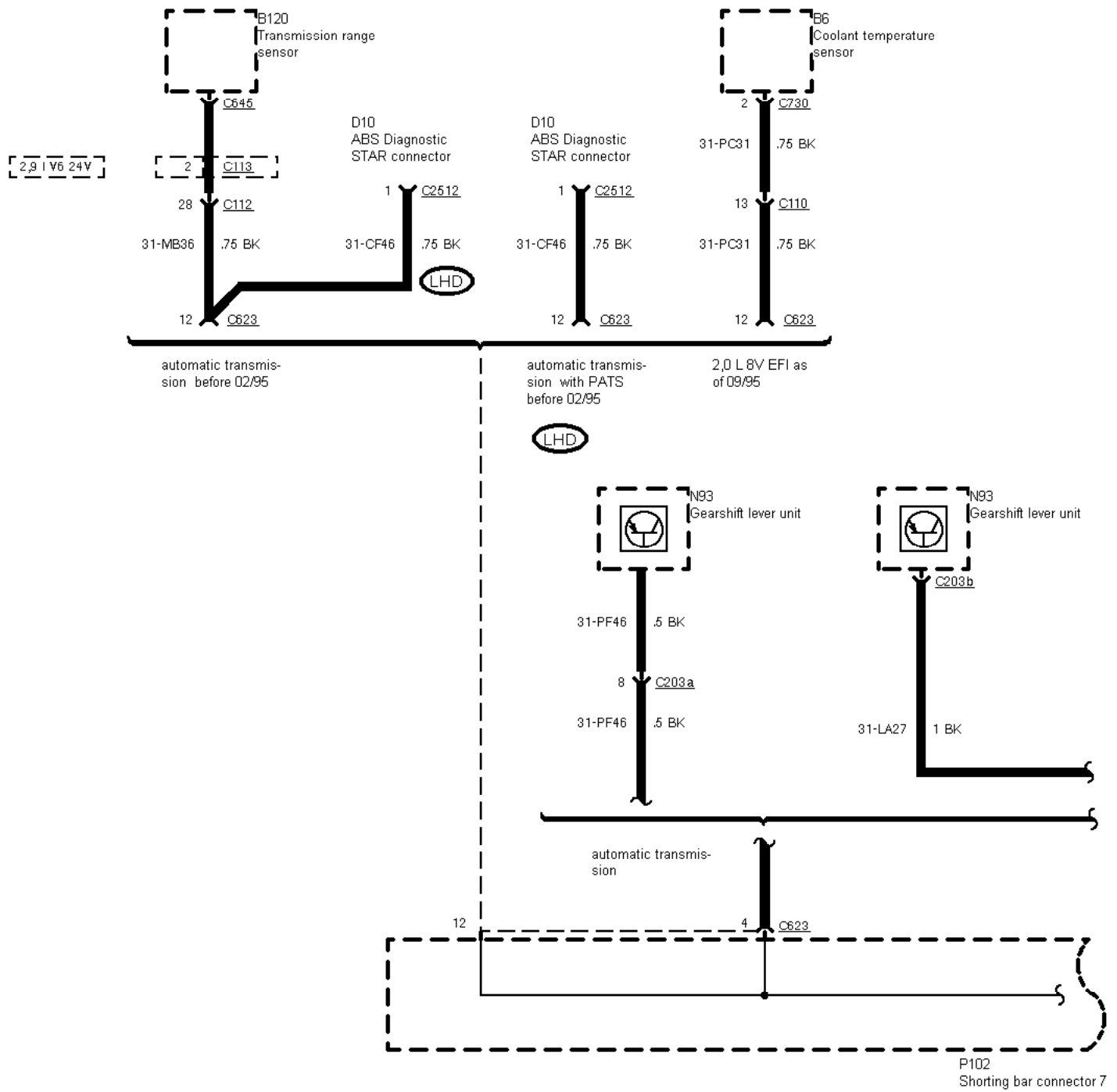

01-04-074 , Ground Distribution , Ground G10

Before 03/96 except TCI Diesel and 2,9 L V6 12V

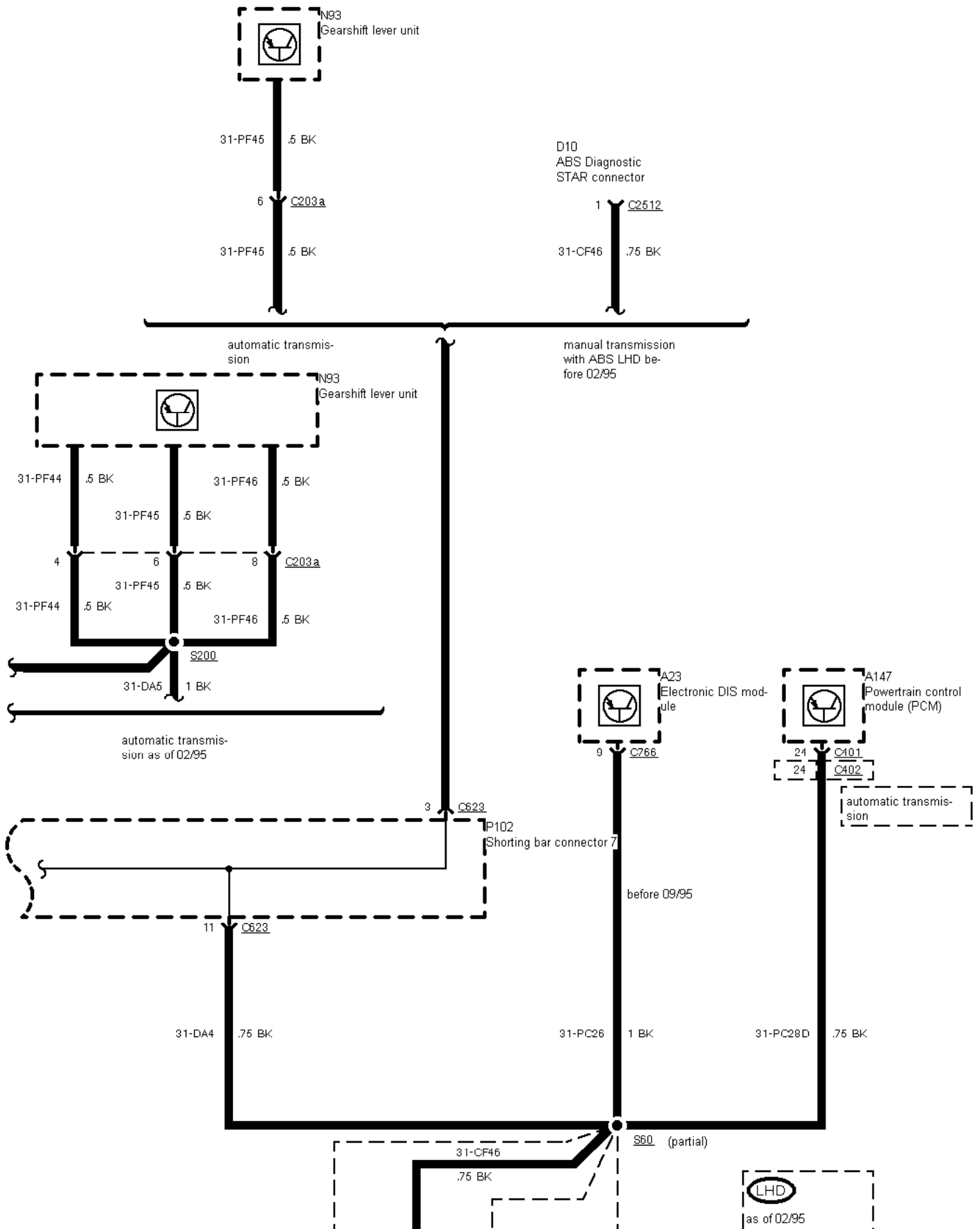

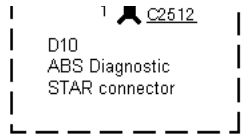

01-04-075 , Ground Distribution , Ground G10

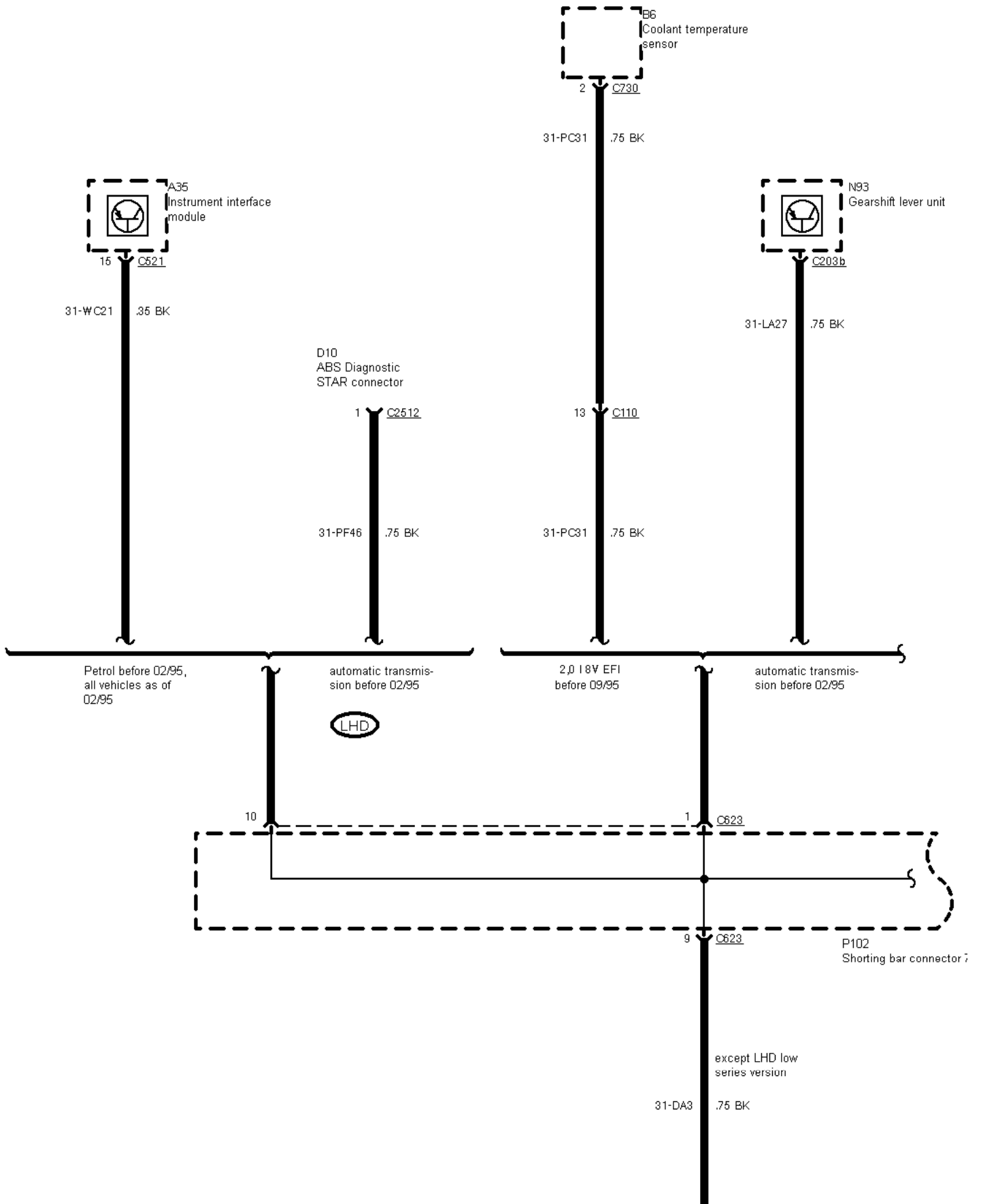



01-04-78

01-04-076 , Ground Distribution , Ground G10

Before 03/96 except TCI Diesel and 2,9 L V6 12V

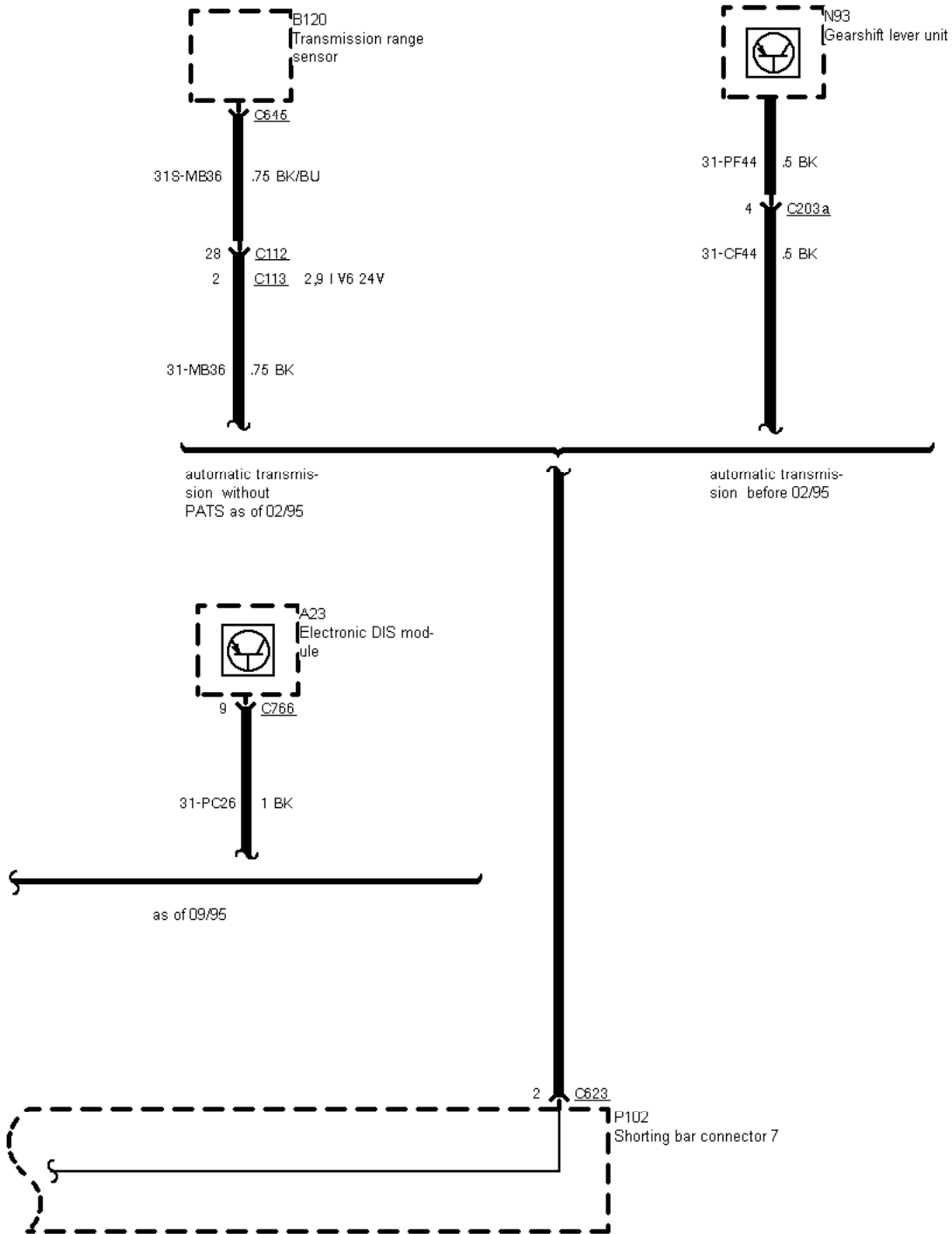

01-04-077 , Ground Distribution , Ground G10

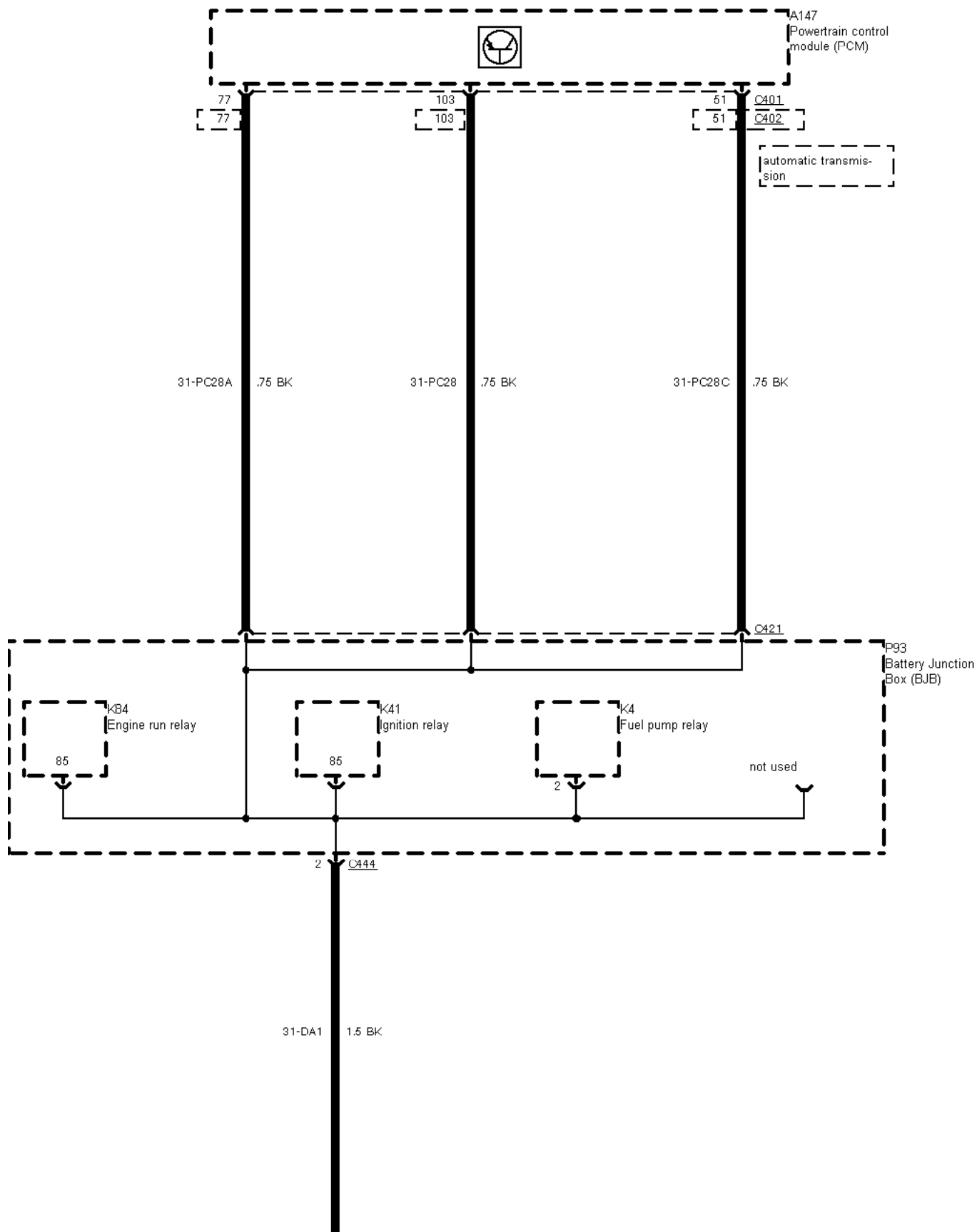



01-04-078 , Ground Distribution , Ground G10

Before 03/96 except TCI Diesel and 2,9 L V6 12V

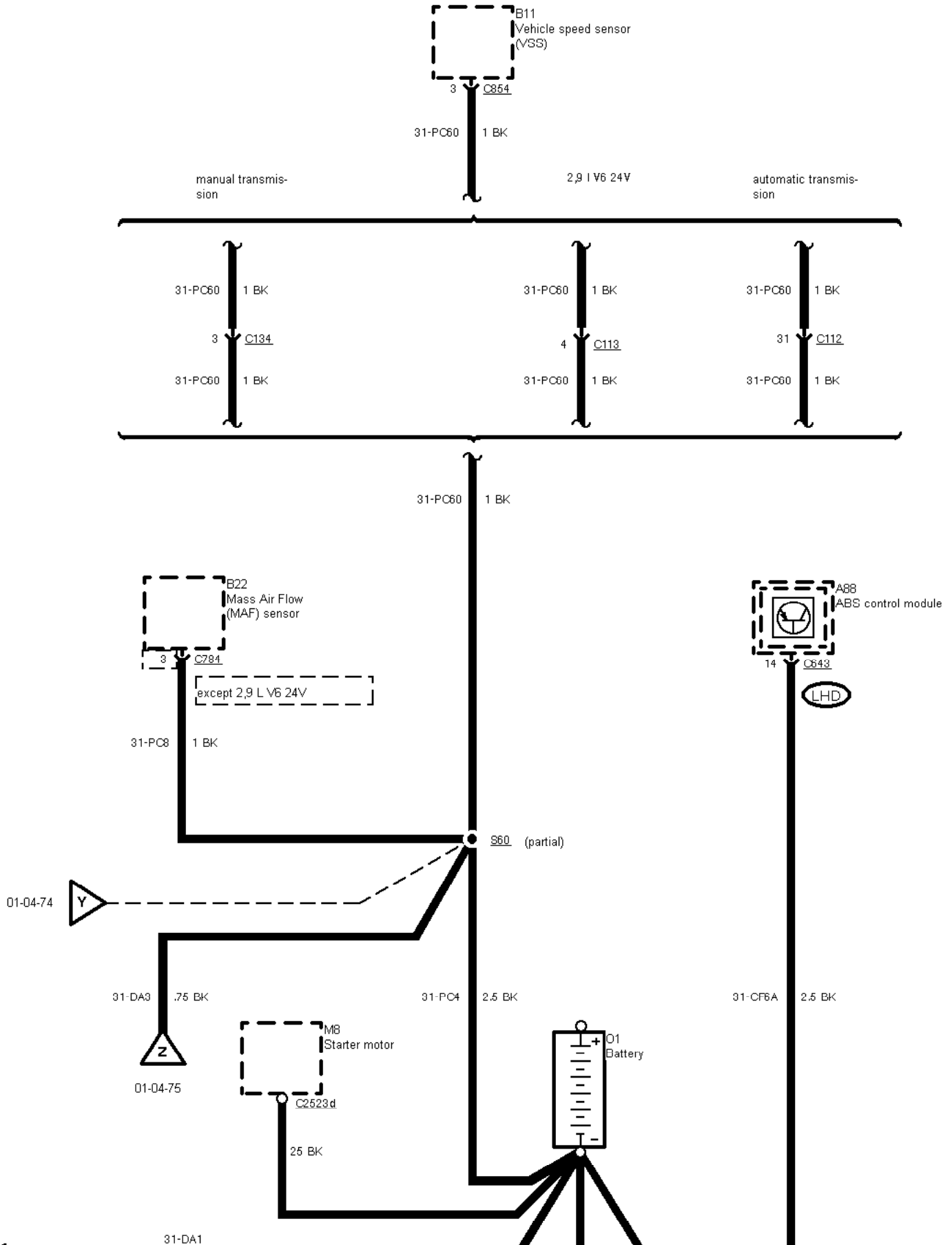



1.5 BK



10 BK

G10

01-04-079 , Ground Distribution , Ground G10

As of 03/96 except TCI Diesel and 2,9 L V6 12V

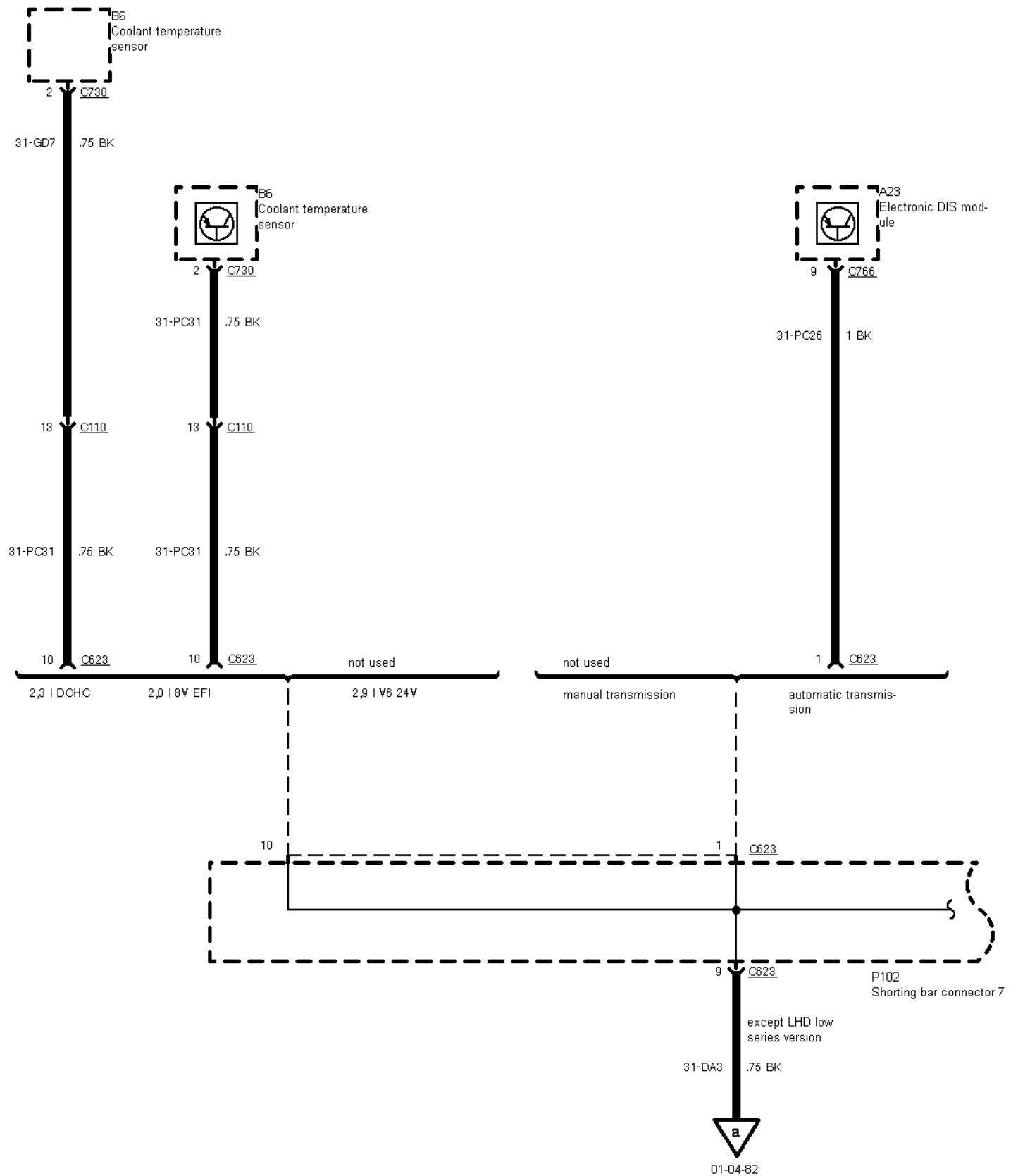

01-04-080 , Ground Distribution , Ground G10

As of 03/96 except TCI Diesel and 2.9 L V6 12V

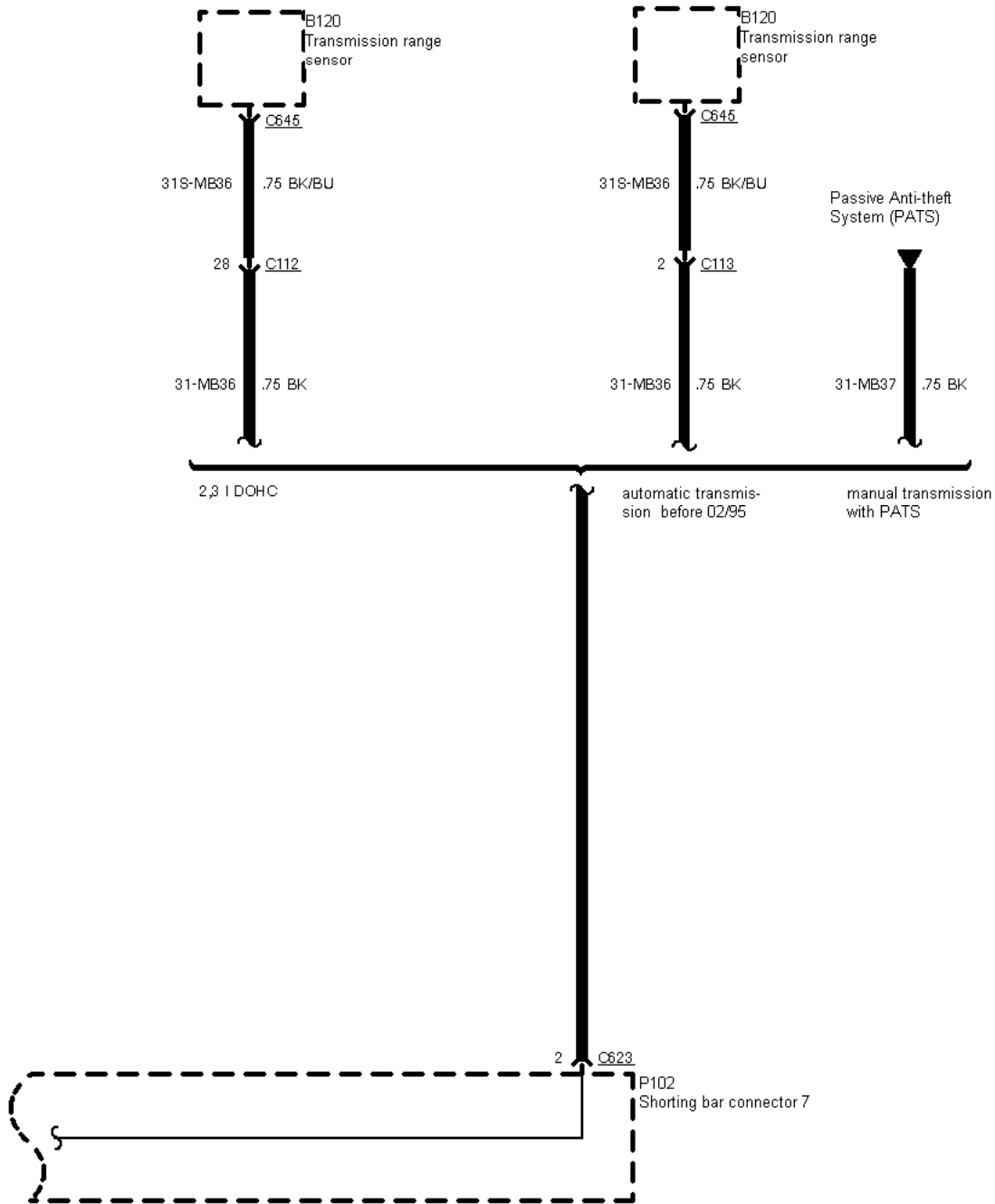

01-04-081 , Ground Distribution , Ground G10

As of 03/96 except TCI Diesel and 2.9 L V6 12V

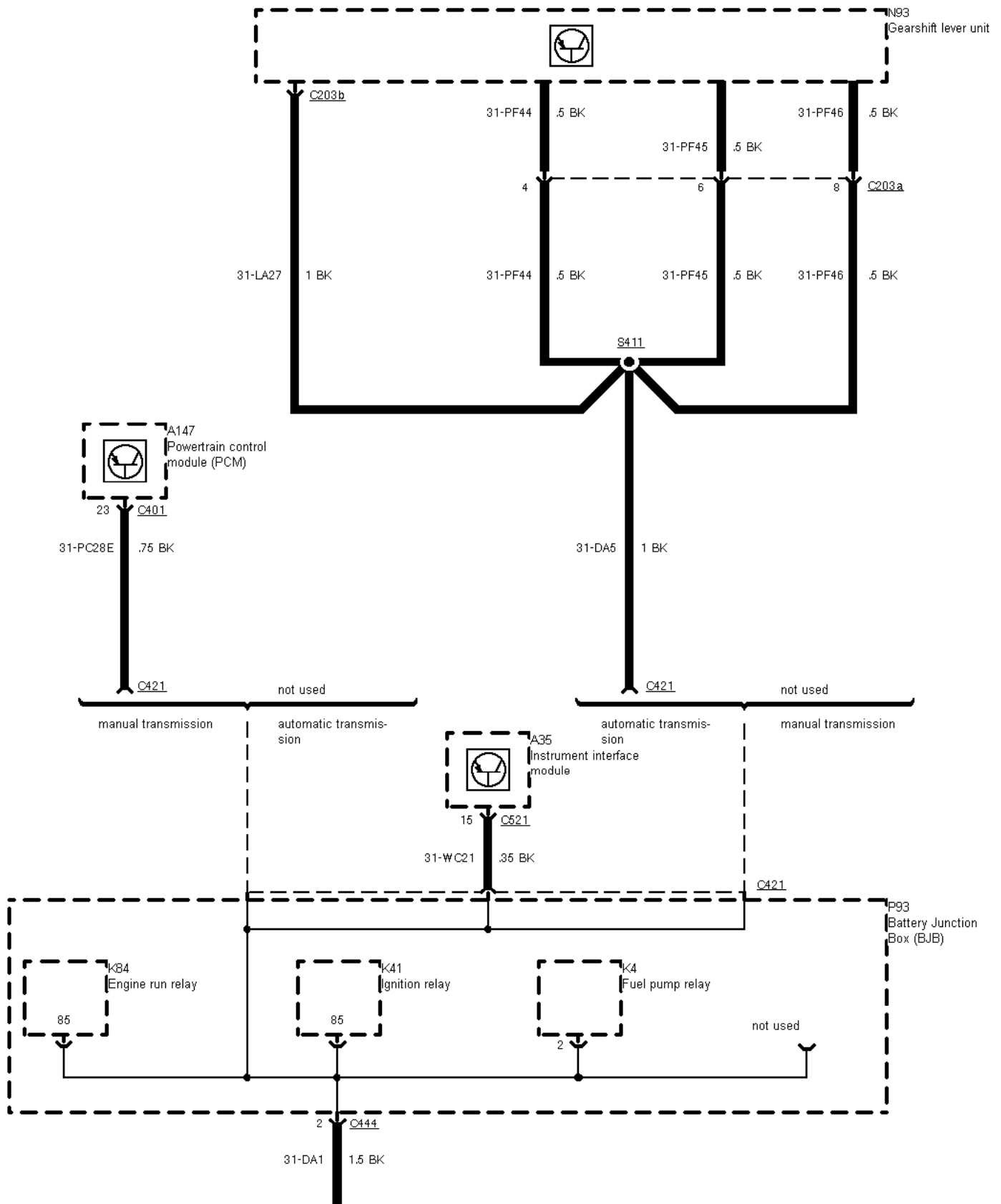



01-04-082 , Ground Distribution , Ground G10

As of 03/96 except TCI Diesel and 2,9 L V6 12V

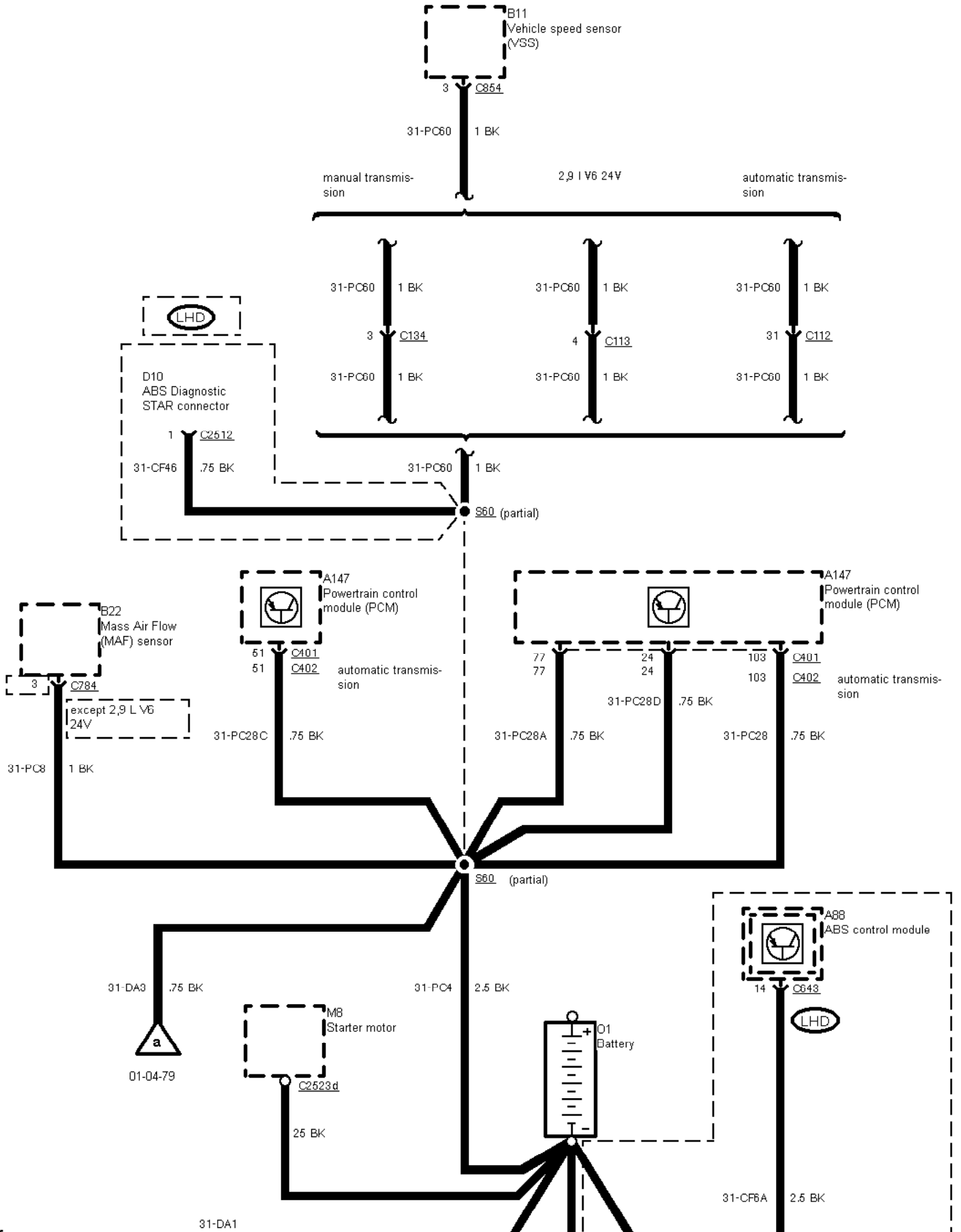



1.5 BK

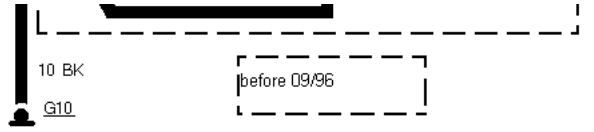

01-04-083 , Ground Distribution , Ground G10, 2,9 I V6 12V

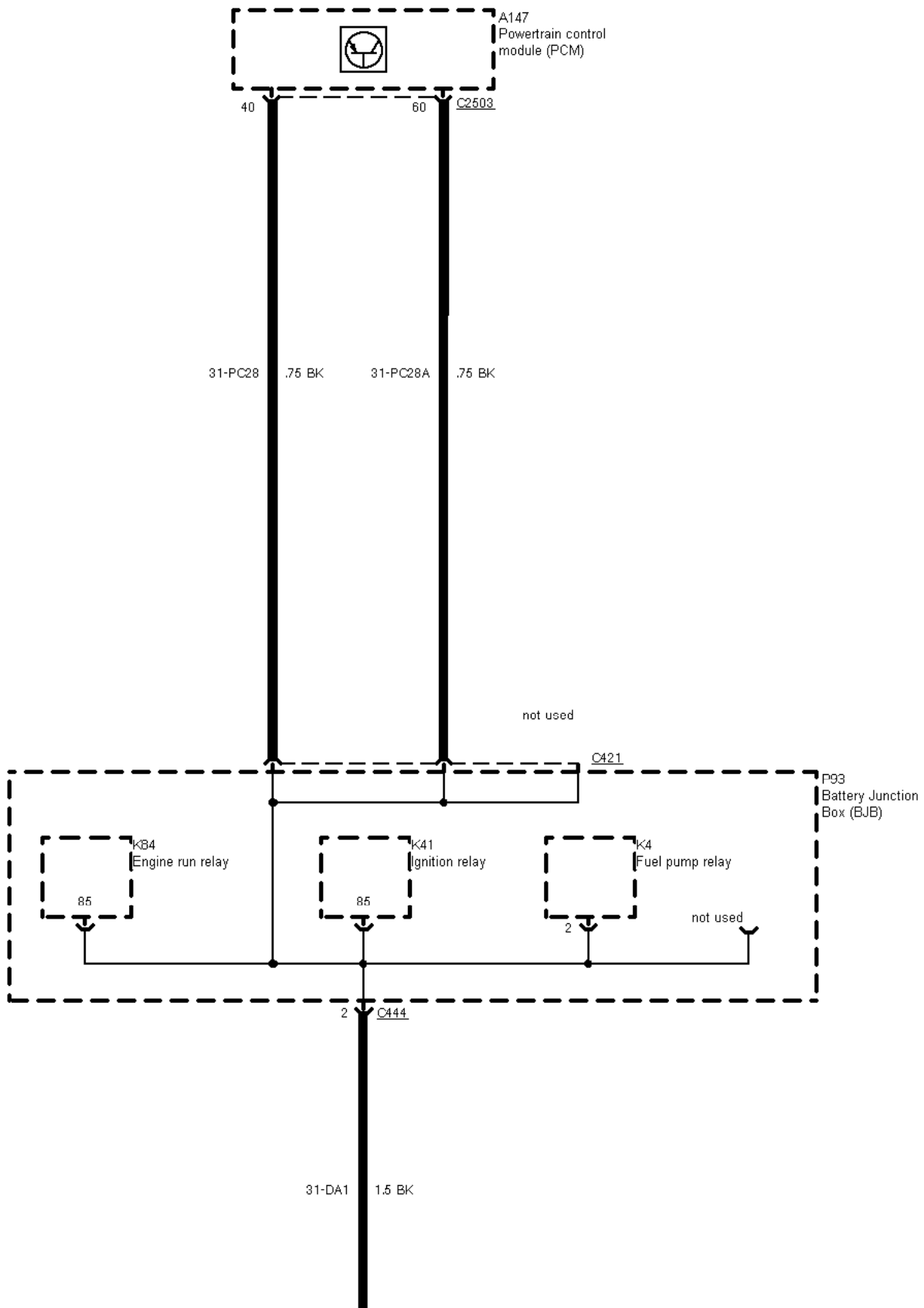

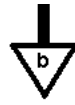

01-04-86

01-04-084 , Ground Distribution , Ground G10, 2,9 I V6 12V

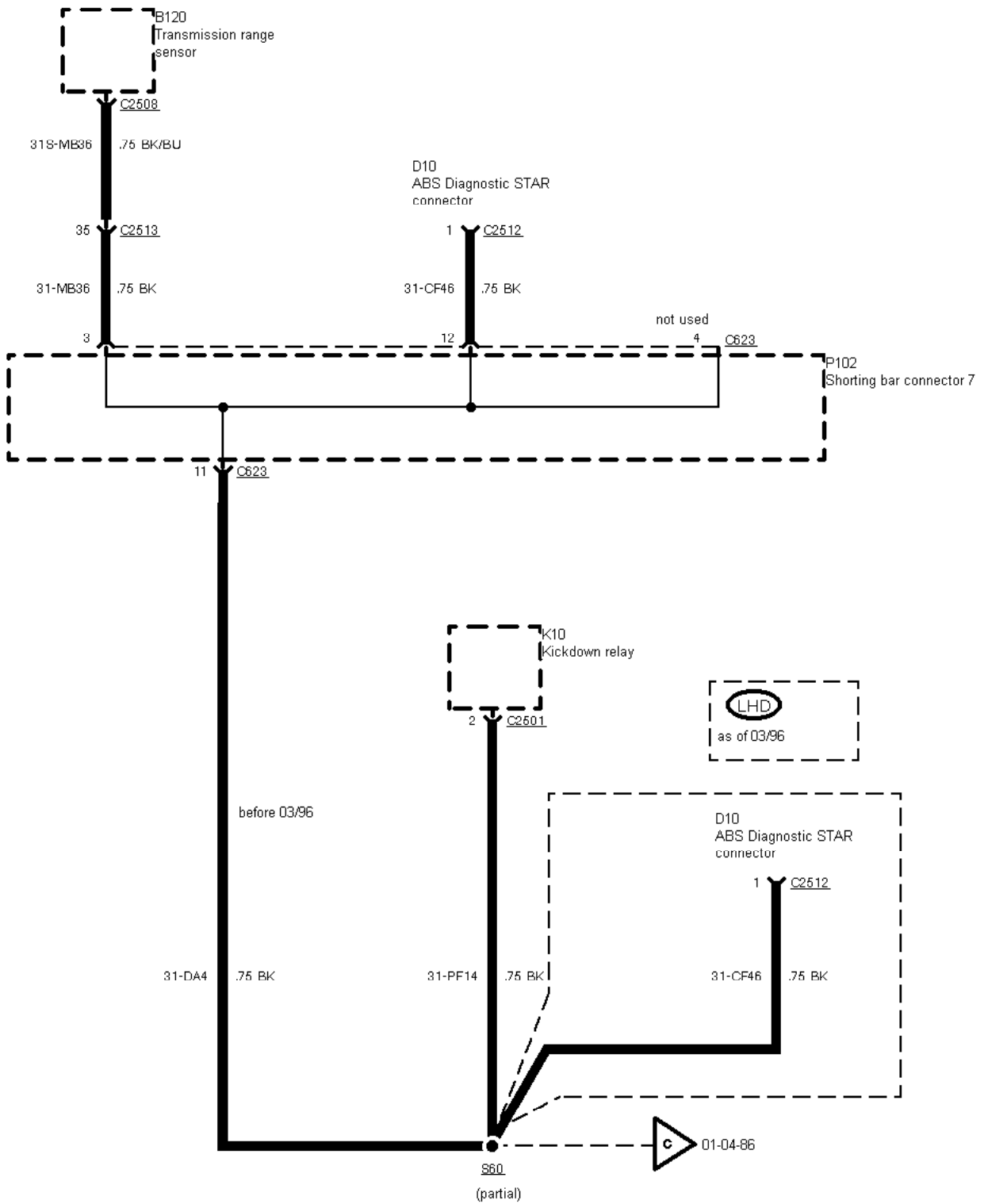

01-04-085 , Ground Distribution , Ground G10, 2,9 I V6 12V

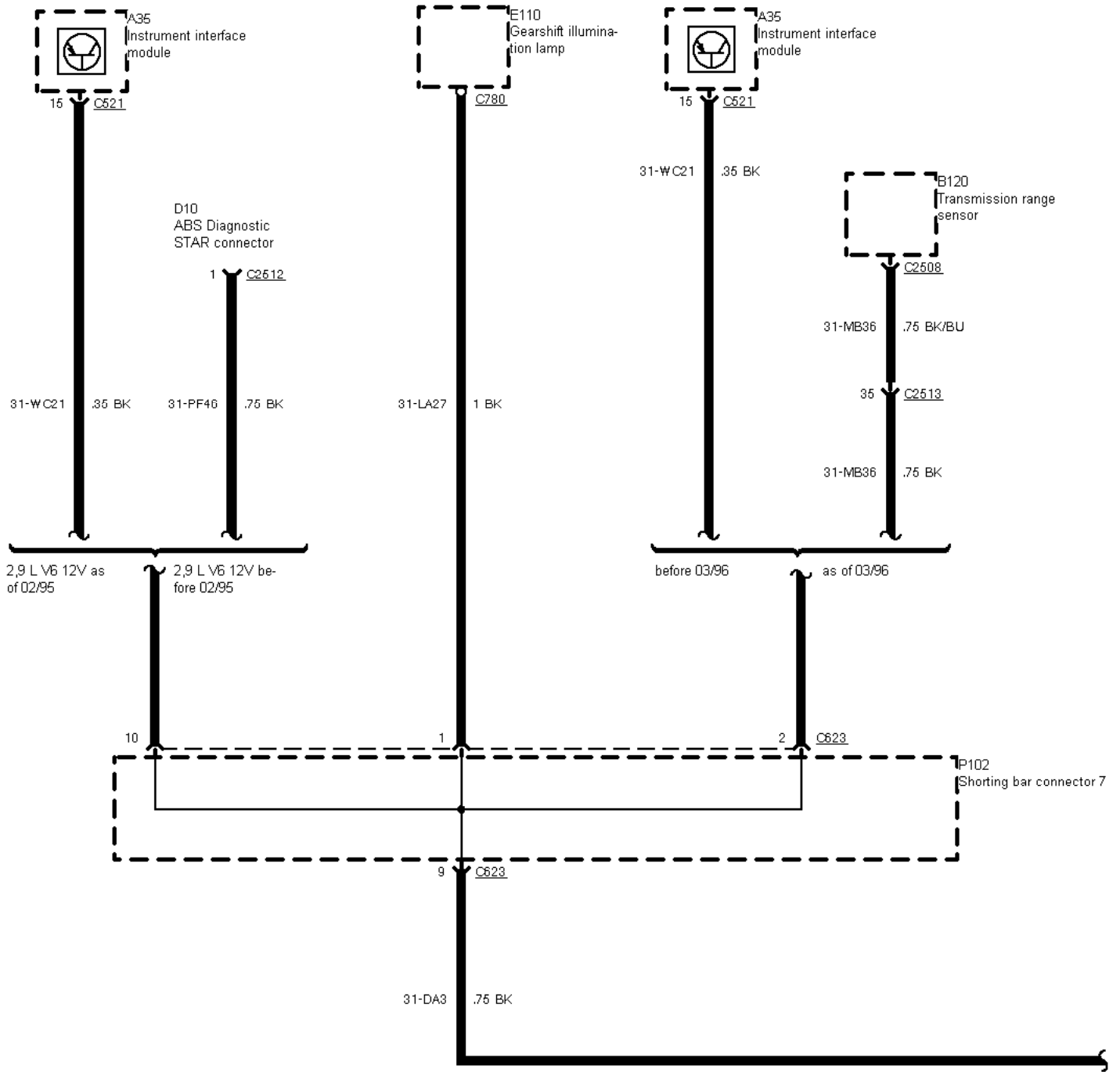

01-04-086 , Ground Distribution , Ground G10, 2,9 l V6 12V

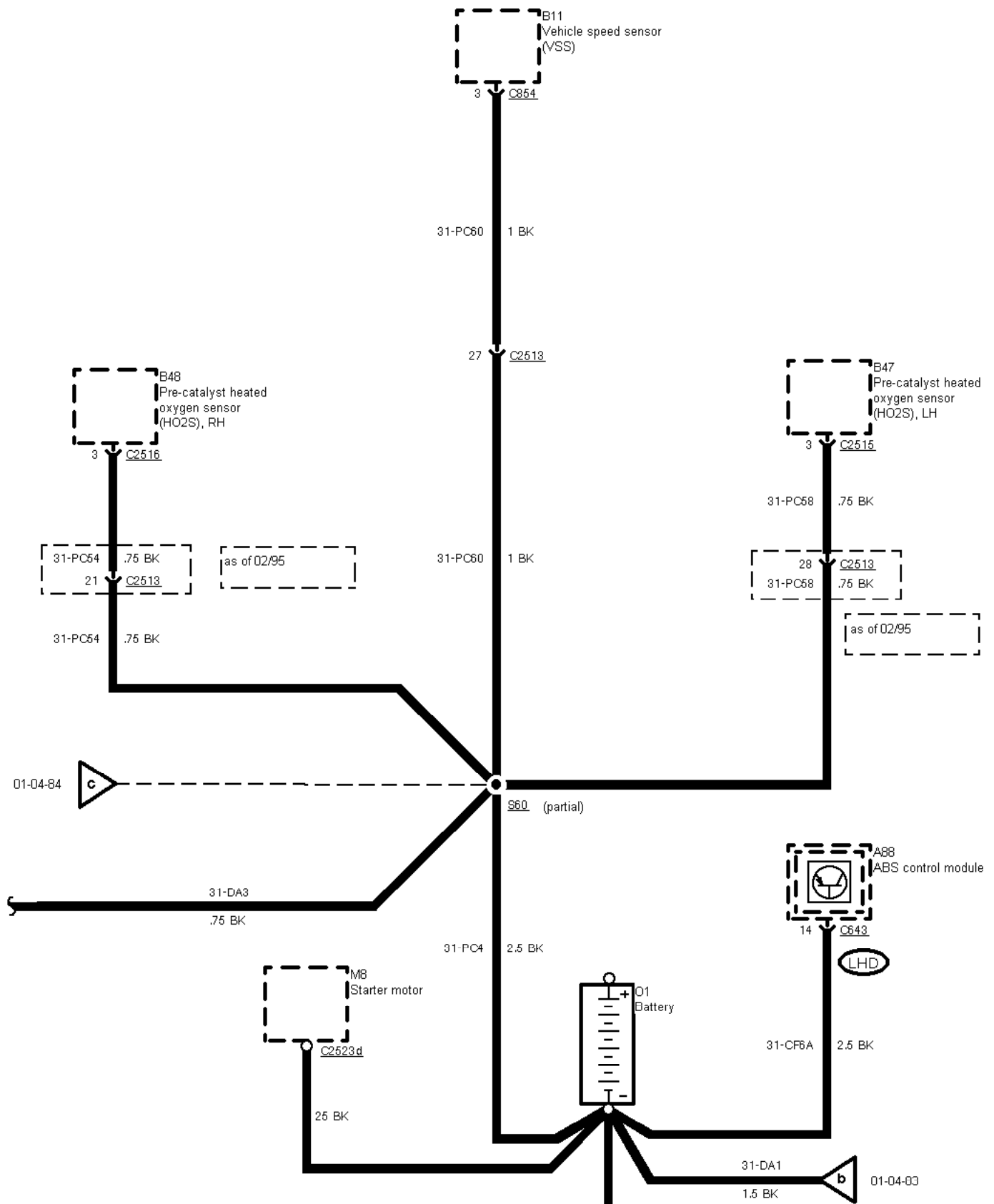

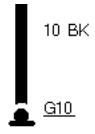

01-04-087 , Ground Distribution , Ground G10 TCI Diesel before 09/96

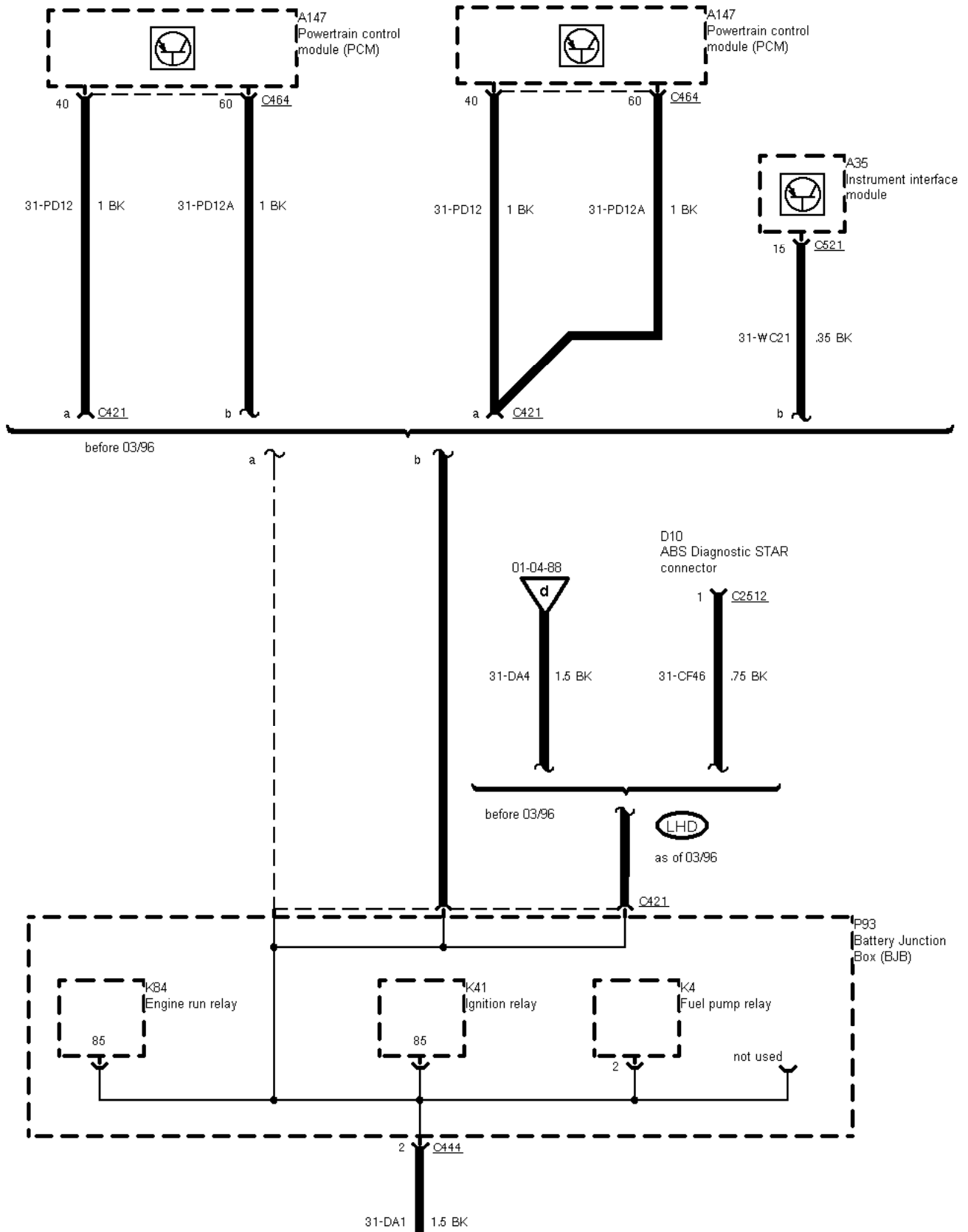



01-04-89

01-04-088 , Ground Distribution , Ground G10

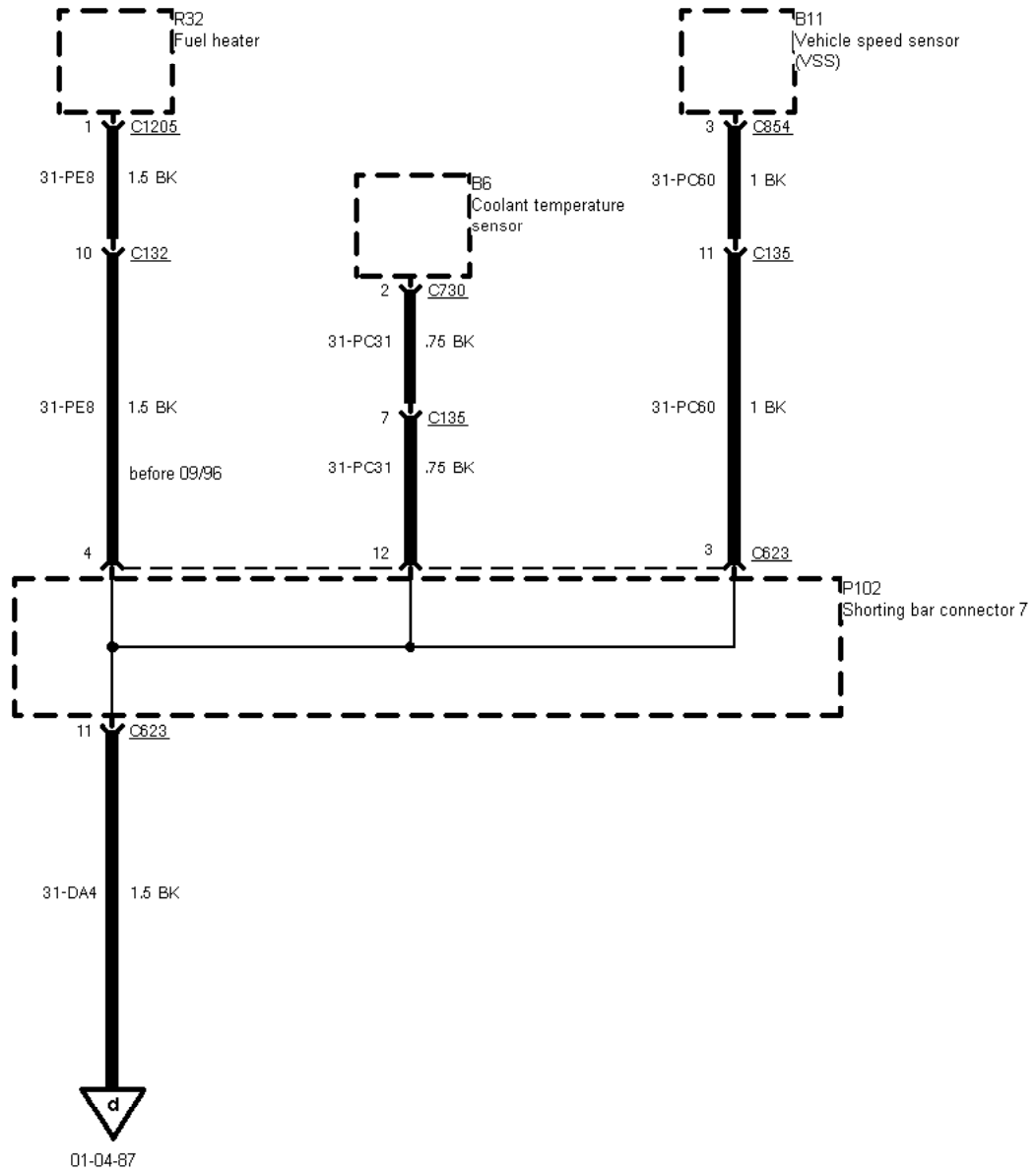

01-04-089 , Ground Distribution , Ground G10

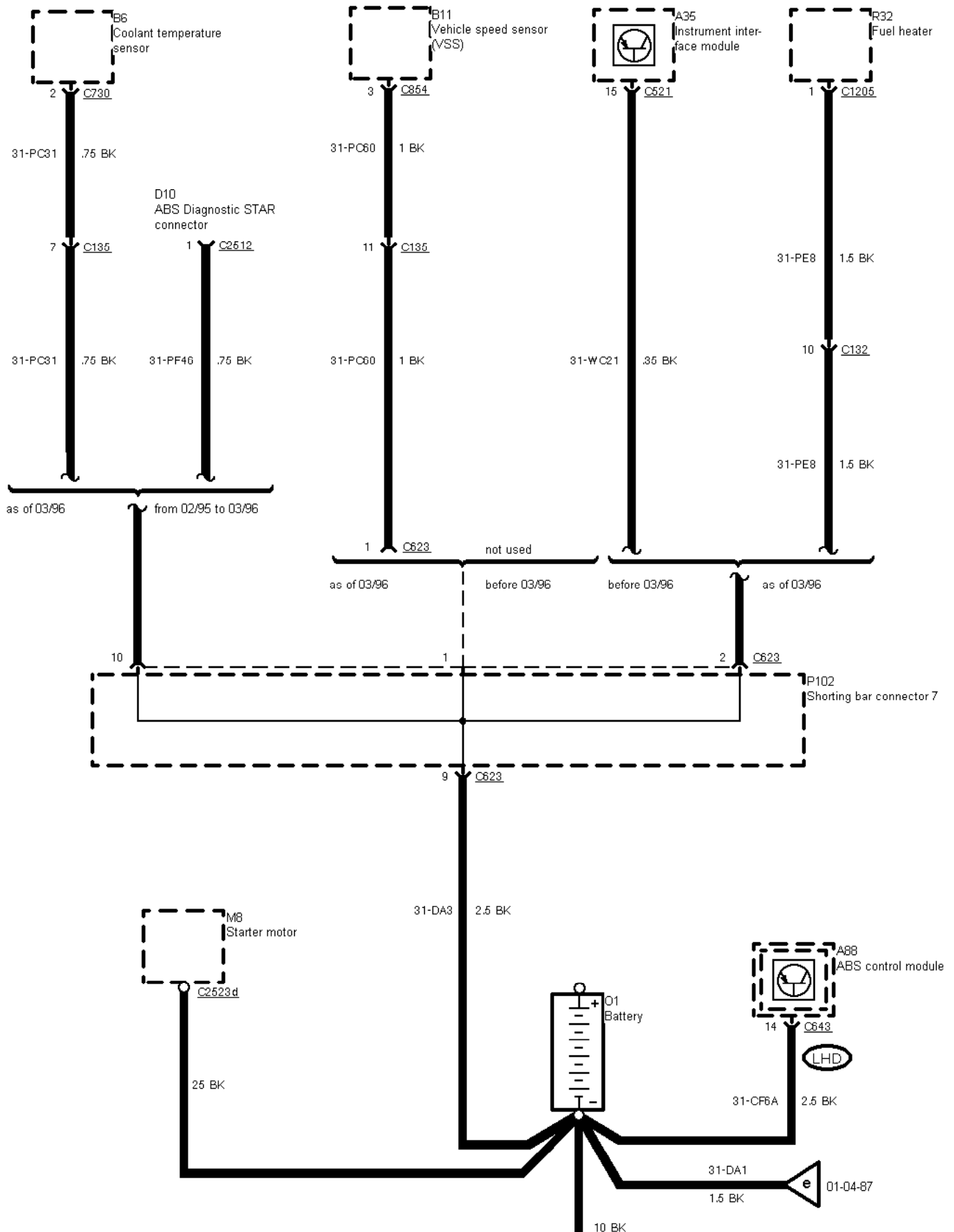



G10

01-04-090 , Ground Distribution , Ground G10

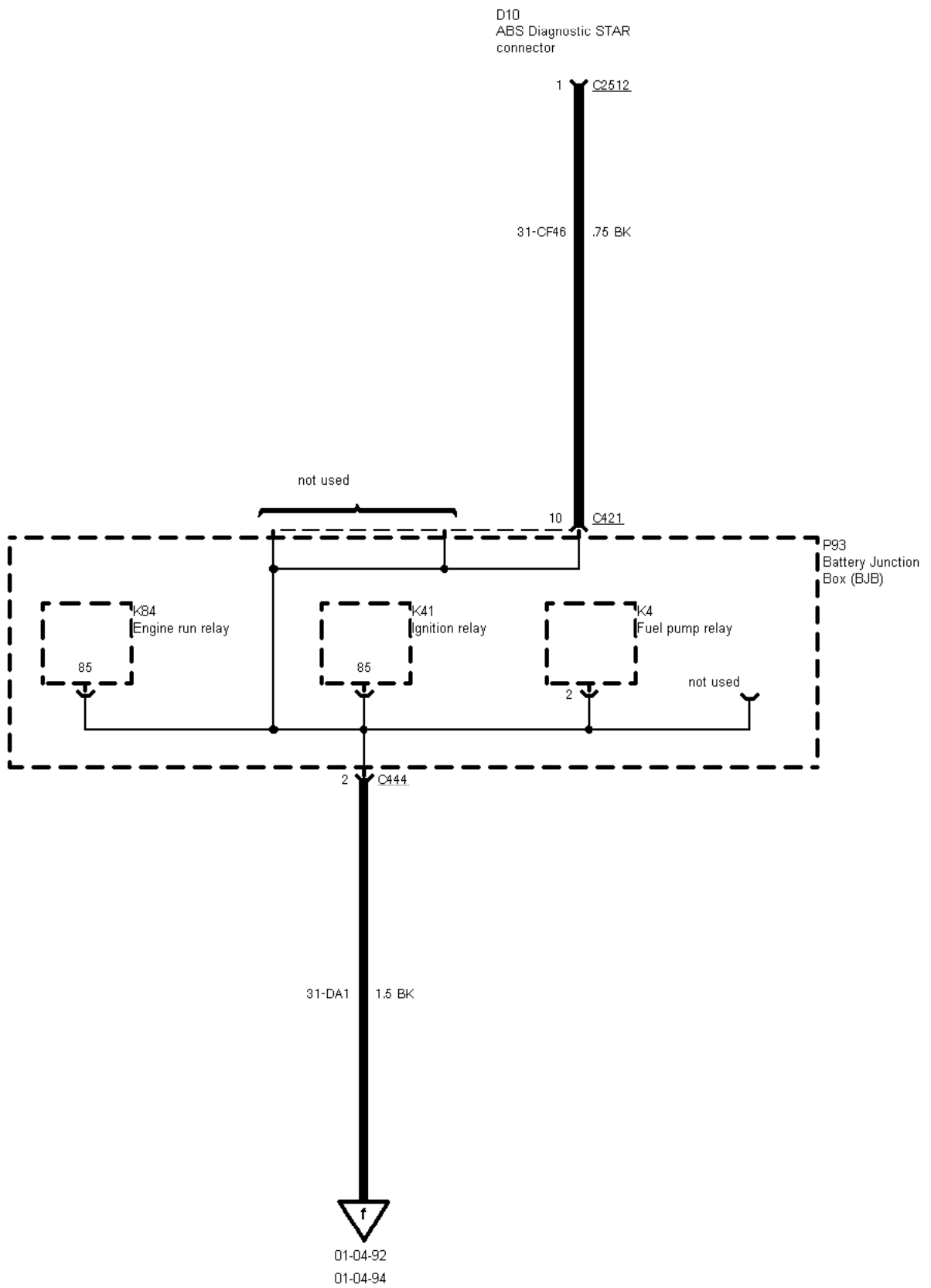

01-04-091 , Ground Distribution , Ground G10

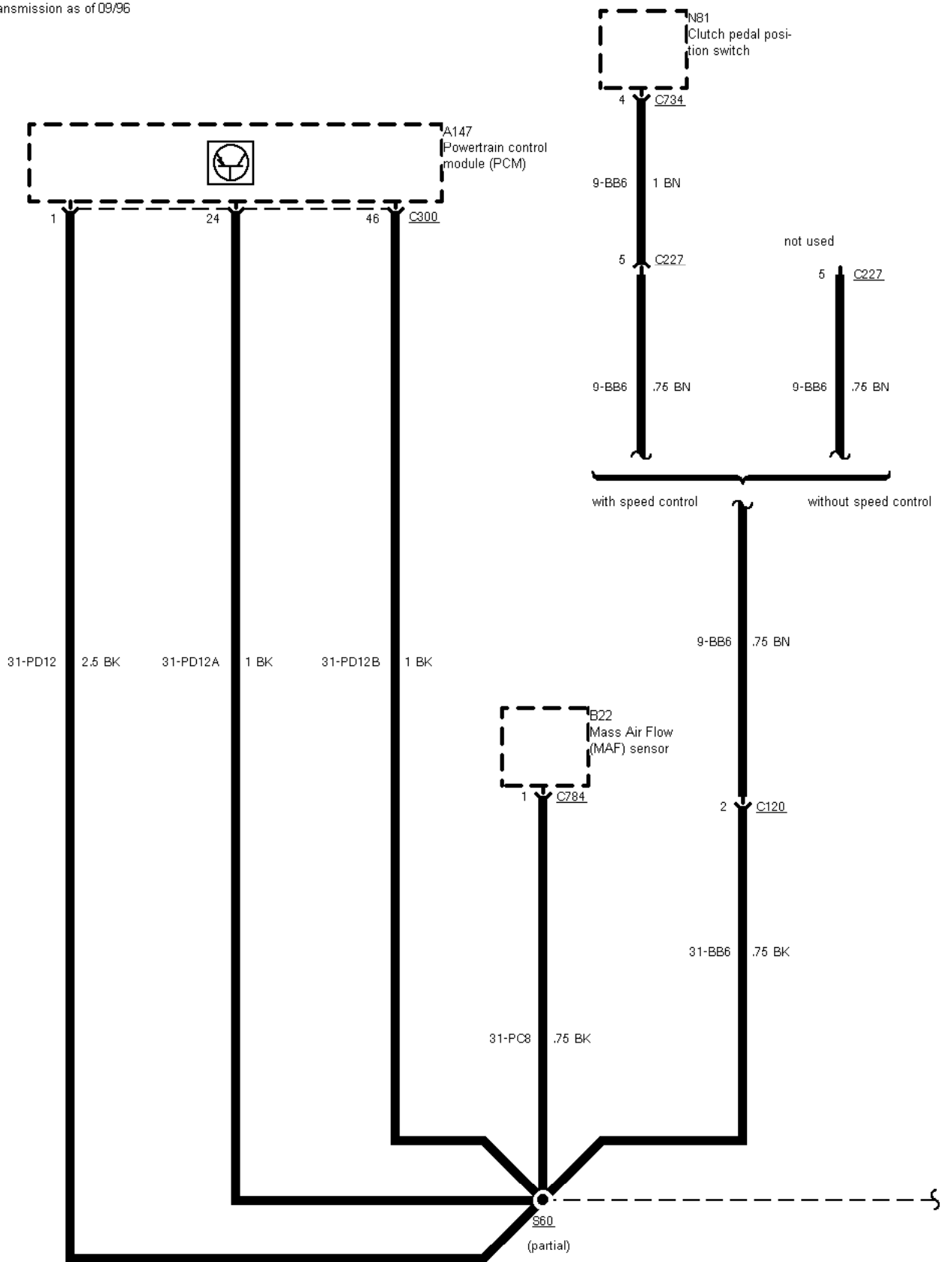

01-04-092 , Ground Distribution , Ground G10



01-04-093 , Ground Distribution , Ground G10

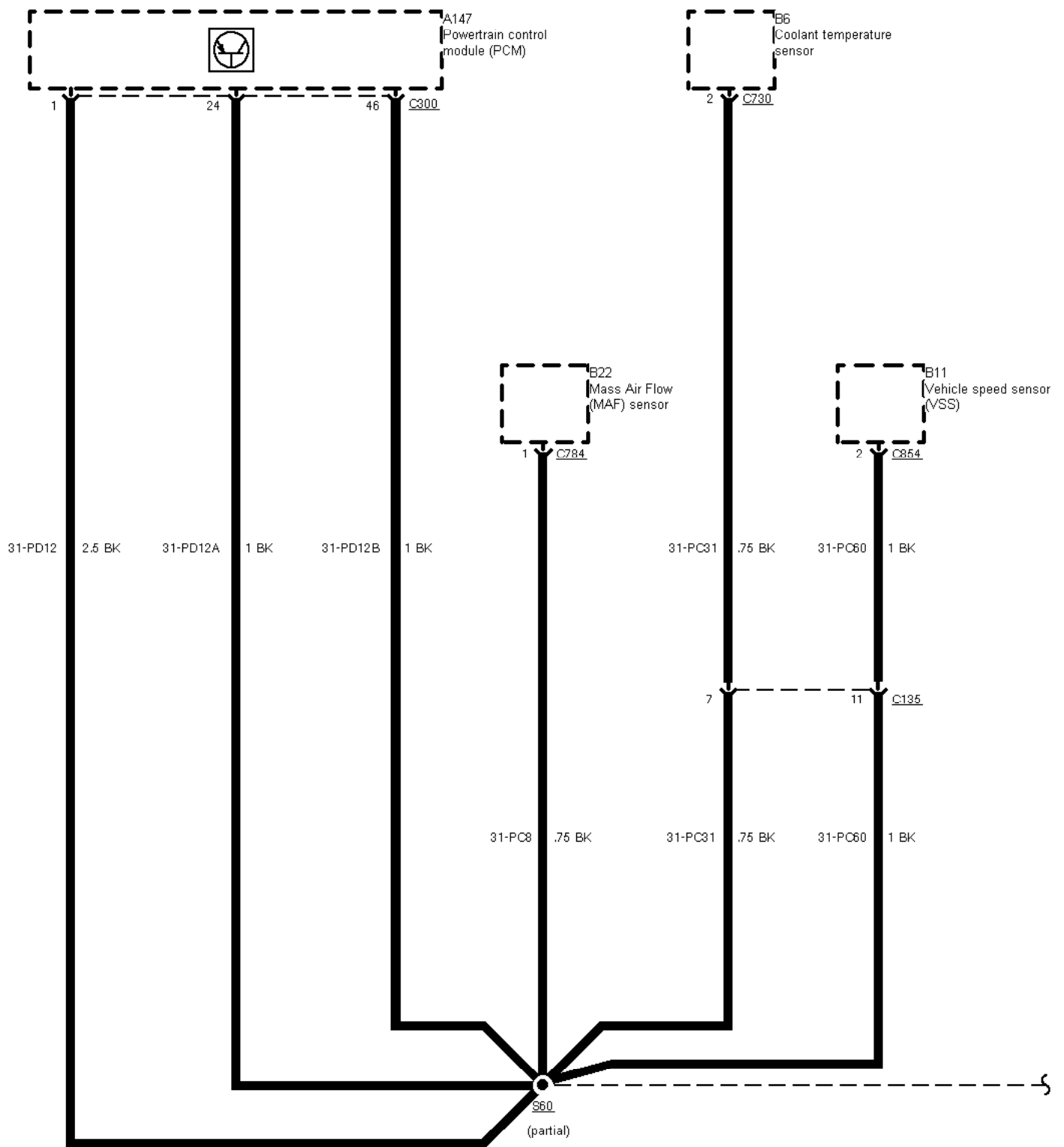

01-04-094 , Ground Distribution , Ground G10

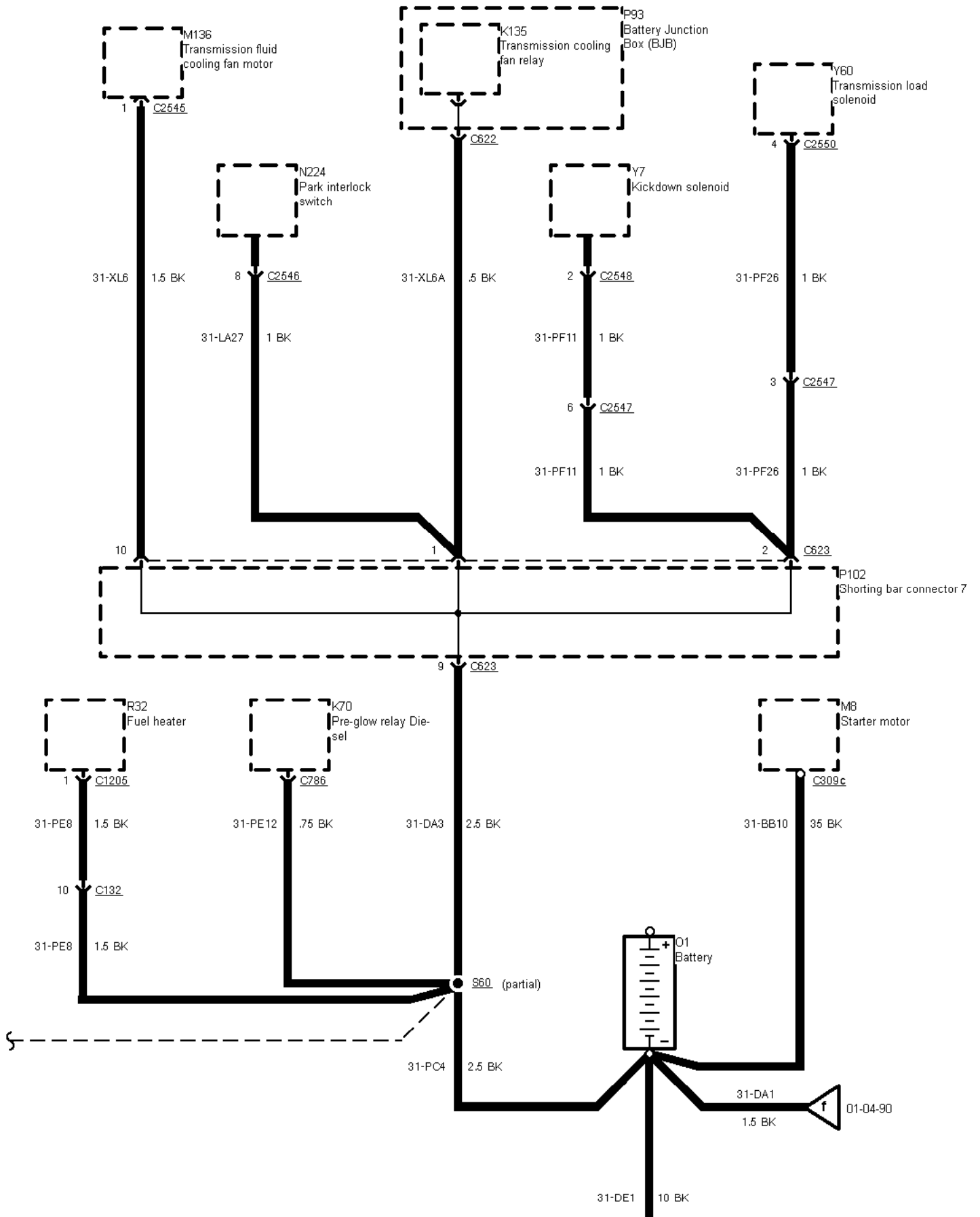



01-04-095 , Ground Distribution

Ground G11

2,9 L V6 12V automatic transmission

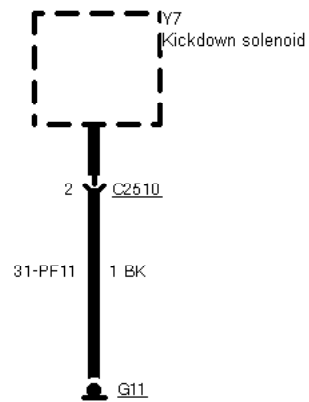

Ground G12 with trailer socket

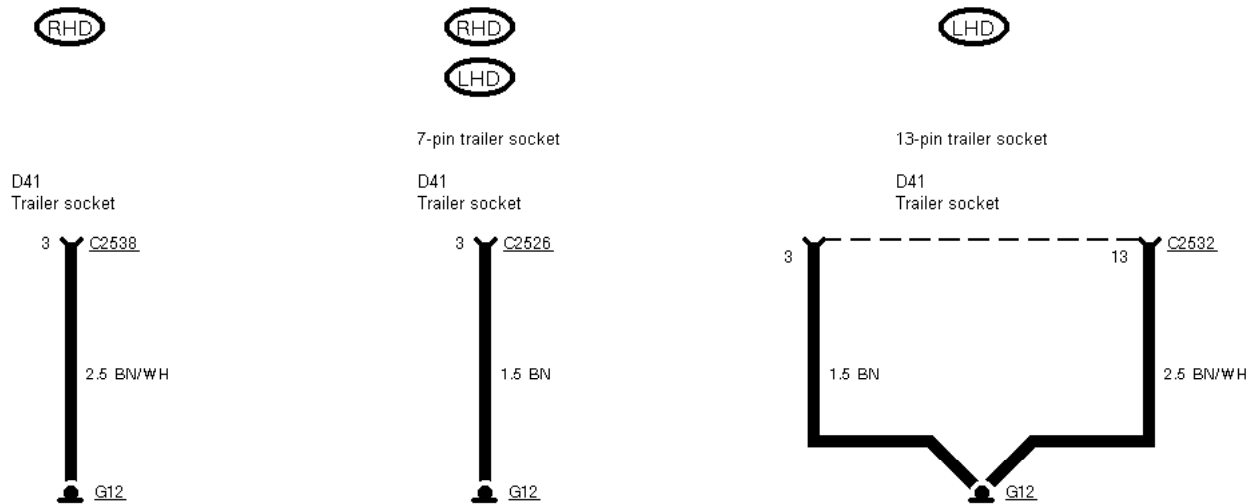

Ground G13 TCI Diesel from 02/95 to 09/96

Passive Anti-theft System (PATS)





01-04-096 , Ground Distribution , Ground G14

