

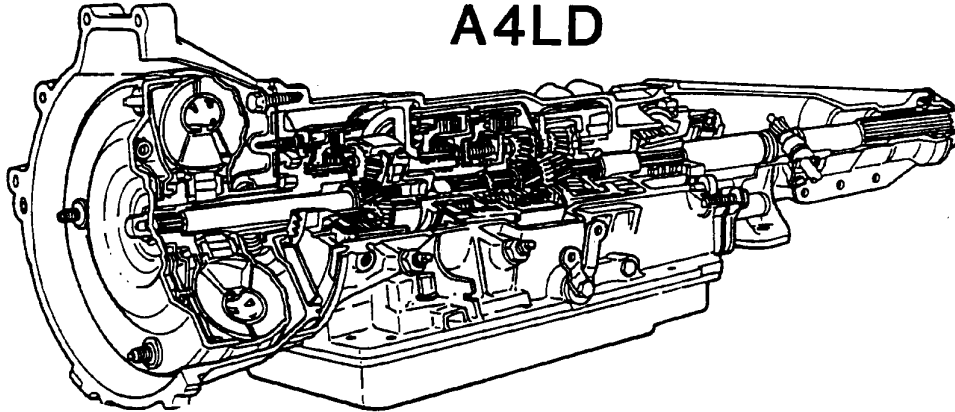

**ATSG**

# Technical Service Information

## A4LD



### Transmission Service Identification

All vehicles are equipped with a Safety Standard Certification Label affixed to the left (driver's) side door lock post. Refer to the stamped code in the space marked "Trans.:" for proper transmission identification. Plates and instructions for the specific transmission identification coding. The transmission is also identified by a tag on the transmission body.

MFD. BY FORD MOTOR CO. IN U.S.A.						
DATE:	GVWR:	FRONT GAWR:		REAR GAWR:		
		WITH TIRES RIMS		WITH TIRES RIMS		
AT	PSI COLD			AT	PSI COLD	
THIS VEHICLE CONFORMS TO ALL APPLICABLE FEDERAL MOTOR VEHICLE SAFETY STANDARDS IN EFFECT ON THE DATE OF MANUFACTURE SHOWN ABOVE.						
VEHICLE IDENTIFICATION NO.						
TYPE						DSG
EXTERIOR PAINT COLORS						
WB	TYPE	GVW	BODY	TRANS	AXLE	TAPE
						SPRINGS

TRANSMISSION CODE

### AUTOMATIC TRANSMISSION MODEL IDENTIFICATION

MODELS ARE IDENTIFIED BY A SERVICE IDENTIFICATION TAG AFFIXED TO THE ASSEMBLY. TAGS ARE LOCATED AND CONTAIN INFORMATION AS FOLLOWS:

A4LD	ATTACHED TO THE LOWER LEFT HAND EXTENSION ATTACHING BOLT.	<p style="text-align: center;">TRANSMISSION MODEL      LINE SHIFT CODE</p> <p style="text-align: center;">BUILD DAY CODE</p>
------	---	--

## AUTOMATIC TRANSMISSION SERVICE GROUP

**A4LD NAAO AUTOMATIC OVERDRIVE TRANSMISSION  
(BAND AND CLUTCH APPLICATION/GEAR RATIO)**

Gear	Overdrive Band A	Overdrive Clutch B	Overdrive One Way Clutch C	Intermediats Band D	Reverse and High Clutch E	Forward Clutch F	Low and Reverse Band G	One Way Clutch H	Gear Ratio
1 — Manual First Gear (Low)		Applied	Holding			Applied	Applied	Holding	2.47:1
2 — Manual Second Gear		Applied	Holding	Applied		Applied		Holding	1.47:1
D — Drive Auto. — 1st Gear		Applied	Holding			Applied		Holding	2.47:1
Ⓞ — OD Auto. — 1st Gear			Holding			Applied		Holding	2.47:1
D — Drive Auto. — 2nd Gear		Applied	Holding	Applied		Applied			1.47:1
Ⓞ — OD Auto. — 2nd Gear			Holding	Applied		Applied			1.47:1
D — Drive Auto. — 3rd Gear		Applied	Holding		Applied	Applied			1.0:1
Ⓞ — OD Auto. — 3rd Gear			Holding		Applied	Applied			1.0:1
Ⓞ — Overdrive Automatic Fourth Gear	Applied				Applied	Applied			0.75:1
Reverse		Applied	Holding		Applied		Applied		2.1:1

**Automatic Transmission Test Linkage Check Accelerator Linkage and Operation**  
 The linkage must be free and must return to idle when released.

**Manual Linkage**  
 This is a critical adjustment. Be sure the Ⓞ (Overdrive) detent in the transmission corresponds exactly with the stop in the console or column insert plate. Hydraulic leakage at the manual valve can cause delay in engagements and / or slipping while operating if the linkage is not properly adjusted.

\*Can be purchased as a separate item.

## Automatic Transmission Fluid Checking and Adding Procedure

Under normal circumstances, you do not need to check the fluid level of the transmission, since your vehicle does not use up transmission fluid. However, if the transmission is not working properly—for instance, the transmission may slip or shift slowly, or you may notice some sign of fluid leakage—the fluid level should be checked.

It is preferable to check the transmission fluid level at normal operating temperature, after approximately 20 miles (32 km) of driving. However, if necessary, you can check the fluid level without having to drive 20 miles to obtain a normal operating temperature if outside temperatures are above 10°C (50°F).

**NOTE:** If the vehicle has been operated for an extended period at high speeds or in city traffic during hot weather, or pulling a trailer, the vehicle should be turned off for about 30 minutes to allow the fluid to cool before checking.

### Checking The Automatic Transmission Fluid

With the vehicle on a level surface, start the engine and move the transmission shift selector through all of the gear ranges allowing sufficient time for each position to engage. Securely latch the transmission shift selector in the park position, fully set the parking brake and leave the engine running.

**NOTE:** Vehicles equipped with 4x4 applications must have the 4x4 shift selector in any position other than neutral.

**CAUTION: YOUR VEHICLE SHOULD NOT BE DRIVEN IF THE FLUID LEVEL IS BELOW THE BOTTOM HOLE ON THE DIPSTICK AND OUTSIDE TEMPERATURES ARE ABOVE 10°C (50°F).**

Wipe off the dipstick cap, pull the dipstick out and wipe the indicator end clean. Put the dipstick back into the filler tube and make sure it is fully seated. Pull the dipstick out and read the fluid level.

When checking fluid at normal operating temperature, the fluid level should be within the crosshatched area on the dipstick. When the vehicle has not been driven, and outside temperature is above 10°C (50°F). The fluid level should be between the holes on the dipstick.

### Adding Fluid

The fluid type is stamped on the dipstick. Before adding any fluid, be sure that the correct type will be used.

Add fluid in .25L (1/2 pint) increments through the filler tube to bring the level to the correct area on the dipstick. If an overfill occurs, excess fluid should be removed.

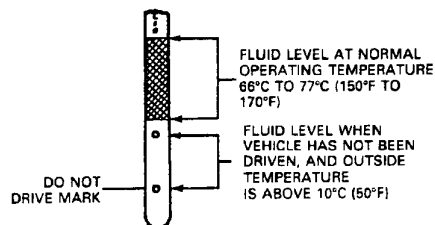

**Overfill** can cause the fluid to foam and spill out through the transmission vent resulting in a transmission malfunction.

**Underfill** can result in transmission loss of engagement or slipping. This condition is most evident in cold weather or when the vehicle is parked or being driven on a hill.

If the transmission fluid level is checked when the fluid is at room temperature the dipstick could indicate that fluid should be added if the dipstick is misread. If fluid is added at this time, an overfill condition could result when the fluid reaches operating temperatures of 66°C-77°C (150°F-170°F) (dipstick hot to touch).

### Transmission Fluid Condition Check

1. Make the normal fluid check according to the above procedure.
2. Observe color and odor of the fluid. It should be dark reddish, not brown or black. A burnt odor can sometimes indicate that there is an overheating condition or clutch disc or band failure.
3. Use an absorbent white paper (facial tissue, etc.) to wipe the dipstick. Examine the stain for evidence of solids (specks of any kind) and for antifreeze signs (gum or varnish on dipstick).

If specks are present in the oil or there is evidence of antifreeze, the transmission oil pan must be removed for further inspection. If antifreeze is found in the transmission fluid, the in-tank transmission cooler must be repaired or replaced. If fluid contamination or transmission failure is confirmed by further evidence of coolant or excessive solids in the oil pan, the transmission must be disassembled and completely cleaned and repaired. This includes cleaning the torque converter and transmission cooling system. It would be a waste of time to perform any further checks before cleaning and servicing the transmission.

During disassembly and assembly, all overhaul checks and adjustments of clearances and end play must be made.



## Transmission Fluid Leakage Checks

Check the speedometer cable connection at the transmission. Replace the rubber O-ring if necessary.

Leakage at the oil pan gasket often can be stopped by tightening the attaching bolts to the proper torque. If necessary, replace the gasket.

Check the fluid filler tube connection at the transmission case. Check filler tube O-ring seal for damage or omission. If leakage is found, install a new short oil inlet tube and O-ring seal, or clean the area and apply a sealer around the tube. The filler tube bracket should align properly and be attached to the transmission or engine locations.

Check the fluid lines and fittings between the transmission and the cooler in the radiator tank for looseness, wear, or damage. If leakage is found, tighten the fitting (as shown in chart below), or replace the damaged parts.

Transmission	Radiator		Transmission		Fluid Line Nut	
	(ft-lbs)	N-m	(ft-lbs)	N-m	(ft-lbs)	N-m
A4LD	(18-23)	24-31	(18-23)	24-31	(12-18)	16-24

Check the engine coolant in the radiator. If transmission fluid is present in the coolant, the cooler in the radiator is probably leaking.

The cooler can be further checked for leaks by disconnecting the lines from the cooler fittings and applying 345-517 kPa (50-75 psi) air pressure to the fittings. Remove the radiator cap to relieve the pressure buildup at the exterior of the oil cooler tank. If the cooler is leaking and / or will not hold pressure, the cooler must be replaced.

If leakage is found at the downshift control lever and the manual lever shaft, replace the seal.

Inspect the pipe plug on the left rear side of the transmission case. If the plug shows leakage, tighten the plug to specifications. If leakage continues, replace the plug.

**Fluid leakage from the converter housing may be caused by engine oil leakage past the rear main bearing, or from oil galley plugs, or power steering fluid leakage from steering system. Be sure to determine the exact cause of the leak before starting service procedures.**

Oil-soluble aniline or fluorescent dyes premixed at the rate of 1/2 teaspoon of dye powder to 0.23 liter (1/2 pint) of transmission fluid have proved helpful in locating the source of fluid leakage. Such dyes may be used to determine whether an engine oil or transmission fluid leak is present, or if the fluid in the oil cooler leaks into the engine coolant system. A black light must be used with the fluorescent dye solution.

## Fluid Leakage in Converter Area

In diagnosing and correcting fluid leaks in the front pump and converter area, use the following procedures to locate the exact cause of the leakage. Leakage at the front of the transmission, evidenced by fluid around the converter housing, may have several sources. By careful observation, it is possible in many instances, to pinpoint the source of the leak before removing the transmission from the vehicle. The paths which the fluid takes to reach the bottom of the converter housing are shown.

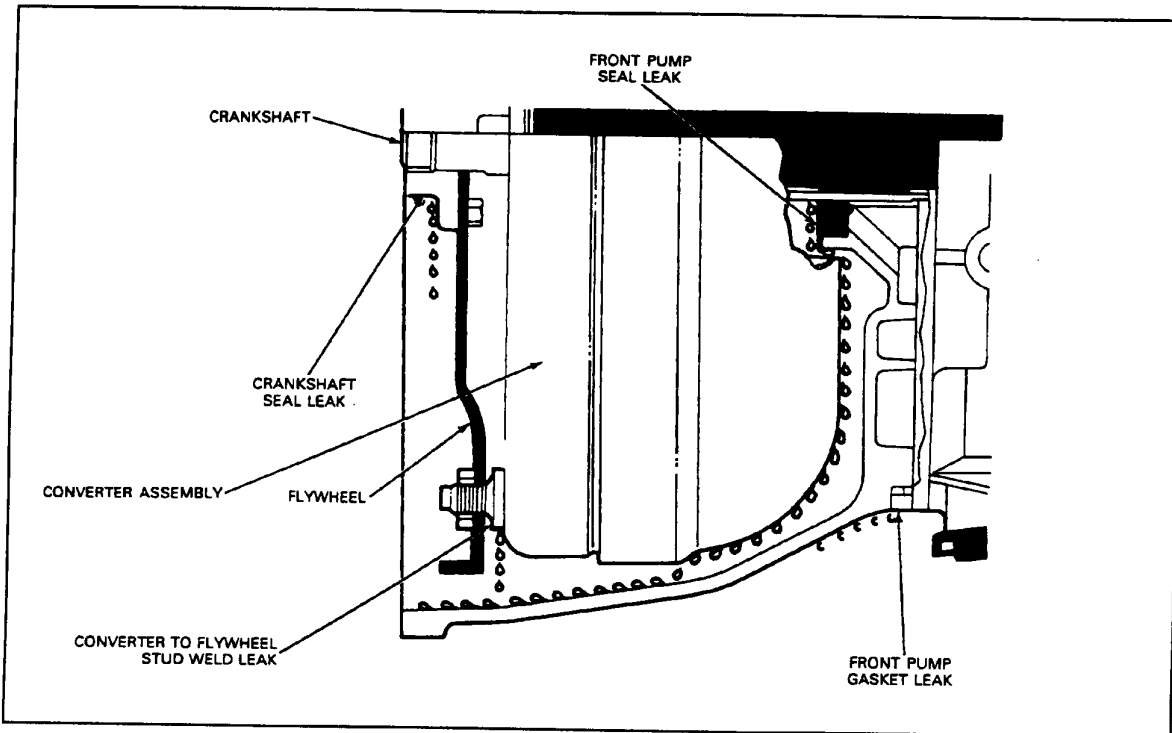

1. Fluid leaking by the front pump seal lip will tend to move along the impeller hub and onto the back of the impeller housing. Except in the case of a total seal failure, fluid leakage by the lip of the seal will be deposited on the inside of the converter housing only, near the outside diameter of the housing.
2. Fluid leakage by the outside diameter of the seal and front pump body will follow the same path which the leaks by the front pump seal follow.
3. Fluid that leaks by a front pump-to-case bolt will be deposited on the inside of the converter housing only. Fluid will not be deposited on the back of the converter.
4. Leakage by the front pump-to-case gasket may cause fluid to seep down between the front of the case and converter housing.
5. Fluid leakage from the converter-to-flywheel stud weld will appear at the outside diameter of the converter on the back face of the flywheel, and in the converter housing only near the flywheel.

Engine oil leaks are sometimes improperly diagnosed as transmission front pump seal leaks. The following areas of possible leakage should also be checked to determine if engine oil leakage is causing the problem:

- a. Leakage at the rocker arm cover (valley cover) may allow oil to flow over the converter housing or seep down between the converter housing and cylinder block, causing oil to be present in or at the bottom of the converter housing.
  - b. Oil galley plug leaks will allow oil to flow down the rear face of the block to the bottom of the converter housing.
  - c. Leakage by the crankshaft seal will work back to the flywheel, and then into the converter housing.
6. Fluid leakage from other areas, such as the power steering system forward of the transmission, could cause fluid to be present around the converter housing due to blow-back or road draft. The following procedures should be used to determine the cause of the leakage before any repairs are made.

- a. Remove the transmission dipstick and note the color of the fluid. Original factory-fill fluid is dyed red, to aid in determining if leakage is from the engine or transmission. Unless a considerable amount of makeup fluid has been added, or the fluid has been changed, the color should assist in pinpointing the leak. Since road draft may cause leaking power steering fluid to be present on the transmission, this leakage, if present, should be eliminated before checking the transmission for fluid leakage.
- b. Remove the converter housing cover. Clean off any fluid from the top and bottom of the converter housing, front of the transmission case, and rear face of the engine and engine oil pan. Clean the converter area by washing with a suitable nonflammable solvent, and blow dry with compressed air.
- c. Wash out the converter housing and the front of the flywheel. The converter housing may be washed out using cleaning solvent and a squirt-type oil can. Blow all washed areas dry with compressed air.
- d. Start and run the engine until the transmission reaches its normal operating temperature. Observe the back of the block and top of the converter housing for evidence of fluid leakage. Raise the vehicle on a hoist and run the engine at fast idle, then at engine idle, occasionally shifting to the drive and reverse ranges to increase pressure within the transmission. Observe the front of the flywheel, back of the block (in as far as possible), and inside the converter housing and front of the transmission case. Run the engine until fluid leakage is evident and the probable source of leakage can be determined.

### Converter Leakage Check

If welds on the torque converter indicate leakage, remove the converter and make the following check.

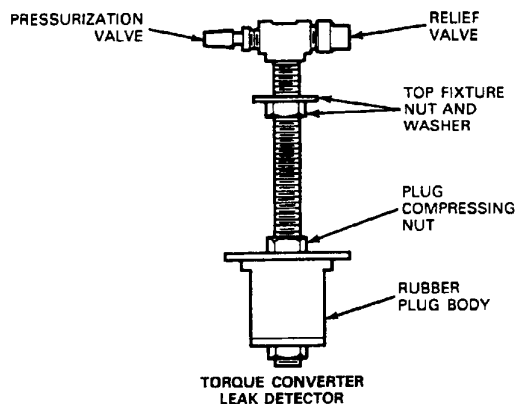

Assemble Rotunda 021-00047 or 021-00054 Torque Converter Leak Tester or equivalent to the converter as shown. Test the converter for leaks following the directions supplied with the detector kit.

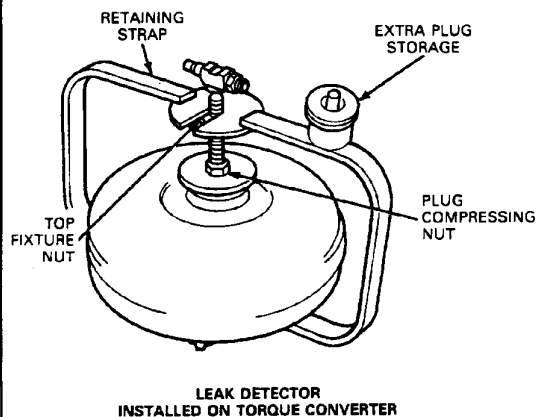

### Control Pressure Test

There are two methods of performing the control pressure test. One is to perform the test using the engine vacuum. The second method is to use a remote vacuum source such as the one provided by a distributor tester or a hand operated vacuum pump.

### Engine Vacuum Pressure

When the vacuum diaphragm unit is operating properly and the manual and downshift linkage is adjusted properly, all the transmission shifts (automatic and kickdown) should occur within the road speed limits listed in the Technical Service Bulletin—Special Specifications Issue.

If the shifts do not occur within limits, or the transmission slips during the shift point test, use the following procedure to determine whether the engine, transmission, linkage, vacuum diaphragm unit, or valve body is causing the condition.

## Engine Vacuum Procedure

1. Attach a tachometer to the engine and a Vacuum Gauge, Rotunda Number 059-00008, or equivalent to the transmission vacuum line at the manifold vacuum port.

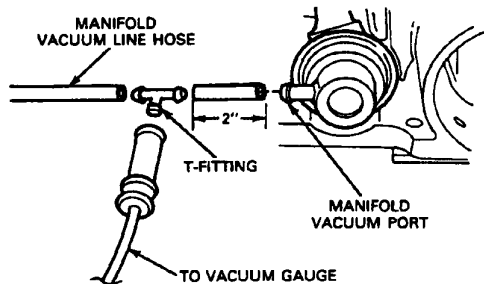

DIAPHRAGM CONNECTION

2. Attach a pressure gauge to the control pressure outlet at the transmission.

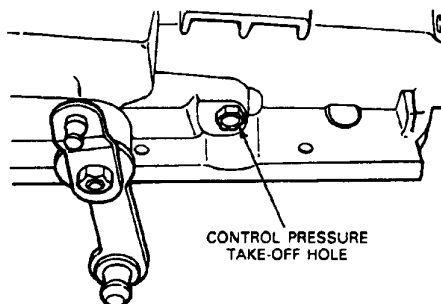

3. Firmly apply the parking brake and start the engine.
4. Check the throttle and downshift linkage for a binding condition. If linkage is satisfactory, check for vacuum leaks in the transmission diaphragm unit and its connecting tubes and hoses. Check all other vacuum-operated units (such as the power brake) for vacuum leaks.

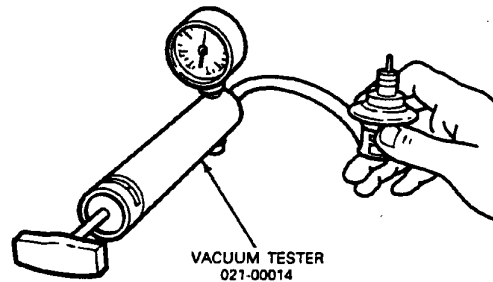

Refer to the two control pressure diagnostic guides to show what components are inoperative when the control pressure test is not within specifications. Do not proceed with the main diagnosis guide until you have made any repairs, as required, and the control pressure is within specifications as listed in the Performance Specifications Book or Special Specifications Issue of the Technical Service Bulletin.

## Vacuum Pump Method

Install an adjustable vacuum source. Disconnect and temporarily plug the vacuum line at the vacuum diaphragm unit. Apply both the parking and service brakes. Start the engine and vacuum pump. Set the vacuum at 15 inches, read and record the control pressure in all selector positions. Run the engine up to 1000 rpm, and reduce the vacuum to 10 inches. Read and record the control pressure in  $\odot$ , D-2 and 1. Keep the engine at 1000 rpm and reduce the vacuum to 1 inch. Read and record the control pressure in  $\odot$ , D-1, 2 and R.

Refer to the two control pressure diagnosis charts to show what components are inoperative when the control pressure test is not within specification. Do not proceed with the main diagnosis chart until serviced as required, and the control pressure is within specification as listed in the Performance Specifications Book or Special Specifications Issue of the Technical Service Bulletin.

## Engine Vacuum Procedure

1. Attach a tachometer to the engine and a Vacuum Gauge, Rotunda Number 059-00008, or equivalent to the transmission vacuum line at the manifold vacuum port.

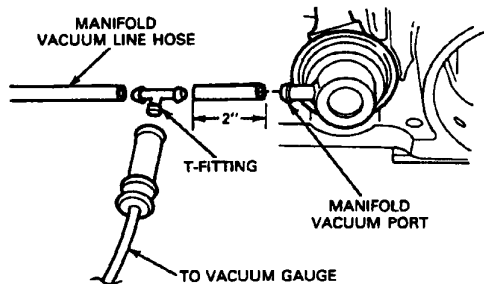

DIAPHRAGM CONNECTION

2. Attach a pressure gauge to the control pressure outlet at the transmission.

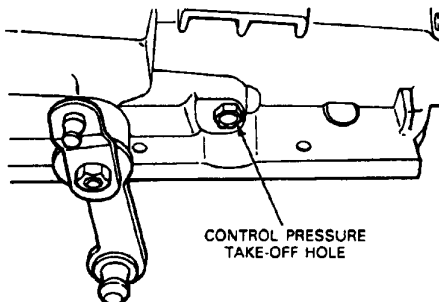

3. Firmly apply the parking brake and start the engine.
4. Check the throttle and downshift linkage for a binding condition. If linkage is satisfactory, check for vacuum leaks in the transmission diaphragm unit and its connecting tubes and hoses. Check all other vacuum-operated units (such as the power brake) for vacuum leaks.

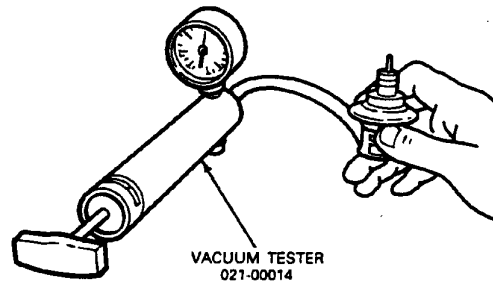

Refer to the two control pressure diagnostic guides to show what components are inoperative when the control pressure test is not within specifications. Do not proceed with the main diagnosis guide until you have made any repairs, as required, and the control pressure is within specifications as listed in the Performance Specifications Book or Special Specifications Issue of the Technical Service Bulletin.

## Vacuum Pump Method

Install an adjustable vacuum source. Disconnect and temporarily plug the vacuum line at the vacuum diaphragm unit. Apply both the parking and service brakes. Start the engine and vacuum pump. Set the vacuum at 15 inches, read and record the control pressure in all selector positions. Run the engine up to 1000 rpm, and reduce the vacuum to 10 inches. Read and record the control pressure in  $\odot$ , D-2 and 1. Keep the engine at 1000 rpm and reduce the vacuum to 1 inch. Read and record the control pressure in  $\odot$ , D-1, 2 and R.

Refer to the two control pressure diagnosis charts to show what components are inoperative when the control pressure test is not within specification. Do not proceed with the main diagnosis chart until serviced as required, and the control pressure is within specification as listed in the Performance Specifications Book or Special Specifications Issue of the Technical Service Bulletin.



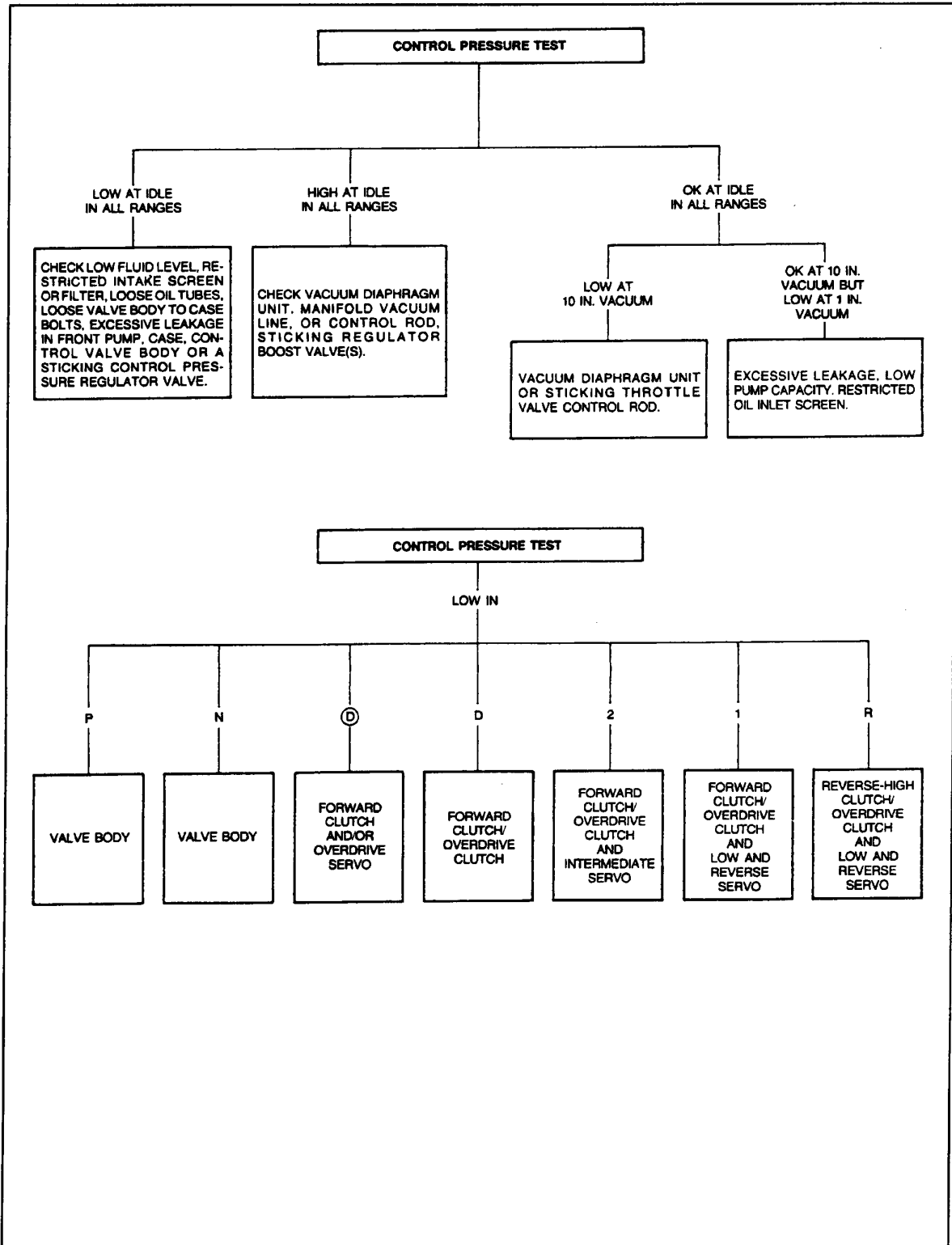



## Vacuum Supply Test

The vacuum supply to the vacuum diaphragm unit and the diaphragm itself must be checked. To check the supply, disconnect the vacuum line at the diaphragm unit and connect it to a vacuum gauge. With the engine idling, the gauge must have a steady acceptable vacuum reading for the altitude at which the test is being performed. If the vacuum reading is low, check for a vacuum leak or poor engine vacuum. If the vacuum reading is OK, rapidly accelerate the engine momentarily. The vacuum reading must drop rapidly at acceleration and return immediately upon release of the accelerator. If the vacuum reading does not change or changes slowly, the transmission vacuum line is plugged, restricted or connected to a reservoir supply. Correct as required.

## Vacuum Diaphragm Test—On Vehicle

To check the vacuum diaphragm unit, start the vacuum pump and set the regulator knob so that the vacuum gauge reads 18 inches with the end of the vacuum hose blocked off. Then connect the vacuum hose to the diaphragm unit. If the gauge still reads 18 inches, the vacuum diaphragm unit is not leaking. If the reading does not remain at 18 inches, but drops, the vacuum diaphragm unit is leaking. Replace the vacuum diaphragm unit. Also, if automatic transmission fluid is present in the vacuum side of the diaphragm or in the vacuum hose, the diaphragm is leaking and must be replaced.

## Vacuum Diaphragm Test—Off Vehicle

To check the vacuum unit for diaphragm leakage, remove the unit from the transmission. Use a Vacuum Tester, Rotunda Number 021-00014, or equivalent. Adjust the tester until the vacuum gauge reads 18 inches with the end of the vacuum hose blocked off.

Connect the vacuum hose to the manifold vacuum port as shown. If the gauge still reads 18 inches, the vacuum unit diaphragm is not leaking. A second leakage check can be made as the hose is removed from the transmission vacuum unit. Hold a finger over the end of the control rod. When the hose is removed the internal spring of the vacuum unit should push the control rod outward. If the vacuum diaphragm needs replacing, install a new unit that has been released for service. Vacuum diaphragm assembly identification is given at end of this section.

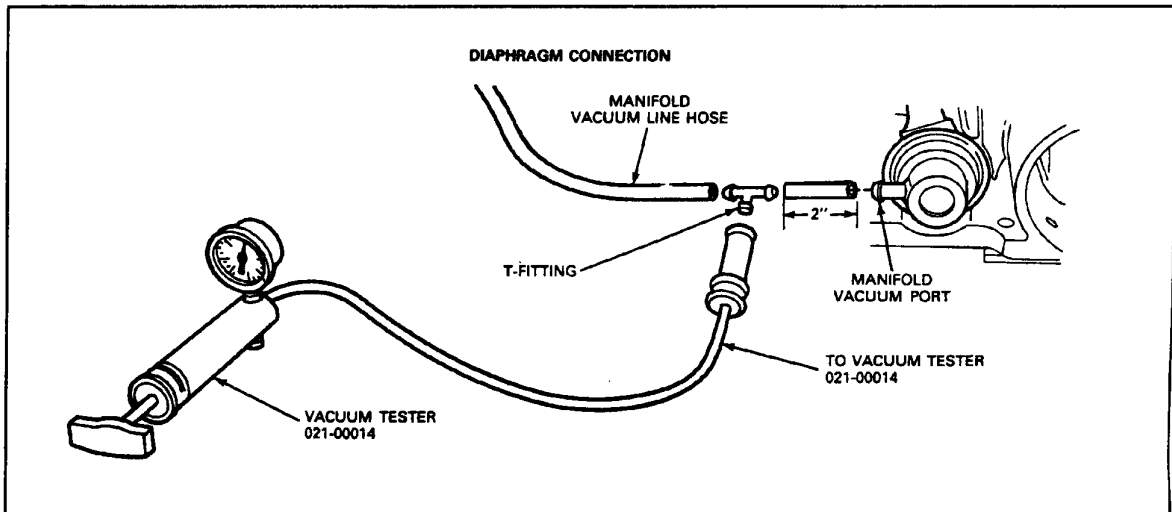

### Converter Clutch Test

**NOTE:** Engine coolant temperature must be above 53°C (128°F) and below 116°C (240°F). This temperature can be obtained after approximately 15 minutes of highway driving. Since most converter clutch shifts are difficult to feel (much less noticeable than a 1-2 or 2-3 upshift) a tachometer and/or vacuum gauge must be connected to the engine.

To check the converter clutch for engagement / disengagement, drive the vehicle at approximately 80 km/h (50 mph) and while maintaining this speed tap the brake pedal with the left foot. The engine rpm and vacuum should increase when the clutch disengages, with light brake pedal application, and decrease when the pedal is released and the clutch engages. If the converter clutch does not engage, see Diagnosis portion of this section.

### Stall Test

The stall test checks converter one-way clutch operation and installation, the holding ability of the forward clutch, reverse clutch, the low-reverse bands, the planetary one-way clutch and engine performance.

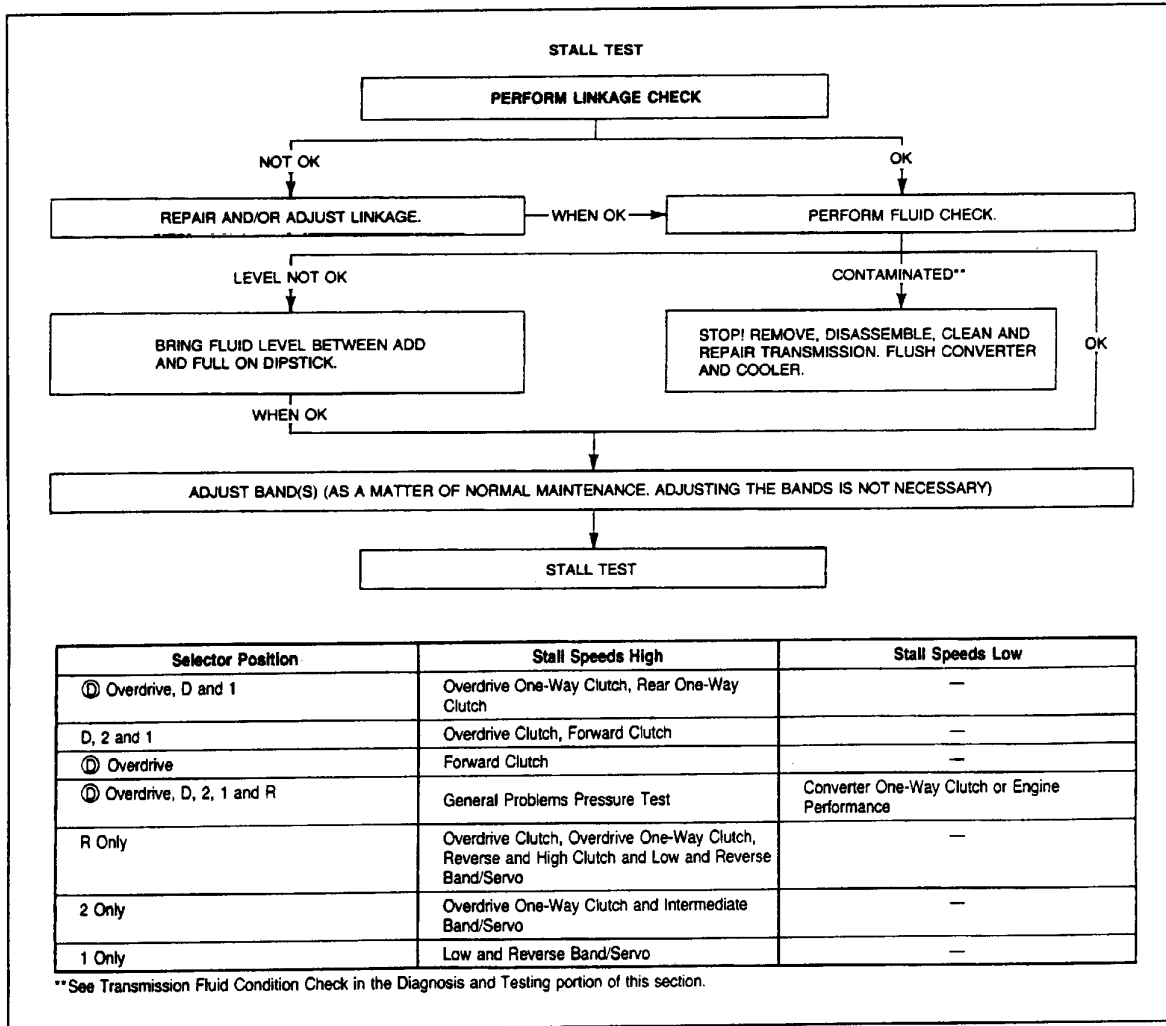

The test should be done only with the engine coolant and transmission fluid at proper levels and at operating temperature.

Apply the service and parking brakes firmly for each stall test.

1. Find the specified stall rpm for the vehicle by referring to the Performance Specification Book or Special Specifications Issue of the Technical Service Bulletin. Use a grease pencil to mark the rpm on the dial of a tachometer.
2. Connect the tachometer to the engine.
3. In each of the following ranges, D, 2, 1, R, press the accelerator to the floor and hold it just long enough to let the engine get to full rpm. While making this test, do not hold the throttle open for more than five seconds at a time.

4. Note the results in each range.
5. After each range, move the selector lever to N (Neutral) and run the engine at 1000 rpm for about 15 seconds to cool the converter before making the next test.

**CAUTION: If the engine speed recorded by the tachometer exceeds the maximum limits given in Specifications, release the accelerator immediately, because clutch or band slippage is indicated.**

**Governor Check**

The governor can be checked at the same time as the Control Pressure Test is performed and in the same manner.



Raise the vehicle with an axle or frame hoist so that the rear wheels are clear of the floor. Disconnect and plug the vacuum line to the vacuum diaphragm unit. Connect the line from the adjustable vacuum source to the vacuum diaphragm unit.

**CAUTION: Never exceed 96 km/h (60 mph) speedometer speed.**

Place the transmission in "D" or "D" range no load on the engine, and apply 10 inches of vacuum to the vacuum diaphragm unit. Increase the speed slowly and watch the speedometer. Check the km/h (mph) at which the control pressure cutback occurs. It should occur between 13-19 km/h (5-15 mph). Decrease the vacuum at the vacuum diaphragm to 0-2 inches. Control pressure cutback should occur between 18-28 km/h (7-20 mph).

NOTE: After each test, move the selector to N (Neutral) and run the engine at 1000 rpm to cool the transmission.

The governor is good if the cutback occurs within these specifications. If the cutback does not occur within specifications, check shift speed to verify that it is the governor and not a stuck cutback valve, then service or replace the governor.

### Transmission Fluid Cooler Flow Check

The linkage, fluid level and control pressure must be within specifications before performing this flow check.

Remove the transmission dipstick from the filler tube. Place a funnel in the transmission filler tube. Raise the vehicle; remove the cooler return line from its fitting in the case. Attach a hose to the cooler return line and fasten the free end of the hose in the funnel installed in the filler tube.

Start the engine and set idle speed at 1000 rpm with the transmission in N (Neutral).

Observe the fluid flow at the funnel. When the flow is "solid" (air bleeding has been completed), the flow should be liberal. If there is not a liberal flow at 1000 rpm in N (Neutral), low pump capacity, main circuit system leakage, stuck converter charge relief valve or cooler system restriction is indicated.

To separate transmission trouble from cooler system trouble, observe the flow at the transmission case converter-out fitting.

### Shift Point Checks

#### Road Test

This check will determine if the electronics, governor and shift control valves are functioning properly.

Check the light throttle upshifts with selector in overdrive range  $\text{Ⓞ}$ . (Approximately 10 inches Hg vacuum.) The transmission should start in first gear, shift to second gear, shift to third gear, shift to fourth gear (overdrive) and then lock the converter clutch. The converter lockup is often difficult to feel, therefore a vacuum gauge and tachometer should be used to determine lockup shift points. Refer to the Ford Performance Specifications Book or the Special Specifications Issue of the Technical Service Bulletin for actual shift point vehicle speed.

When the selector lever is in D position, the transmission will make all automatic upshifts except the 3-4.

When the selector is at 2 (Second), the transmission can operate only in second gear.

With the transmission in third gear and road speed over 72 km/h (45 mph) the transmission should shift to second gear when the selector lever is moved from D (Drive) or 2 (Second) to 1 (First). **This check will determine if the governor pressure and shift control valves are functioning properly.**

If the vehicle is traveling at approximately 72 km/h (45 mph) and the selector lever is moved from  $\text{Ⓞ}$  (Overdrive) to 1 or D to 1 (closed throttle), the transmission will immediately downshift to second gear. As road speed drops below 48 km/h (30 mph) the transmission will downshift to first gear.

For a coastdown from approximately 72 km/h (45 mph) with the transmission in  $\text{Ⓞ}$  position and at closed throttle, the downshift sequence is as follows: converter clutch unlocks electronically when the accelerator pedal is released, as vehicle speed drops, 4-3, 3-2 and finally 2-1 downshifts happen.

#### In Shop

A shift test can be performed in the shop to check shift valve operation, governor circuits, shift delay pressures, throttle boost and downshift valve action.

Raise the vehicle with an axle or frame hoist so that the rear wheels are clear of the floor. Disconnect and plug the vacuum line from the engine to the diaphragm. Connect the line from the adjustable vacuum source to the vacuum diaphragm unit.

**CAUTION: Never exceed 96 km/h (60 mph) speedometer speed.**

1. To check the shift valves and governor circuits, apply 18 inches of vacuum to the transmission vacuum diaphragm unit. Place the transmission in  $\text{Ⓞ}$  (Overdrive) and make a minimum throttle 1-2, 2-3, 3-4, and lockup shift. If the shift points are within specification, the 1-2, 2-3 converter clutch and 3-4 shift valves and governor are OK.

If the shift points are not within specification, perform a governor check to isolate the problem.

NOTE: After each test, move the selector lever to Neutral, run the engine at 1000 rpm to cool the transmission.

2. To check the shift delay pressures and throttle boost, decrease the vacuum at the vacuum diaphragm to 0-2 inches. Make a 1-2 shift test. If the shift point raises to specification, the throttle boost and shift delay systems are functioning.  
 NOTE: After each test, move the selector lever to Neutral, run the engine at 1000 rpm to cool the transmission.
3. To check downshift valve action, leave the vacuum to the vacuum diaphragm at 0-2 inches. Position the downshift linkage in the wide open throttle position (through the detent) and repeat the 1-2 shift test. The speed at the shift point should be higher.

Shift speed specifications can be found in the Performance Specifications Book, or the Special Specifications Issue of the Technical Service Bulletin.

### Air Pressure Checks

A NO DRIVE condition can exist, even with correct transmission fluid pressure, because of inoperative clutches or bands. On automatic transmissions, an erratic shift can be caused by a stuck governor valve. The inoperative units can be located through a series of checks by substituting air pressure for fluid pressure to determine the locations of the malfunction.

When the selector lever is at 2 (Second) a NO DRIVE condition may be caused by an inoperative forward clutch. A NO DRIVE condition at D (Drive) may be caused by an inoperative forward clutch or one-way clutch. When there is no drive in 1 (Low) the difficulty could be caused by improper functioning of the forward clutch or simultaneous malfunction of the low-reverse band and the one-way clutch. Failure to drive in R (Reverse) could be caused by a malfunction of the reverse-high clutch or low-reverse band.

To make the air pressure checks, loosen the oil pan bolts and lower one edge to drain the transmission fluid. Remove the oil pan and the control valve body assembly. The inoperative clutches or bands can be located by introducing air pressure into the various transmission case passages.

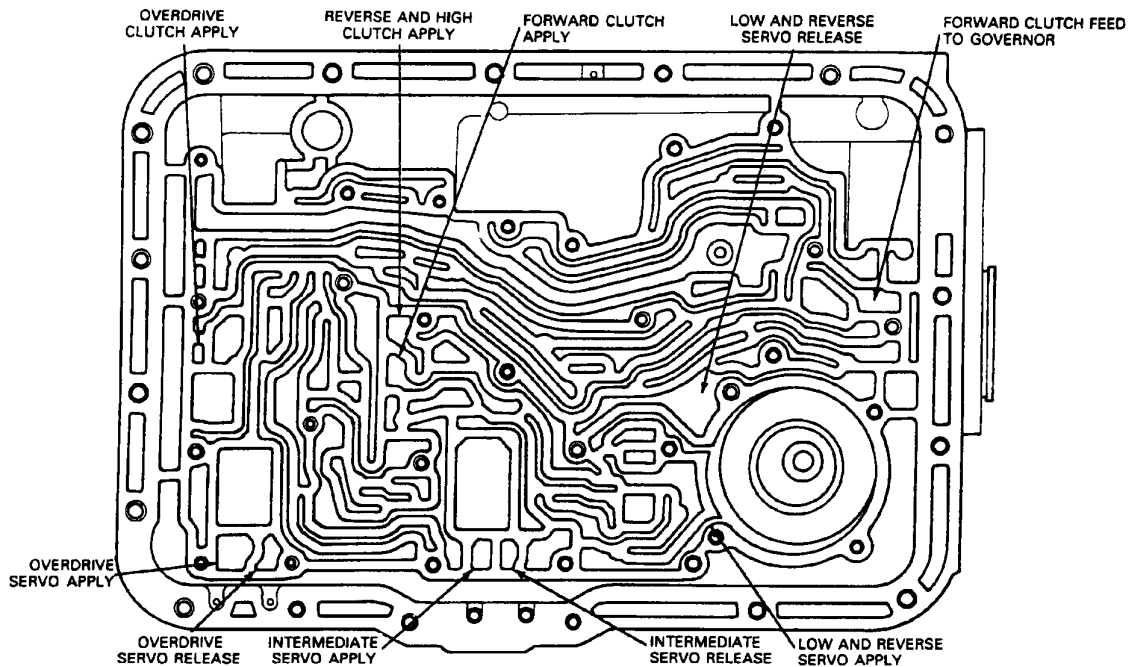



## Forward Clutch

Apply air pressure to the transmission case forward clutch passages. A dull thud can be heard when the clutch piston is applied. If no noise is heard, place the finger tips on the input shell and again apply air pressure to the forward or front clutch passage. Movement of the piston can be felt as the clutch is applied.

## Governor

Apply air pressure to the forward clutch feed to governor passage and listen for a sharp clicking or whistling noise. The noise indicates governor valve movement.

## Overdrive Servo

Hold the air nozzle in the overdrive servo apply passage. Operation of the servo is indicated by a tightening of the overdrive band around the overdrive drum. Continue to apply air pressure to the servo apply passage and introduce air pressure into the overdrive servo release passage. The overdrive servo should stroke off releasing the overdrive band.

## Overdrive Clutch

(Applied in D, 2, 1 and R ranges.) Apply air pressure to the overdrive clutch feed passage. A dull thud indicates that the overdrive clutch piston has moved to the applied position.

## Reverse-High Clutch

Apply air pressure to the reverse-high clutch. A dull thud indicates that the reverse-high clutch piston has moved to the applied position. If no noise is heard, place the finger tips on the clutch drum and again apply air pressure to detect movement of the piston.

## Intermediate Servo

Hold the air nozzle in the intermediate servo apply passages. Operation of the servo is indicated by a tightening of the intermediate band around the drum. Continue to apply air pressure to the servo apply passage, and introduce air pressure into the intermediate servo release passage. The intermediate servo should release the band against the apply pressure.

## Low-Reverse Servo

Apply air pressure to the low-reverse servo. The low-reverse band should tighten around the drum if the servo is operating properly.

## Air Pressure Check Diagnosis

If the servos do not operate, disassemble, clean, and inspect them to locate the source of the trouble.

If air pressure applied to either of the clutch passages fails to operate a clutch or operates both clutches at once, remove, and with air pressure, check the fluid passages in the case and front pump to detect obstructions.

## Converter Clutch Operation

In the A4LD transmission, converter clutch upshifts and downshifts are scheduled hydraulically, but can be overridden electronically. The converter clutch is inhibited from engaging during the following driving modes:

- Engine coolant below 60°C (128°F) or above 115°C (240°F)
- Application of brakes
- Closed throttle
- Heavy or WOT acceleration
- Quick tip-ins
- Quick tip-outs
- When actual engine speed is below a certain value at lower vacuums (this insures all 4-3 torque demands will be made on an unlocked converter)

During the above driving modes no current flows through the solenoid. To illustrate the operation of the system refer to the following illustrations. When the converter clutch shuttle valve is resting on the plug, line pressure is directed through the shuttle valve and to the torque converter in a flow path that pushes the lockup piston off. Refer to Converter Clutch Unlocked schematic. When line pressure on the spring end of the converter clutch shuttle valve is exhausted, line pressure on the plug end of the valve forces the valve to move and compress the spring. Line pressure is now directed through the shuttle valve to the converter in a flow path that pushes the piston on. Refer to Converter Clutch Locked schematic.

In CONVERTER CLUTCH LOCKED position, lockup is permitted electronically because the vehicle is not operating in any of the above driving modes. (The processor energizes the solenoid by grounding the signal line.) In CONVERTER CLUTCH UNLOCKED position, governor pressure acting on the converter clutch shift valve has not yet moved the valve to the upshifted position. Line pressure is therefore acting on the spring end of the converter clutch shuttle valve. The torque converter is therefore unlocked. As vehicle speed increases, governor pressure increases and the converter clutch shift valve moves to the upshifted position. Oil on the spring end of the converter clutch shuttle valve now drains to exhaust at the converter clutch shift valve. The shuttle valve takes the position as shown in the CONVERTER CLUTCH LOCKED position and the torque converter locks up. If the brakes are applied or the vehicle is operated in any of the other inhibit modes, current will not flow through the solenoid. With no current to the solenoid, line pressure can flow through the solenoid valving and enter the lockup inhibition passage. See CONVERTER CLUTCH UNLOCKED (ELECTRONICALLY INHIBITED). Line pressure in the inhibition passage forces the shuttle ball to take the position as shown. The shuttle valve moves up against the plug and the converter unlocks.

Since this is a hybrid system in many cases it will be necessary to check both the electronic and hydraulic portions of the system.

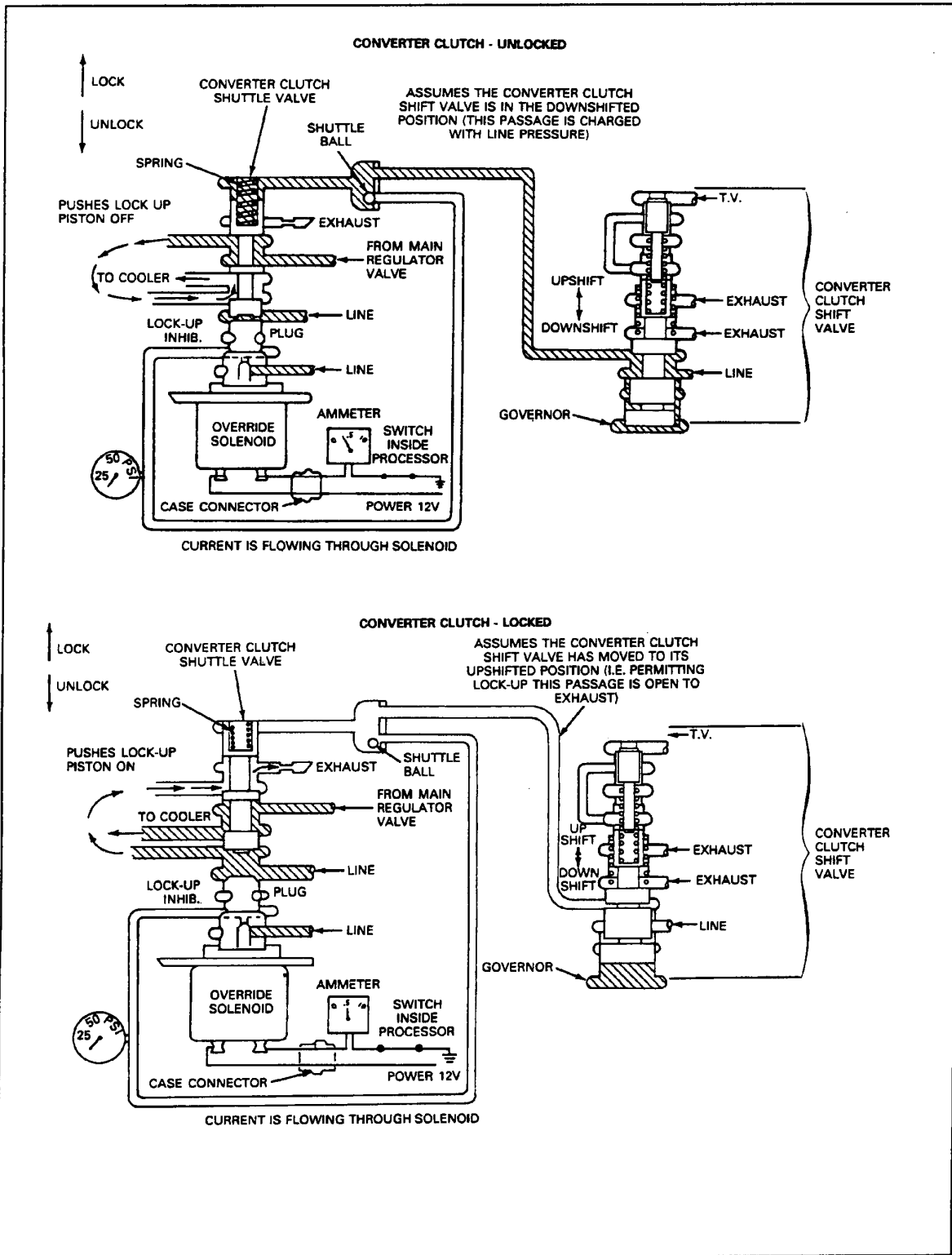



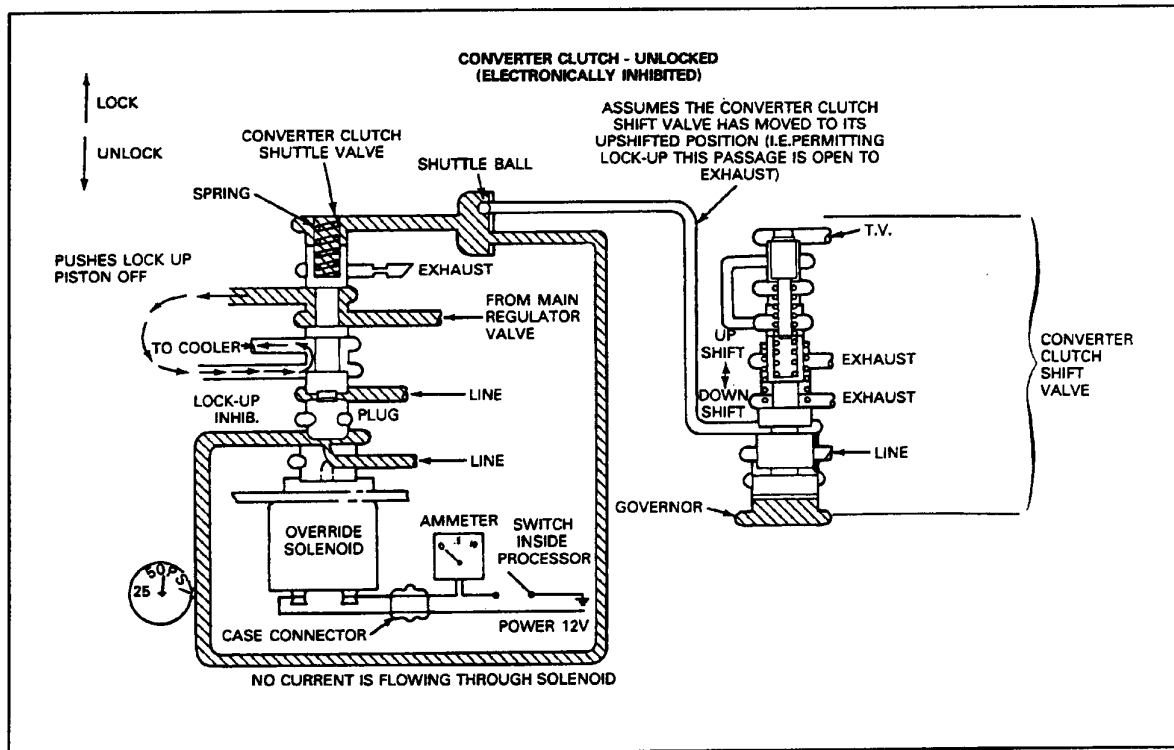



# Technical Service Information

CONDITION	POSSIBLE CAUSE	RESOLUTION
Converter clutch does not engage.	<ol style="list-style-type: none"> <li>1. Converter clutch solenoid is not being energized electrically. Wires to solenoid shorted or an open circuit. Transmission case connector not seated. Open or short circuit inside of solenoid. Malfunctioning engine coolant temperature sensor. Malfunctioning throttle position sensor. Malfunctioning manifold absolute pressure sensor. Vacuum line disconnected from the MAP sensor.</li> <li>2. Circuit continuity: 3-4 solenoid wire pin 52 should read approximately 20 ohm resistance.</li> <li>3. Brake switch malfunction.</li> <li>4. Malfunctioning EEC-IV processor.</li> <li>5. Converter clutch solenoid is being energized electronically but foreign material on solenoid valve is preventing valve closure.</li> <li>6. Converter clutch shuttle valve stuck in unlock position (against plug) or too high a load spring.</li> <li>7. Converter clutch shift valve stuck in downshift position.</li> <li>8. Torque converter internal malfunction preventing lock-up piston application.</li> </ol>	<ol style="list-style-type: none"> <li>1. Perform EEC-IV diagnostic check — key on — engine off.①</li> <li>2. Check circuit continuity with breakout box, Tool No. T83L-50, and volt ohm meter. Check power pin No. 57 (red lead) and 3-4 pin 52 (black lead).</li> <li>3. Perform EEC-IV Diagnostic Check — Engine running.①</li> <li>4. Run diagnostic check on processor.①</li> <li>5. Remove transmission oil pan. Remove valve body. Remove solenoid and check operation of solenoid. Clean if necessary.</li> <li>6. Remove valve body. Check operation of converter clutch shuttle valve. Remove any contamination. Spring load should be approximately 2.0 lbs. at 0.512 inch.</li> <li>7. Remove valve body. Check operation of converter clutch shift valve. Remove any contamination. Be sure valve moves freely.</li> <li>8. Remove transmission. Replace converter.</li> </ol>
Converter clutch always engaged even at zero road speed. (Symptom: Vehicle will move only when the engine is accelerated to a high RPM and transmission selector level is placed into <b>D</b> .)	<ol style="list-style-type: none"> <li>1. Converter clutch shift valve stuck in lock position.</li> <li>2. Converter clutch shuttle valve stuck in locked position.</li> <li>3. Lock-up piston in torque converter will not disengage.</li> </ol>	<ol style="list-style-type: none"> <li>1. Remove transmission valve body. Check to see that converter clutch shift valve moves freely.①</li> <li>2. Remove valve body. Check converter clutch shuttle valve for ease of movement.</li> <li>3. Remove transmission. Replace converter.</li> </ol>
Converter clutch will not disengage on coastdown.	<ol style="list-style-type: none"> <li>1. Malfunctioning throttle position sensor (should unlock at closed throttle).</li> <li>2. Converter clutch solenoid sticking.</li> </ol>	<ol style="list-style-type: none"> <li>1. Perform EEC-IV Diagnostic Check — key on — engine off.</li> <li>2. Remove valve body. Check operation of solenoid. Replace if required.</li> </ol>

① Refer to the Emission Diagnosis Engine/Electronics Manual — EEC Quick Test procedures\*.  
 \*This manual can be purchased as a separate item.



## DIAGNOSIS — AUTOMATIC TRANSMISSION

CONDITION	POSSIBLE CAUSE	ACTION
Slow initial engagement.	<ol style="list-style-type: none"> <li>1. Improper fluid level.</li> <li>2. Damaged or improperly adjusted manual linkage.</li> <li>3. Contaminated fluid.</li> <li>4. Improper clutch and band application, or low main control pressure.</li> </ol>	<ol style="list-style-type: none"> <li>1. Perform fluid level check.</li> <li>2. Service or adjust manual linkage.</li> <li>3. Perform fluid condition check.</li> <li>4. Perform control pressure test.</li> </ol>
Rough initial engagement in either forward or reverse.	<ol style="list-style-type: none"> <li>1. Improper fluid level.</li> <li>2. High engine idle.</li> <li>3. Automatic choke on (warm temp.).</li> <li>4. Looseness in the driveshaft. U-joints or engine mounts.</li> <li>5. Improper clutch or band application, or oil control pressure.</li> <li>6. Sticking or dirty valve body.</li> <li>7. Converter clutch not disengaging.</li> </ol>	<ol style="list-style-type: none"> <li>1. Perform fluid level check.</li> <li>2. Adjust idle to specification.</li> <li>3. Service as required.</li> <li>4. Service as required.</li> <li>5. Perform control pressure test.</li> <li>6. Clean, service or replace valve body.</li> <li>7. Check converter clutch engagement/disengagement.</li> </ol>
Harsh engagements — (warm engine).	<ol style="list-style-type: none"> <li>1. Improper fluid level.</li> <li>2. Engine curb idle speed too high.</li> <li>3. Valve body bolts — loose/too tight.</li> <li>4. Valve body dirty/sticking valves.</li> </ol>	<ol style="list-style-type: none"> <li>1. Perform fluid level check.</li> <li>2. Check engine curb idle speed.</li> <li>3. Tighten to specification.</li> <li>4. Determine source of contamination. Service as required.</li> </ol>
No/delayed forward engagement (reverse OK).	<ol style="list-style-type: none"> <li>1. Improper fluid level.</li> <li>2. Manual linkage — misadjusted/damaged.</li> <li>3. Low main control pressure (leakage). Forward clutch center support seal rings leaking.</li> <li>4. Forward clutch assembly burnt/damaged/leaking. Check ball in cylinder/leaking piston seal rings.</li> <li>5. Valve body bolts — loose/too tight.</li> <li>6. Valve body dirty/sticking valves.</li> <li>7. Transmission filter plugged.</li> <li>8. Pump damaged, leaking.</li> </ol>	<ol style="list-style-type: none"> <li>1. Perform fluid level check.</li> <li>2. Check and adjust or service as required.</li> <li>3. Control pressure test, note results.</li> <li>4. Perform air pressure test.</li> <li>5. Tighten to specification.</li> <li>6. Determine source of contamination. Service as required.</li> <li>7. Replace filter.</li> <li>8. Visually inspect pump gear. Replace pump if necessary.</li> </ol>



# Technical Service Information

## DIAGNOSIS — AUTOMATIC TRANSMISSION (Cont'd.)

CONDITION	POSSIBLE CAUSE	ACTION
No/delayed reverse engagement (forward OK).	<ol style="list-style-type: none"> <li>1. Improper fluid level.</li> <li>2. Manual linkage misadjusted/damaged.</li> <li>3. Low main control pressure in reverse.</li> <li>4. Reverse clutch assembly burnt/worn/leaking check ball in piston/leaking piston seal rings.</li> <li>5. Valve body bolts loose/too tight.</li> <li>6. Valve body dirty/sticking valves.</li> <li>7. Transmission filter plugged.</li> <li>8. Pump damaged.</li> <li>9. Low/reverse servo piston seal cut/leaking.</li> </ol>	<ol style="list-style-type: none"> <li>1. Perform fluid level check.</li> <li>2. Check and adjust or service as required.</li> <li>3. Control pressure test.</li> <li>4. Perform air pressure test.</li> <li>5. Tighten to specification.</li> <li>6. Determine source of contamination. Service as required.</li> <li>7. Replace filter.</li> <li>8. Visually inspect pump gears. Replace pump if necessary.</li> <li>9. Perform air pressure test. Check and replace piston seal. Check and replace low/reverse band.</li> </ol>
No engagement or drive in forward (any position) or reverse.	<ol style="list-style-type: none"> <li>1. Improper fluid level.</li> <li>2. Low main control pressure.</li> <li>3. Mechanical damage.</li> </ol>	<ol style="list-style-type: none"> <li>1. Perform fluid level check.</li> <li>2. Control pressure test.</li> <li>3. Check splines on turbine, input shaft and O/D carrier, O/D one-way clutch, center shaft, forward clutch, forward carrier and output shaft. Replace if necessary.</li> </ol>
No engagement/drive in D or D (2 and 1 OK)	<ol style="list-style-type: none"> <li>1. Manual linkage misadjusted.</li> <li>2. Rear one-way clutch damaged.</li> <li>3. Dirty/contaminated transmission fluid.</li> <li>4. Overdrive one-way clutch damage.</li> </ol>	<ol style="list-style-type: none"> <li>1. Adjust manual linkage.</li> <li>2. Replace rear one-way clutch.</li> <li>3. Clean transmission and valve body.</li> <li>4. Repair or replace.</li> </ol>
Vehicle creeping in neutral.	<ol style="list-style-type: none"> <li>1. Forward clutch failing to disengage.</li> </ol>	<ol style="list-style-type: none"> <li>1. Clean transmission.</li> </ol>



# Technical Service Information

## DIAGNOSIS — AUTOMATIC TRANSMISSION

CONDITION	POSSIBLE SOURCE	ACTION
No/delayed reverse engagement and/or no engine braking in manual low (1).	<ol style="list-style-type: none"> <li>1. Improper fluid level.</li> <li>2. Linkage out of adjustment.</li> <li>3. Low reverse servo piston seal leaking.</li> <li>4. Low reverse band burnt or worn.</li> <li>5. Overdrive clutch, overdrive one-way clutch damaged.</li> <li>6. Polished, glazed low/reverse band or drum.</li> <li>7. Rear one-way clutch damaged.</li> </ol>	<ol style="list-style-type: none"> <li>1. Perform fluid level check.</li> <li>2. Service or adjust linkage.</li> <li>3. Check and replace piston seal.</li> <li>4. Perform air pressure test.</li> <li>5. Replace as required.</li> <li>6. Service or replace as required.</li> <li>7. Replace.</li> </ol>
No engine braking in manual second gear.	<ol style="list-style-type: none"> <li>1. Intermediate band out of adjustment.</li> <li>2. Improper band or clutch application, or oil pressure control system.</li> <li>3. Intermediate servo leaking.</li> <li>4. Overdrive clutch, O/D one-way clutch damaged.</li> <li>5. Glazed band.</li> </ol>	<ol style="list-style-type: none"> <li>1. Adjust intermediate band.</li> <li>2. Perform control pressure test.</li> <li>3. Perform air pressure test of intermediate servo for leakage. Service as required.</li> <li>4. Replace as required.</li> <li>5. Service or replace as required.</li> </ol>
Forward engagement slips/shudders/chatters.	<ol style="list-style-type: none"> <li>1. Improper fluid level.</li> <li>2. Manual linkage misadjusted/damaged.</li> <li>3. Low main control pressure.</li> <li>4. Valve body bolts — loose/too tight.</li> <li>5. Valve body dirty/sticking valves.</li> <li>6. Forward clutch piston ball check not seating/leaking.</li> <li>7. Forward clutch piston seals cut/worn.</li> <li>8. O/D one-way clutch damaged.</li> <li>9. Rear one-way clutch damaged.</li> </ol>	<ol style="list-style-type: none"> <li>1. Perform fluid level check.</li> <li>2. Check and adjust or service as required.</li> <li>3. Control pressure test.</li> <li>4. Tighten to specification.</li> <li>5. Determine source of contamination. Service as required.</li> <li>6. Replace forward clutch piston. Service transmission as required.</li> <li>7. Replace seal and service clutch as required.</li> <li>8. Replace as required.</li> <li>9. Determine cause of condition. Service as required.</li> </ol>



# Technical Service Information

## DIAGNOSIS — AUTOMATIC TRANSMISSION

CONDITION	POSSIBLE SOURCE	ACTION
Reverse shudder/chatters/slips.	<ol style="list-style-type: none"> <li>1. Improper fluid level.</li> <li>2. Low main control pressure in reverse.</li> <li>3. Low-reverse servo leaking.</li> <li>4. O/D and/or rear one-way clutch damaged.</li> <li>5. O/D and/or rear reverse-high clutch drum bushing damaged.</li> <li>6. O/D and/or rear reverse-high clutch center support seal rings/ ring grooves worn/damaged.</li> <li>7. O/D and/or rear reverse-high clutch piston seals cut/worn.</li> <li>8. Low-reverse servo piston damaged/worn.</li> <li>9. Low-reverse band out of adjustment or damaged.</li> <li>10. Looseness in the driveshaft, U-joints or engine mounts.</li> <li>11. Low/reverse servo piston/seals or bores damaged.</li> <li>12. Contamination blockage in cooler lines, in-tank radiator or auxiliary cooler.</li> </ol>	<ol style="list-style-type: none"> <li>1. Perform fluid level check.</li> <li>2. Control pressure test.</li> <li>3. Air pressure test. Visually inspect seal rings and piston bore.</li> <li>4. Determine cause of condition. Service as required.</li> <li>5. Determine cause of condition. Service as required.</li> <li>6. Determine cause of condition. Service as required.</li> <li>7. Determine cause of condition. Service as required.</li> <li>8. Service as required.</li> <li>9. Adjust and inspect low-reverse band.</li> <li>10. Service as required.</li> <li>11. Perform air pressure check.</li> <li>12. Perform transmission fluid cooler flow check.</li> </ol>



## DIAGNOSIS — AUTOMATIC TRANSMISSION

CONDITION	POSSIBLE CAUSE	RESOLUTION
<ul style="list-style-type: none"> <li>No drive, slips or chatters in first gear in (D) D. All other gears normal.</li> </ul>	<ol style="list-style-type: none"> <li>Damaged or worn rear one-way clutch.</li> </ol>	<ol style="list-style-type: none"> <li>Service or replace rear one-way clutch.</li> </ol>
<ul style="list-style-type: none"> <li>No drive, slips or chatters in second gear.</li> </ul>	<ol style="list-style-type: none"> <li>Intermediate band out of adjustment.</li> <li>Improper band or clutch application, or control pressure.</li> <li>Damaged or worn intermediate servo piston and/or internal leaks.</li> <li>Dirty or sticking valve body.</li> <li>Polished, glazed intermediate band or drum.</li> </ol>	<ol style="list-style-type: none"> <li>Adjust intermediate band.</li> <li>Perform control pressure test.</li> <li>Perform air pressure test.</li> <li>Clean, service or replace valve body.</li> <li>Replace or service as required.</li> </ol>
<ul style="list-style-type: none"> <li>Starts up in 2nd or 3rd.</li> </ul>	<ol style="list-style-type: none"> <li>Improper band and/or clutch application, or oil pressure control system.</li> <li>Damaged or worn governor. Sticking governor.</li> <li>Valve body loose.</li> <li>Dirty or sticking valve body.</li> <li>Cross leaks between valve body and case mating surface.</li> </ol>	<ol style="list-style-type: none"> <li>Perform control pressure test.</li> <li>Perform governor check. Replace or service governor, clean screen.</li> <li>Tighten to specification.</li> <li>Clean, service or replace valve body.</li> <li>Service or replace valve body and or case as required.</li> </ol>
<ul style="list-style-type: none"> <li>Shift points incorrect.</li> </ul>	<ol style="list-style-type: none"> <li>Improper fluid level.</li> <li>Vacuum line damaged, clogged or leaks.</li> <li>Improper operation of EGR system.</li> <li>Improper speedometer gear installed.</li> <li>Improper clutch or band application, or oil pressure control system.</li> <li>Damaged or worn governor.</li> <li>Vacuum diaphragm bent, sticking or leaks.</li> <li>Dirty or sticking valve body.</li> </ol>	<ol style="list-style-type: none"> <li>Perform fluid level check.</li> <li>Perform vacuum supply test.</li> <li>Service or replace as required.</li> <li>Replace gear.</li> <li>Perform shift test and control pressure test.</li> <li>Service or replace governor — clean screen.</li> <li>Service or replace as required.</li> <li>Clean, service or replace valve body.</li> </ol>
<ul style="list-style-type: none"> <li>All upshifts harsh/delayed or no upshifts.</li> </ul>	<ol style="list-style-type: none"> <li>Improper fluid level.</li> <li>Manual linkage — misadjusted damaged.</li> <li>Governor sticking.</li> <li>Main control pressure too high.</li> <li>Valve body bolts — loose/too tight.</li> <li>Valve body dirty/sticking valves.</li> <li>Vacuum leak to diaphragm unit.</li> <li>Vacuum diaphragm bent, sticking, leaks.</li> </ol>	<ol style="list-style-type: none"> <li>Perform fluid level check.</li> <li>Check and adjust or service as required.</li> <li>Perform governor test. Service as required.</li> <li>Control pressure test. Service as required.</li> <li>Tighten to specification.</li> <li>Determine source of contamination. Service as required.</li> <li>Perform vacuum supply and diaphragm test. Check vacuum lines to diaphragm unit. Service as required.</li> <li>Check diaphragm unit. Service as required.</li> </ol>



# Technical Service Information

## DIAGNOSIS — AUTOMATIC TRANSMISSION

CONDITION	POSSIBLE CAUSE	RESOLUTION
Mushy/early all upshifts pile up/upshifts	<ol style="list-style-type: none"> <li>1. Low main control pressure.</li> <li>2. Valve body bolts loose/too tight.</li> <li>3. Valve body or throttle control valve sticking.</li> <li>4. Governor valve sticking.</li> <li>5. Kickdown linkage misadjusted, sticking or damaged.</li> </ol>	<ol style="list-style-type: none"> <li>1. Control pressure test. Note results.</li> <li>2. Tighten to specification.</li> <li>3. Determine source of contamination. Service as required.</li> <li>4. Perform governor test. Repair as required.</li> <li>5. Adjust linkage, service as required.</li> </ol>
No 1-2 upshift.	<ol style="list-style-type: none"> <li>1. Improper fluid level.</li> <li>2. Kickdown system damaged.</li> <li>3. Manual linkage — misadjusted damaged.</li> <li>4. Governor valve sticking.</li> <li>5. Intermediate band out of adjustment.</li> <li>6. Vacuum leak to diaphragm unit.</li> <li>7. Vacuum diaphragm bent, sticking, leaks.</li> <li>8. Valve body bolts — loose/too tight.</li> <li>9. Valve body dirty/sticking valves.</li> <li>10. Intermediate band and/or servo assembly burnt.</li> </ol>	<ol style="list-style-type: none"> <li>1. Perform fluid level check.</li> <li>2. Replace damaged parts.</li> <li>3. Check and adjust or service as required.</li> <li>4. Perform governor test. Service as required.</li> <li>5. Adjust intermediate band.</li> <li>6. Check vacuum lines to diaphragm. Service as required.</li> <li>7. Check diaphragm unit. Service as necessary.</li> <li>8. Tighten to specification.</li> <li>9. Determine source of contamination. Service as required.</li> <li>10. Perform air pressure test.</li> </ol>
Rough/harsh/delayed 1-2 upshift.	<ol style="list-style-type: none"> <li>1. Improper fluid level.</li> <li>2. Poor engine performance.</li> <li>3. Kickdown linkage misadjusted.</li> <li>4. Intermediate band out of adjustment.</li> <li>5. Main control pressure too high.</li> <li>6. Governor valve sticking.</li> <li>7. Damaged intermediate servo.</li> <li>8. Engine vacuum leak.</li> <li>9. Valve body bolts — loose/too tight.</li> <li>10. Valve body dirty/sticking valves.</li> <li>11. Vacuum leak to diaphragm unit.</li> <li>12. Vacuum diaphragm bent, sticking, leaks.</li> </ol>	<ol style="list-style-type: none"> <li>1. Perform fluid level check.</li> <li>2. Tune engine.</li> <li>3. Adjust linkage.</li> <li>4. Adjust intermediate band.</li> <li>5. Control pressure test. Note results.</li> <li>6. Perform governor test. Service as required.</li> <li>7. Air pressure check intermediate servo.</li> <li>8. Check engine vacuum lines. Check vacuum diaphragm unit. Perform vacuum supply and diaphragm test. Service as necessary.</li> <li>9. Tighten to specifications.</li> <li>10. Determine source of contamination. Service as required.</li> <li>11. Check vacuum lines to diaphragm unit. Service as required.</li> <li>12. Check diaphragm unit. Service as necessary.</li> </ol>





## DIAGNOSIS — AUTOMATIC TRANSMISSION

CONDITION	POSSIBLE CAUSE	RESOLUTION
Mush/early/soft/slipping 1-2 upshift.	<ol style="list-style-type: none"> <li>1. Improper fluid level.</li> <li>2. Main regulator or throttle valve stuck.</li> <li>3. Incorrect engine performance.</li> <li>4. Intermediate band out of adjustment.</li> <li>5. Low main control pressure.</li> <li>6. Valve body bolts loose/too tight.</li> <li>7. Valve body dirty/sticking valves.</li> <li>8. Governor valve sticking.</li> <li>9. Damaged intermediate servo or band.</li> <li>10. Polished, glazed intermediate band or drum.</li> </ol>	<ol style="list-style-type: none"> <li>1. Perform fluid level check.</li> <li>2. Service as required.</li> <li>3. Tune engine as required.</li> <li>4. Adjust intermediate band.</li> <li>5. Control pressure test. Note results.</li> <li>6. Tighten to specification.</li> <li>7. Determine source of contamination. Service as required.</li> <li>8. Perform governor test. Service as required.</li> <li>9. Perform air pressure test. Service as required.</li> <li>10. Service or replace as required.</li> </ol>
No 2-3 upshift.	<ol style="list-style-type: none"> <li>1. Low fluid level.</li> <li>2. Kickdown system damaged.</li> <li>3. Low main control pressure to reverse-high clutch.</li> <li>4. Valve body bolts — loose/too tight.</li> <li>5. Valve body dirty/sticking valves.</li> <li>6. Reverse/high clutch assembly burnt/worn.</li> </ol>	<ol style="list-style-type: none"> <li>1. Perform fluid level check.</li> <li>2. Replace damaged parts.</li> <li>3. Control pressure test. Note results.</li> <li>4. Tighten to specification.</li> <li>5. Determine source of contamination, then service as required.</li> <li>6. Determine cause of condition. Service as required.</li> </ol>
Harsh/delayed 2-3 upshift.	<ol style="list-style-type: none"> <li>1. Incorrect engine performance.</li> <li>2. Engine vacuum leak.</li> <li>3. Kickdown system damaged.</li> <li>4. Damaged or worn intermediate servo release and reverse-high clutch piston check ball.</li> <li>5. Valve body bolts — loose/too tight.</li> <li>6. Valve body dirty/sticking valves.</li> <li>7. Vacuum diaphragm bent, sticking, leaks.</li> <li>8. Throttle valve stuck.</li> </ol>	<ol style="list-style-type: none"> <li>1. Check engine tune-up.</li> <li>2. Check engine vacuum lines. Check vacuum diaphragm unit. Perform vacuum supply and diaphragm test. Service as necessary.</li> <li>3. Replace damaged parts.</li> <li>4. Air pressure test the intermediate servo apply and release the reverse-high clutch piston check ball. Service as required.</li> <li>5. Tighten to specification.</li> <li>6. Determine source of condition. Service as required.</li> <li>7. Check diaphragm. Replace as necessary.</li> <li>8. Service as required.</li> </ol>



# Technical Service Information

## DIAGNOSIS — AUTOMATIC TRANSMISSION

CONDITION	POSSIBLE CAUSE	RESOLUTION
Soft/early/mushy 2-3 upshift.	<ol style="list-style-type: none"> <li>1. Kickdown system damaged.</li> <li>2. Valve body bolts loose/too tight.</li> <li>3. Valve body dirty/sticking valves.</li> <li>4. Vacuum diaphragm or TV control rod bent, sticking, leaks.</li> <li>5. Throttle valve stuck.</li> </ol>	<ol style="list-style-type: none"> <li>1. Replace damaged parts.</li> <li>2. Tighten to specification.</li> <li>3. Determine source of contamination. Service as required.</li> <li>4. Check diaphragm and rod. Replace as necessary.</li> <li>5. Service as required.</li> </ol>
Erratic shifts.	<ol style="list-style-type: none"> <li>1. Poor engine performance.</li> <li>2. Vacuum line damaged.</li> <li>3. Valve body bolts — loose/too tight.</li> <li>4. Valve body dirty/sticking valves.</li> <li>5. Governor valve stuck.</li> <li>6. Output shaft collector body seal rings damaged.</li> </ol>	<ol style="list-style-type: none"> <li>1. Check engine tune-up.</li> <li>2. Service as required.</li> <li>3. Tighten to specification.</li> <li>4. Air pressure test, note results. Determine source of contamination. Service as required.</li> <li>5. Perform governor test. Service as required.</li> <li>6. Service as required.</li> </ol>
Shifts 1-3 in $\text{\textcircled{D}}$ or D.	<ol style="list-style-type: none"> <li>1. Intermediate band out of adjustment.</li> <li>2. Damaged intermediate servo and/or internal leaks.</li> <li>3. Improper band or clutch application, or oil pressure control system.</li> <li>4. Polished glazed band or drum.</li> <li>5. Dirty/sticky valve body, or governor.</li> <li>6. Governor valve stuck.</li> <li>7. Kickdown system out of adjustment.</li> </ol>	<ol style="list-style-type: none"> <li>1. Adjust band.</li> <li>2. Perform air pressure test. Service front servo and/or internal leaks.</li> <li>3. Perform control pressure test.</li> <li>4. Service or replace band or drum.</li> <li>5. Clean, service or replace valve body or governor.</li> <li>6. Perform governor test. Service as required.</li> <li>7. Adjust kickdown system.</li> </ol>
Engine over-speeds on 2-3 shift.	<ol style="list-style-type: none"> <li>1. Kickdown system damaged.</li> <li>2. Improper band or clutch application, or oil pressure control system.</li> <li>3. Damaged or worn reverse high clutch and/or intermediate servo piston.</li> <li>4. Intermediate servo piston seals cut, leaking.</li> <li>5. Dirty or sticking valve body.</li> <li>6. Throttle valve stuck.</li> <li>7. Damaged vacuum diaphragm.</li> </ol>	<ol style="list-style-type: none"> <li>1. Replace damaged parts.</li> <li>2. Perform control pressure test.</li> <li>3. Perform air pressure test. Service as required.</li> <li>4. Replace seals. Check for leaks.</li> <li>5. Clean, service or replace valve body.</li> <li>6. Service as required.</li> <li>7. Replace vacuum diaphragm.</li> </ol>



# Technical Service Information

## DIAGNOSIS – AUTOMATIC TRANSMISSION

CONDITION	POSSIBLE CAUSE	RESOLUTION
Rough/shudder 3-2 shift at closed throttle in D.	<ol style="list-style-type: none"> <li>1. Incorrect engine idle or performance.</li> <li>2. Improper kickdown linkage adjustment.</li> <li>3. Improper clutch or band application or oil pressure control system.</li> <li>4. Improper governor operation.</li> <li>5. Dirty or sticking valve body.</li> </ol>	<ol style="list-style-type: none"> <li>1. Tune, and adjust engine idle.</li> <li>2. Service or adjust kickdown linkage.</li> <li>3. Perform control pressure test.</li> <li>4. Perform governor test. Service as required.</li> <li>5. Clean, service or replace valve body.</li> </ol>
No 3-4 upshift.	<ol style="list-style-type: none"> <li>1. 3-4 shift solenoid is not being energized electrically. Wires shorted or an open circuit.  Circuit continuity: 3-4 solenoid wire pin 52 should read approx. 20 ohm resistance.</li> <li>2. Trans. case connector and harness connector not seated.</li> <li>3. Malfunction of: <ul style="list-style-type: none"> <li>● EEC IV processor</li> <li>● Vacuum line disconnected from map sensor.</li> <li>● Map sensor.</li> <li>● Throttle position sensor.</li> <li>● Vehicle speed sensor.</li> </ul> </li> <li>4. Check O.D. band adjustment.</li> <li>5. Overdrive servo damaged or leaking.</li> <li>6. Polished or glazed overdrive band or drum.</li> <li>7. Contaminated or sticking 3-4 shift valve.</li> <li>8. Contaminated and sticking 3-4 solenoid.</li> </ol>	<ol style="list-style-type: none"> <li>1. Perform EEC IV diagnostic check – key on – engine off.  Check circuit continuity with breakout box tool no. T83L-50, and volt ohm meter.  Check power pin no. 57 (red lead) and 3-4 pin 52 (black lead).</li> <li>2. If not seated, check for contamination, clean and reconnect.  Perform EEC IV diagnostic check – key on – engine off.</li> <li>3. Perform EEC IV diagnostic check – key on – engine off.</li> <li>4. Reset band to 2.0 turns for 2.3, 2.9 and 3.0L or 3.5 turns for 4.0L applications.</li> <li>5. Check cover seal and piston assembly – replace if required.</li> <li>6. Service or replace.</li> <li>7. Clean or replace valve body. Check 3-4 shift valve for freedom of movement.</li> <li>8. Clean or replace 3-4 solenoid and filter sleeve assembly.</li> </ol>
Slipping 4 <sup>th</sup> Gear	<ol style="list-style-type: none"> <li>1. Check O.D. band adjustment.</li> <li>2. Overdrive servo damaged or leaking.</li> <li>3. Polished or glazed overdrive band or drum.</li> </ol>	<ol style="list-style-type: none"> <li>1. Reset band to 2.0 turns for 2.3, 2.9 and 3.0L, or 3.5 turns for 4.0L applications.</li> <li>2. Check cover seal and piston assembly – replace if required.</li> <li>3. Service or replace.</li> </ol>
Engine stall speed exceeded in <b>D</b> , <b>D</b> or <b>R</b> .	<ol style="list-style-type: none"> <li>1. Vacuum system.</li> <li>2. Low main control pressure.</li> </ol>	<ol style="list-style-type: none"> <li>1. Check and service vacuum system.</li> <li>2. Control pressure test. Check and clean valve body. Replace valve body gasket. Check or service pump.</li> </ol>



# Technical Service Information

## DIAGNOSIS — AUTOMATIC TRANSMISSION — (Cont'd.)

CONDITION	POSSIBLE CAUSE	RESOLUTION
Engine stall speed exceeded in R. OK in (D), D, 2 and 1.	<ol style="list-style-type: none"> <li>1. Low/reverse servo/band damaged.</li> <li>2. Reverse and high clutch damaged.</li> </ol>	<ol style="list-style-type: none"> <li>1. Check engine braking in 1. If not OK, check service or replace if required the low/reverse servo and band.</li> <li>2. If low/reverse servo OK, check and repair reverse and high clutch.</li> </ol>
Engine stall speed exceeded in (D) or D. OK in R.	<ol style="list-style-type: none"> <li>1. O/D one-way clutch or rear one-way clutch damaged.</li> </ol>	<ol style="list-style-type: none"> <li>1. Check engine stall speeds in 2 and 1. If OK, repair O/D or rear one-way clutches. Clean transmission.</li> </ol>
1-2 upshift is above 64 km/h (40 mph) at moderate acceleration.	<ol style="list-style-type: none"> <li>1. Vacuum system.</li> <li>2. Main control pressure.</li> <li>3. Governor damaged or worn.</li> <li>4. Dirty or sticking valve body.</li> </ol>	<ol style="list-style-type: none"> <li>1. Check and service hoses and vacuum diaphragm if required.</li> <li>2. Control pressure test.</li> <li>3. Perform governor check. Replace or service governor.</li> <li>4. Clean, service or replace valve body.</li> </ol>



# Technical Service Information

## DIAGNOSIS — AUTOMATIC TRANSMISSION

CONDITION	POSSIBLE CAUSE	RESOLUTION
Kickdown shift speeds too early.	<ol style="list-style-type: none"> <li>1. Kickdown system damaged.</li> <li>2. Main control pressure.</li> <li>3. Governor damaged or worn.</li> </ol>	<ol style="list-style-type: none"> <li>1. Replace damaged parts.</li> <li>2. Perform control pressure test.</li> <li>3. Perform governor check. Replace or service governor.</li> </ol>
No kickdown into 2nd gear between 64-100 km/h (40-60 mph) in <b>D</b> or D.	<ol style="list-style-type: none"> <li>1. Kickdown system damaged.</li> <li>2. Main control pressure.</li> <li>3. Dirty or sticking valve body.</li> <li>4. Kickdown cable over adjusted.</li> </ol>	<ol style="list-style-type: none"> <li>1. Replace damaged parts.</li> <li>2. Perform control pressure test.</li> <li>3. Check kickdown valve. Clean or replace valve body.</li> <li>4. Adjust kickdown cable.</li> </ol>
No shift into 2nd gear with accelerator 3/4 depressed at 40 km/h (25 mph) in <b>D</b> or D.	<ol style="list-style-type: none"> <li>1. Main control pressure.</li> <li>2. Governor damaged or worn.</li> <li>3. Dirty or sticking valve body.</li> </ol>	<ol style="list-style-type: none"> <li>1. Control pressure test.</li> <li>2. Check governor.</li> <li>3. Clean or replace valve body.</li> </ol>
When moving selector from <b>D</b> or D to manual 1, at 86 km/h (55 mph) with accelerator released, no braking felt from downshift to 2nd gear.	<ol style="list-style-type: none"> <li>1. Main control pressure.</li> <li>2. Intermediate band out of adjustment.</li> <li>3. Overdrive clutch damaged.</li> </ol>	<ol style="list-style-type: none"> <li>1. Perform control pressure test.</li> <li>2. Adjust band. Check intermediate servo.</li> <li>3. Repair or replace overdrive clutch.</li> </ol>
When moving selector from <b>D</b> or D to manual 1, at 86 km/h (55 mph) with accelerator released, shift into 1st gear occurs over 72 km/h (45 mph).	<ol style="list-style-type: none"> <li>1. Main control pressure.</li> <li>2. Dirty or sticking valve body.</li> <li>3. Governor damaged or worn.</li> <li>4. Kickdown linkage misadjusted or stuck.</li> </ol>	<ol style="list-style-type: none"> <li>1. Perform main control pressure test.</li> <li>2. Clean or replace valve body.</li> <li>3. Perform governor check. Replace or service governor.</li> <li>4. Adjust or repair kickdown linkage.</li> </ol>
When moving selector from <b>D</b> or D to manual 1, at 86 km/h (55 mph) with accelerator released. First gear shift occurs under 24 km/h (15 mph)	<ol style="list-style-type: none"> <li>1. Main control pressure.</li> <li>2. Dirty or sticking valve body.</li> <li>3. Low/reverse servo damaged.</li> <li>4. Governor damaged or worn.</li> <li>5. Overdrive clutch damaged.</li> </ol>	<ol style="list-style-type: none"> <li>1. Perform control pressure test.</li> <li>2. Clean or replace valve body.</li> <li>3. Check and service as required.</li> <li>4. Perform governor check. Replace or service governor.</li> <li>5. Repair or replace as required.</li> </ol>



# Technical Service Information

## DIAGNOSIS — AUTOMATIC TRANSMISSION

CONDITION	POSSIBLE CAUSE	RESOLUTION
No forced downshifts.	<ol style="list-style-type: none"> <li>1. Kickdown cable damaged.</li> <li>2. Kickdown cable over adjusted.</li> <li>3. Damaged internal kickdown linkage.</li> <li>4. Improper clutch or band application, or oil pressure control system.</li> <li>5. Dirty or sticking governor.</li> <li>6. Dirty or sticking valve body.</li> </ol>	<ol style="list-style-type: none"> <li>1. Replace damaged parts.</li> <li>2. Adjust kickdown cable.</li> <li>3. Service internal kickdown linkage.</li> <li>4. Perform control pressure test.</li> <li>5. Service or replace governor, clean screen.</li> <li>6. Clean, service, or replace valve body.</li> </ol>
Engine over-speeds on 3-2 downshift.	<ol style="list-style-type: none"> <li>1. Linkage out of adjustment.</li> <li>2. Intermediate band out of adjustment.</li> <li>3. Improper band or clutch application, and one way clutch, or oil pressure control system.</li> <li>4. Damaged or worn intermediate servo.</li> <li>5. Polished, glazed band or drum.</li> <li>6. Dirty or sticking valve body.</li> </ol>	<ol style="list-style-type: none"> <li>1. Service or adjust linkage.</li> <li>2. Adjust intermediate band.</li> <li>3. Perform control pressure test service clutch.</li> <li>4. Air pressure test check the intermediate servo. Service servo and or seals.</li> <li>5. Service or replace as required.</li> <li>6. Clean, service or replace valve body.</li> </ol>
Shift efforts high.	<ol style="list-style-type: none"> <li>1. Manual shaft linkage damaged/ misadjusted.</li> <li>2. Inner manual lever nut loose.</li> <li>3. Manual lever retainer pin damaged.</li> </ol>	<ol style="list-style-type: none"> <li>1. Check and adjust or service as required.</li> <li>2. Tighten nut to specification.</li> <li>3. Adjust linkage and install pin.</li> </ol>
Transmission overheats.	<ol style="list-style-type: none"> <li>1. Improper fluid level.</li> <li>2. Incorrect engine idle, or performance.</li> <li>3. Improper clutch or band application, or oil pressure control system.</li> <li>4. Restriction in cooler or lines.</li> <li>5. Seized converter one-way clutch.</li> <li>6. Dirty or sticking valve body.</li> </ol>	<ol style="list-style-type: none"> <li>1. Perform fluid level check.</li> <li>2. Tune, or adjust engine idle.</li> <li>3. Perform control pressure test.</li> <li>4. Service restriction.</li> <li>5. Replace one-way clutch.</li> <li>6. Clean, service or replace valve body.</li> </ol>
Transmission leaks.	<ol style="list-style-type: none"> <li>1. Case breather vent.</li> <li>2. Leakage at gasket, seals, etc.</li> </ol>	<ol style="list-style-type: none"> <li>1. Check the vent for free breathing. Repair as required.</li> <li>2. Remove all traces of lube on exposed surfaces of transmission. Check the vent for free breathing. Operate transmission at normal temperatures and perform fluid leakage check. Service as required.</li> </ol>
Poor vehicle acceleration.	<ol style="list-style-type: none"> <li>1. Poor engine performance.</li> <li>2. Torque converter one-way clutch slipping.</li> </ol>	<ol style="list-style-type: none"> <li>1. Check engine tune up.</li> <li>2. Replace torque converter.</li> </ol>
Transmission noisy — valve resonance.  NOTE: Gauges may aggravate any hydraulic resonance. Remove gauge and check for resonance level.	<ol style="list-style-type: none"> <li>1. Improper fluid level.</li> <li>2. Linkage out of adjustment.</li> <li>3. Improper band or clutch application, or oil pressure control system.</li> <li>4. Cooler lines grounding.</li> <li>5. Dirty or sticking valve body.</li> <li>6. Internal leakage or pump cavitation.</li> </ol>	<ol style="list-style-type: none"> <li>1. Perform fluid level check.</li> <li>2. Service or adjust linkage.</li> <li>3. Perform control pressure test.</li> <li>4. Free up cooler lines.</li> <li>5. Clean, service or replace valve body.</li> <li>6. Service as required.</li> </ol>
Engine stalls when shifting into forward or reverse.	<ol style="list-style-type: none"> <li>1. Low engine idle.</li> <li>2. Broken converter clutch shuttle valve spring.</li> </ol>	<ol style="list-style-type: none"> <li>1. Verify that engine idle speeds are set to specifications.</li> <li>2. Replace converter clutch shuttle valve spring.</li> </ol>



# Technical Service Information

## TRANSMISSION NOISY — OTHER THAN VALVE RESONANCE

TEST STEP		RESULT	ACTION TO TAKE
1	<b>VERIFY NOISE</b>  • Check for gear noise to verify if within normal range.	Noise within normal range	Normal condition.
		Noise not within normal range	GO to 2.
2	<b>LINKAGE CHECK</b>  • Check linkage for proper adjustment, wear or damage.		GO to 3.
			<b>SERVICE, REPLACE</b> and/or <b>ADJUST</b> linkage as required.
3	<b>FLUID CHECK</b>  • Check the fluid for proper level and/or contamination. ①	Fluid level within cross-hatched area at operating temperature	GO to 4.
		Fluid level beneath cross-hatched area	<b>ADD</b> specified fluid to bring level within cross-hatched area at operating temperature.
		Fluid contaminated	<b>DISASSEMBLE, CLEAN</b> and <b>SERVICE</b> transmission. <b>FLUSH</b> torque converter and cooler.
4	<b>STALL TEST</b>  • Perform the Stall Test as described under Stall Test in the Diagnosis and Testing portion of this section.	Noise stops	GO to 5.
		Noise doesn't stop	<b>EXAMINE</b> torque converter and pump. <b>SERVICE</b> or <b>REPLACE</b> as required. Also <b>CHECK</b> for loose torque converter to flywheel housing bolts or nuts.

① For definition of contamination, refer to Transmission Fluid Condition in the Diagnosis and Testing portion of this section.



TRANSMISSION NOISY — OTHER THAN VALVE RESONANCE (Cont'd.)		
TEST STEP	RESULT	ACTION TO TAKE
<b>5 NOISE CHECK</b>  • Run transmission in all gears and check for noise.	Noise doesn't stop in any gear	GO to 6.
	Noise stops in Low and R only	SERVICE forward planetary and/or one-way clutch.
	Noise stops in 2, HIGH and R only	SERVICE reverse planetary.
	HIGH only	SERVICE both planetaries.
<b>6 SPEEDOMETER GEAR</b>  • Remove the speedometer gear and check for noise.	Noise stops	REPLACE speedometer gear.
	Noise doesn't stop	CHECK extension housing bushing, seal or driveshaft. SERVICE or REPLACE as required.

## CLEANING AND INSPECTION

### Transmission Fluid Drain and Refill

Normal maintenance and lubrication requirements do not necessitate periodic automatic transmission fluid changes. If major service, such as a clutch band, bearing, etc., is required in the transmission, it will have to be removed for service. **At this time the converter, transmission cooler and cooler lines must be thoroughly flushed to remove any dirt.**

When used under continuous or severe conditions, the transmission should be drained and refilled with fluid as specified. Before adding fluid, be sure that the correct type will be used. If in doubt, check the Safety Standard Certification Label affixed to the left front door face panel or door pillar for the Transmission Code.

For A4LD Automatic Transmission (Code T), use fluid that meets Ford Specification, Motorcraft Mercon® Multi-Purpose Automatic Transmission Fluid XT-2-QDX or DDX (ESP-M2C166-H) or equivalent.

**CAUTION: Use of a fluid other than specified above could result in transmission malfunction and/or failure.**

When filling a dry transmission and converter, refer to Specifications for capacity. Check the fluid level following the room temperature checking procedures.

Procedures for partial drain and refill, due to in-vehicle service operation, are as follows.

- Loosen the pan attaching bolts to drain the fluid from the transmission.
- When all fluid has drained from the transmission, remove and thoroughly clean the pan. Discard pan gasket.
- Place a new gasket on the pan, and install pan on transmission.
- Add 2.8 liters (3 quarts) of fluid to transmission through the filler tube.
- Check the fluid level following the room temperature checking procedures.

If it is necessary to perform a complete drain and refill, it will be necessary to remove the residual fluid from the cooler lines and flush cooler lines completely.



## Transmission Fluid Lines

When one or more of the fluid cooler steel tubes must be replaced, each replacement tube must be fabricated from the same size steel tubing as the original line.

Using the old tube as a guide, bend the new tube as required. Add the necessary fittings, and install the tube. Make sure that the replacement tube has adequate clearance to other components, especially the exhaust system and parts having sharp edges.

After the fittings have been tightened, add fluid as needed, and check for fluid leaks.

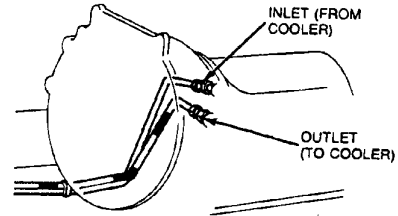

## Vacuum Tubes

Refer to the following illustration for vacuum tube installation.

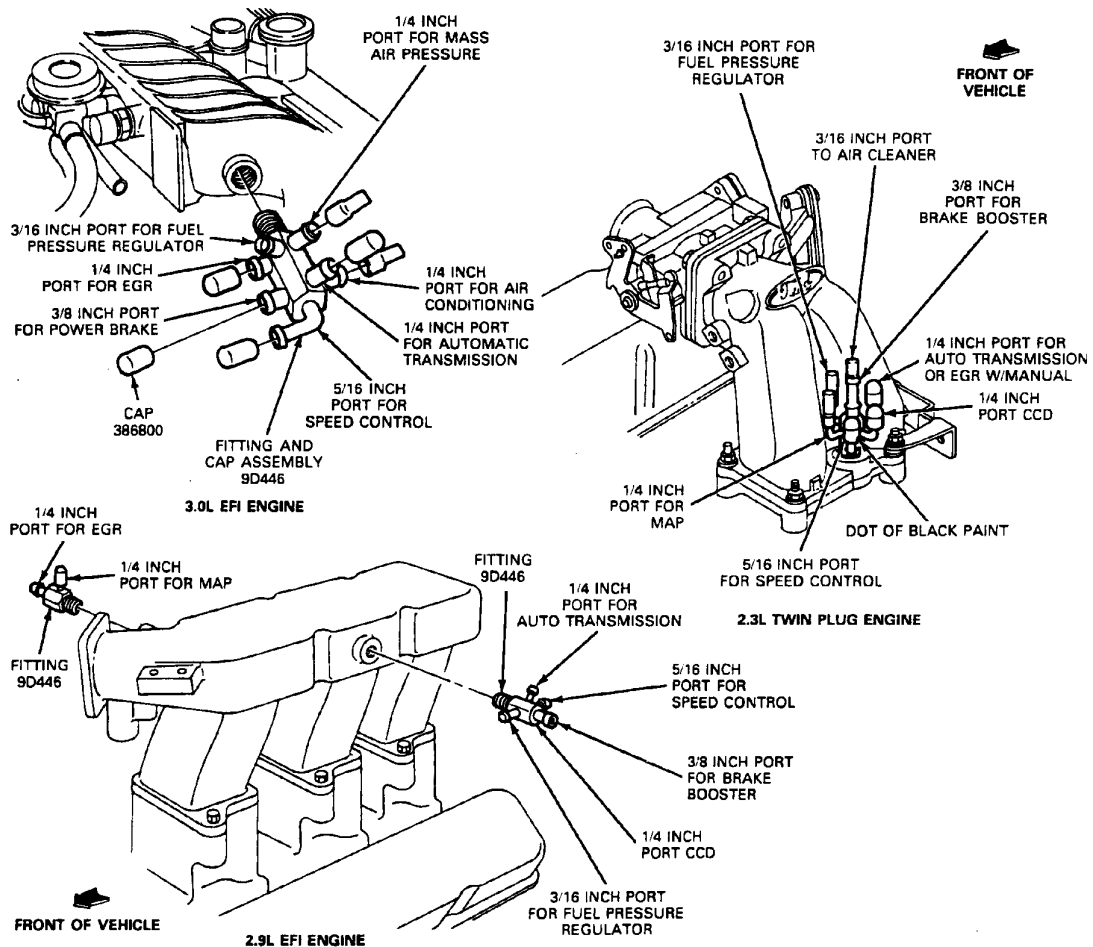

## Transmission

It is important to completely clean all transmission components, including converter, cooler, cooler lines, main control valve body, governor, all clutches, and all check balls after any transmission servicing that generates contamination. These contaminants are a major cause for recurring transmission troubles and must be removed from the system before the transmission is put back into service. The cleaning of debris from the direct clutch check ball is often omitted. This omission can lead to a repeat servicing of the transmission.

Clean the parts with suitable solvent and use moisture-free air to dry off all the parts and clean out fluid passages.

The composition clutch plates, bands and synthetic seals should not be cleaned in a vapor degreaser or with any type of detergent solution. To clean these parts, wipe them off with a lint-free cloth. New clutch plates or bands should be soaked in transmission fluid specified for that transmission type for fifteen minutes before being assembled.

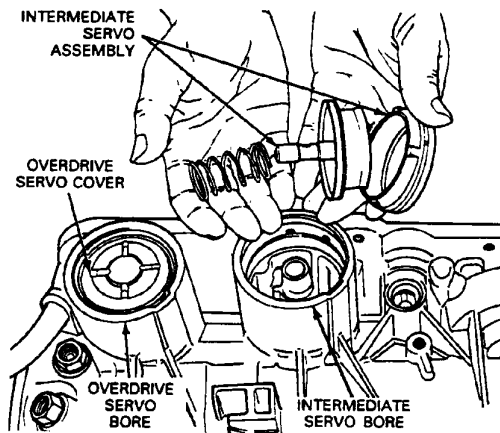

## Control Valve Body

1. Clean all parts thoroughly in clean solvent, and blow dry with moisture-free compressed air.
2. Inspect all valve and plug bores for scores. Check all fluid passages for obstructions. Inspect the check valve for free movement. Inspect all mating surfaces for burrs or distortion. Inspect all plugs and valves for burrs or scores. Use crocus cloth to polish valves and plugs. Avoid rounding the sharp edges of the valves and plugs with the cloth.
3. Inspect all springs for distortion. Check all valves and plugs for free movement in their respective bores. Valves and plugs, when dry, must fall from their own weight in their respective bores.
4. Roll the manual valve on a flat surface to check for bent condition.

## Overdrive and Intermediate Servos

1. Inspect the servo bore for cracks, the servo piston for damage, and the piston bore and servo piston stem for scores. Check fluid passages for obstructions. Replace damaged seals.
2. Check the servo spring and servo band strut(s) for distortion.
3. Inspect the cover seal and gasket cover sealing surface for damage.
4. Inspect the band lining for excessive wear and for proper bonding to the metal band.

NOTE: Identify servo covers, pistons, and springs with a tag for proper identification.

## Low-Reverse Servo

1. Inspect the bore for scores.
2. Check the fluid passages for obstructions.
3. Inspect the band for distortion. Inspect the band ends for cracks.
4. Inspect the servo spring for distortion.
5. Inspect the band lining for excessive wear and for proper bonding to the metal band.
6. Replace damaged cover seal.
7. Replace piston seals if damaged.

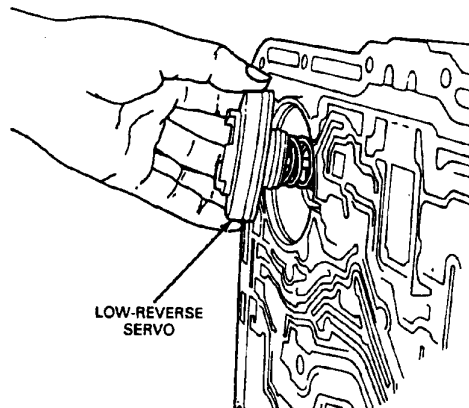

## Extension Housing

1. Inspect housing for cracks. Inspect gasket surface for burrs or warpage.

2. Inspect bushing for scores or wear. Replace if required.
3. Inspect the rear seal for hardness, cracks, or wear. If the seal shows wear or deterioration, replace the seal.
4. Inspect the seal counterbore and remove all burrs and scores with crocus cloth.
5. Check vent for obstructions.

### Governor

1. Inspect the governor valves and bore for scores. Minor scores may be removed from the valves with crocus cloth. Replace the governor if the valves or body is deeply scored.
2. Check for free movement of the valve in the bore. The valve should slide freely of its own weight in the bore when dry. Inspect fluid passages in the valve body and collector body for obstructions. **All fluid passages must be clean.**
3. Inspect the mating surfaces of the governor body and collector body for burrs and distortion. Mating surfaces must be smooth and flat.

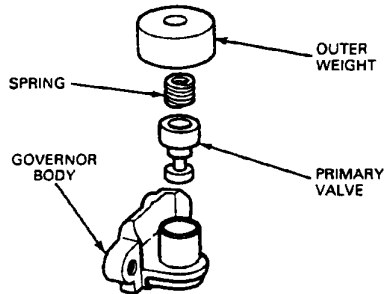

### Pump

1. Inspect mating surfaces of pump body and case for burrs.
2. Inspect the drive and driven gear bearing surface for scores and check gear teeth for burrs.
3. Inspect the front pump seal for cuts or nicks, and pump bushing for scoring.
4. Check fluid passages for obstructions.
5. If any parts are found damaged or worn, replace the pump as a unit. Minor burrs and scores may be removed with crocus cloth.

### Reverse-High and Overdrive Clutches

1. Inspect the drum band surface, bushing, and thrust surfaces for scores. Minor scores may be removed with crocus cloth. **Badly scored parts must be replaced.**
2. Inspect the clutch piston bore and the piston inner and outer bearing surfaces for scores.
3. Check the fluid passages for obstructions. All fluid passages must be clean and free of obstructions.
4. Inspect the clutch plates for wear, scoring, and fit on the clutch hub serrations. Replace all plates that are badly scored, worn, or do not fit freely in the hub serrations.
5. Inspect the clutch pressure plate for scores on the clutch plate bearing surface. Check the clutch release spring for distortion.
6. The clutch cylinders have check balls. Inspect the check balls for freedom of movement and proper seating.

### Forward Clutch

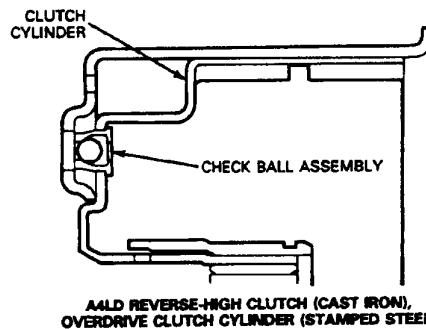
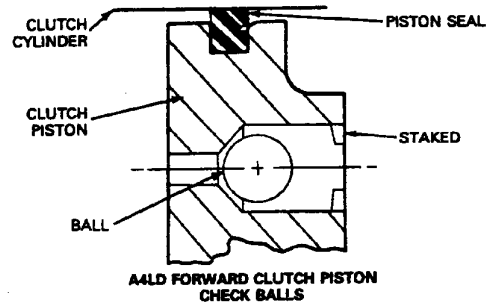

1. Inspect the clutch cylinder thrust surfaces, piston bore, and clutch plate serrations for scores or burrs. Minor scores or burrs may be removed with crocus cloth. Replace clutch cylinder if it is badly scored or damaged.

2. Check fluid pressure in the clutch cylinder for obstructions. Clean out all fluid passages. Inspect clutch piston for scores and replace if necessary. Inspect the piston check ball for freedom of movement and proper seating.
3. Check clutch release springs for distortion and cracks. Replace springs if they are distorted or cracked.
4. Inspect composition clutch plates, steel clutch plates, and clutch pressure plate for worn or scored bearing surface. Replace all parts that are deeply scored.
5. Check clutch plates for flatness and fit on the clutch hub serrations. Discard any plate that does not slide freely on the serrations or that is not flat.
6. Check clutch hub thrust surfaces for scores and clutch hub splines for wear.
7. Check input shaft for damaged or worn splines. Replace shaft if the splines are excessively worn. Inspect bushing in stator support for scores.

### Overdrive One-Way Clutch and Planetary Rear One-Way Clutch

1. Inspect outer and inner races for scores or damaged surface areas where rollers contact races.
2. Inspect rollers and springs for excessive wear or damage.
3. Inspect spring and roller cage for bent or damaged spring retainers.

### Converter and Fluid Cooler

When internal wear or damage has occurred in the transmission, metal particles, clutch plate material, or band material may have been carried into the converter and oil cooler. These contaminants are a major cause of recurring transmission troubles and **MUST** be removed from the system before the transmission is put back into service.

Whenever a transmission has been disassembled to replace worn or damaged parts or because the valve body sticks from foreign material, the converter, oil cooler and oil cooler lines **MUST** be cleaned and flushed by using the Rotunda Torque Converter Cleaner (model 014-00028) or equivalent. Under **NO** circumstances should an attempt be made to clean converters by hand agitation with solvent.

The lack of a drain plug in the A4LD converter increases the amount of residual flushing solvent retained in the converter after cleaning. This retained solvent is not acceptable and a method of diluting it is required. The following procedure is to be used after removal of the A4LD torque converter from the cleaning equipment.

1. **Thoroughly drain** remaining solvent through the converter hub.
2. Add 1.9L (2.0 U.S. quarts) of clean transmission fluid to the converter. Agitate by hand.
3. **Thoroughly drain** solution through the converter hub.

### Converter End Play and One-Way Clutch Check

The Converter One-Way Clutch Torquing Tool T77L-7902-B and D84L-7902-A One-Way Clutch Holding Tool or an equivalent fabricated holding tool are used to check the converter one-way clutch.

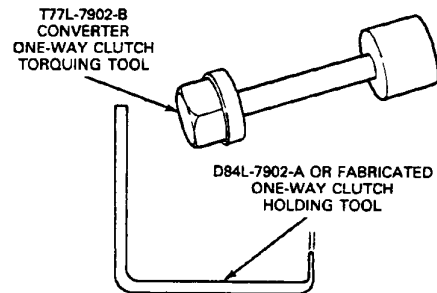

### End Play Check

1. Insert Torque Converter End Play Checking Tool, T80L-7902-A or equivalent into the converter impeller hub, until it bottoms.

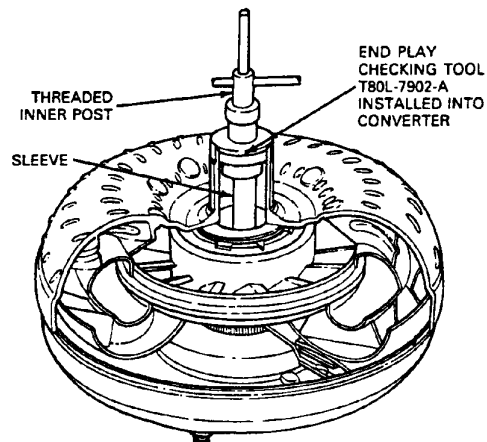

2. Expand sleeve in the turbine spline by tightening the threaded inner post until the tool is securely locked in the spline.

3. Attach Dial Indicator with Bracketry TOOL-4201-C or equivalent to the Torque Converter End Play Checking Tool T80L-7902-A or equivalent. Position the indicator button on the converter impeller housing, and set the dial face at 0 (zero).
4. Lift tool upward as far as it will go and note indicator reading. The indicator reading is the total end play which the turbine and stator share. Replace the converter unit if the total end play exceeds the limits. Refer to Specifications.
5. Loosen threaded inner post to free tool, and remove the tool from the converter.

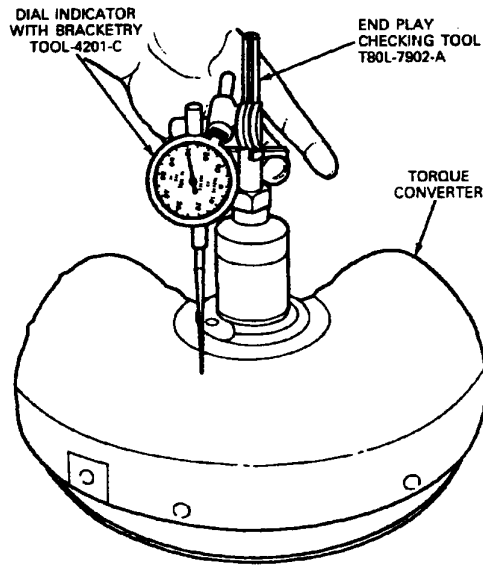

### Converter One-Way Clutch Check

1. Use One-Way Clutch Holding Tool, D84L-7902-A or equivalent or fabricate a one-way clutch holding tool as shown below.

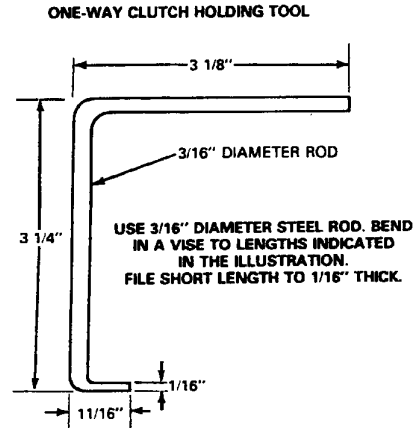

2. Insert one-way clutch holding tool in one of the grooves in the stator thrust washer.
3. Insert the Converter One-Way Clutch Torquing Tool, T77L-7902-B in the converter impeller hub so as to engage the one-way clutch inner race.
4. Attach a torque wrench to the one-way clutch torquing tool. With the one-way clutch holding tool held stationary, turn torque wrench counterclockwise. The converter one-way clutch should lockup and hold a 14 N-m (10 ft-lb) torque. The converter one-way clutch should rotate freely in a clockwise direction. Try the one-way clutch for lockup and hold in at least five different locations around the converter.
5. If the one-way clutch fails to lockup and hold at 14 N-m (10 ft-lb) torque, replace the torque converter.

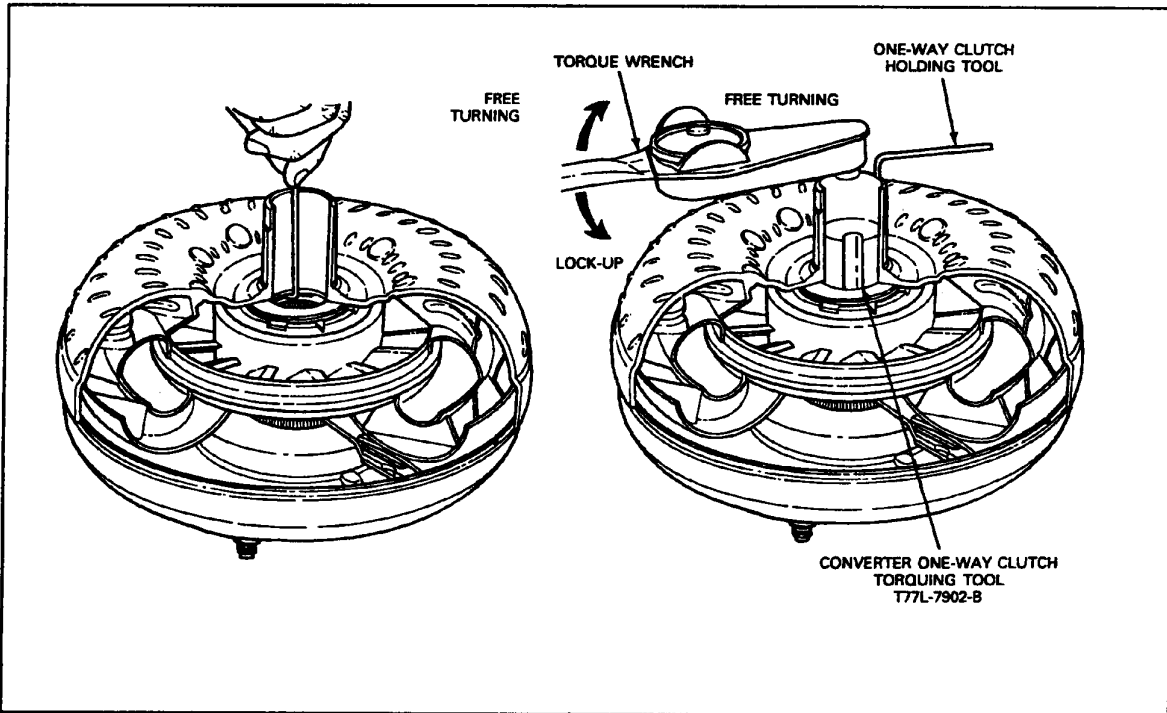

### Stator To Impeller Interference Check

1. Position front pump assembly on a bench with spline end of the stator shaft pointing up.
2. Mount a converter on the pump with splines on the one-way clutch inner race engaging the mating splines of the stator support. The impeller hub will then engage the pump drive gear.
3. Hold pump stationary and try to rotate the torque converter both clockwise and counterclockwise. The converter should rotate freely without any signs of interference or scraping within the converter assembly.
4. If there is an indication of scraping, the trailing edges of the stator blades may be interfering with the leading edges of the impeller blades. In such cases, replace the converter.

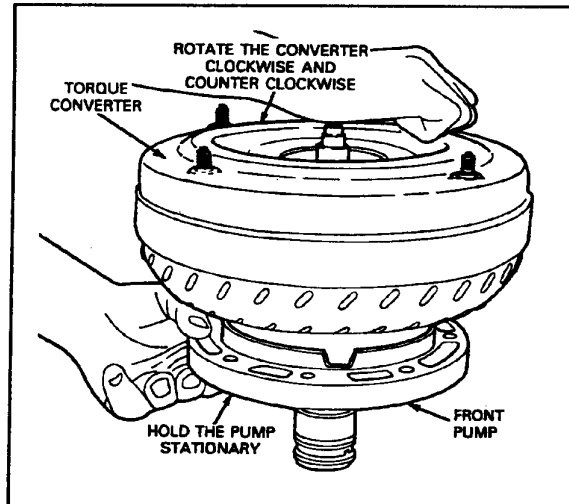

### Pinion Carriers

Individual parts of the planet carriers are not serviceable.



1. Check pins and shafts in planet assemblies for loose fit and/or complete disengagement. Use a new planet assembly if either condition exists. Before installing a planet assembly, the shaft retaining pins should be checked for adequate staking. If necessary, restake the pins before installation. When restaking, the retaining pins must not be driven into the carrier any further than 1.0mm (0.040 inch) below the surface of the carrier.
2. Inspect pinion gears for damaged or excessively worn teeth.
3. Check for free rotation of pinion gears.

### Stator Support

1. Inspect stator support splines for burrs and wear.
2. Check oil ring grooves in stator support for nicks, burrs or damaged edges.
3. Check front and rear bushings of stator support for wear or scoring.
4. Check front pump support seal.
5. Check seal rings for damage.

### Case

Inspect the case for cracks and stripped threads. Inspect the gasket surfaces and mating surfaces for burrs. Check the vent for obstructions, and check all fluid passages for obstructions and leakage.

Inspect the case bushing for scores. Check all parking linkage parts for wear or damage.

If a transmission case thread is damaged, service kits may be purchased from local jobbers. To service a damaged thread, the following procedures should be carefully followed:

1. Drill out the damaged threads, **using the same drill size as the thread outside diameter**. For example, use a 5/16 inch drill for a 5/16-18 thread.
2. Select the proper special tap and tap the drilled hole. The tap is marked for the size of the thread being repaired. Thus, the special tap marked 5/16-18 will not cut the same thread as a standard 5/16-18 tap. It does cut a thread large enough to accommodate the insert, and after the insert is installed, the original thread size (5/16-18) is restored.

3. Select the proper coil inserting tool. These tools are marked with the thread size being repaired. Place the insert on the tool and adjust the sleeve to the length of the insert being used. Press the insert against the face of the tapped hole. Turn the tool clockwise and wind the insert into the hole until the insert is 1/2 turn below the face.
4. Working through the insert, bend the insert tang straight up and down until it breaks off at the notch.
5. Improperly installed inserts can be removed with the extractor tool. Place the extractor tool in the insert with the blade resting against the top coil 1/4 to 1/2 turn away from the end of the coil. Tap the tool sharply with a hammer until the blade cuts into the insert. Exert downward pressure on the tool and turn it counterclockwise until the insert is removed.

## REMOVAL AND INSTALLATION

### Transmission

#### Removal

1. Disconnect the battery negative cable.
2. Raise the vehicle on a hoist.
3. Place a drain pan under the transmission fluid pan. On Explorer vehicles, pry the lower clips of transmission heat shield back slightly to allow access to pan bolts. Starting at the rear of the pan and working toward the front, loosen the attaching bolts and allow the fluid to drain. Then remove all of the pan attaching bolts except two at the front, to allow the fluid to further drain. After all the fluid has drained, install two bolts on the rear side of the pan to temporarily hold it in place.
4. Remove the converter access cover from the converter housing. Remove one (1) bolt on the access cover of 6 cylinder applications (3.0L) pivot / swing cover open.
5. Remove the starter-to-converter housing attaching bolts and position the starter out of the way.  
**NOTE:** On 2.9L and 4.0L engines, the converter attaching nuts are accessed through the starter motor mounting hole. On 2.3L engines, the converter attaching nuts are accessed through the cover on the engine oil pan.
6. Remove the four flywheel-to-converter attaching nuts by placing a 22mm socket and breaker bar on the crankshaft pulley attaching bolt. Rotate the pulley clockwise (as viewed from the front) to gain access to each of the nuts.

**CAUTION:** On 2.3L belt driven overhead cam engines, never rotate the pulley in a counterclockwise direction (as viewed from the front).

7. Scribe a mark indexing the driveshaft to the rear axle flange. Remove the driveshaft

install the extension housing seal replacer tool in the extension housing.

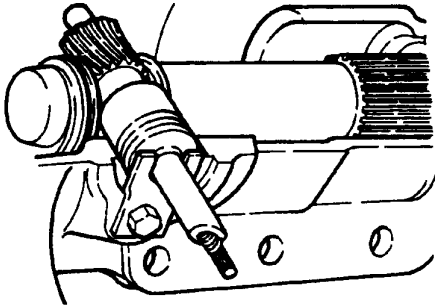

8. Remove the speedometer cable from the extension housing.
9. Disconnect the shift rod at the transmission manual lever. Remove the kickdown cable from the ball stud lever. Depress the tab on the cable downshift retainer and remove the cable from the bracket.
10. Disconnect the neutral start switch wires and the converter clutch solenoid connector.
11. Remove the vacuum line from the transmission vacuum modulator.
12. Position a transmission jack under the transmission and raise it slightly.
13. Remove the engine rear support-to-crossmember bolts.
14. Remove the crossmember-to-frame side support attaching bolts and remove the crossmember insulator and support and damper.

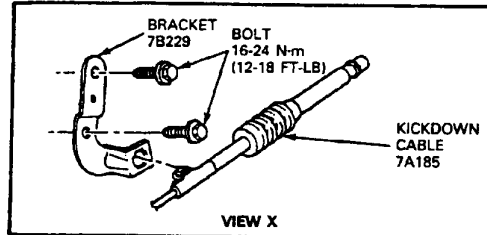
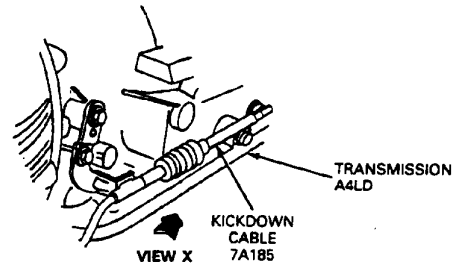

15. Lower the jack under the transmission and allow the transmission to hang.
16. Position a jack to the front of the engine and raise the engine to gain access to the two upper converter housing-to-engine attaching bolts on Ranger and Explorer vehicles.
17. Disconnect the oil cooler lines at the transmission. Plug all openings to keep out dirt.
18. Remove the lower converter housing-to-engine attaching bolts.
19. Remove the transmission filler tube.
20. Secure the transmission to the jack with a safety chain.
21. Remove the two upper converter housing-to-engine attaching bolts. Move the transmission to the rear so it disengages from the dowel pins and the converter is disengaged from the flywheel. Lower the transmission from the vehicle.



**NOTE:** If the transmission is to be removed for a period of time, support the engine with a safety stand and wood block.

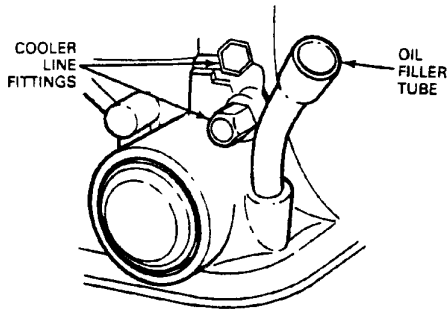

### Installation

1. Position the converter to the transmission making sure the converter hub is fully engaged in the pump gear. To accomplish this, push and rotate the converter until two (2) "bumps" are felt. Keep pushing and rotating until dimension "A" shown below, is reached.

**NOTE:** Make sure the torque converter rotates freely and is not bound up.

Dimension "A" should be:

Minimum: 10.23mm (7 / 16 in)

Maximum: 14.43mm (9 / 16 in)

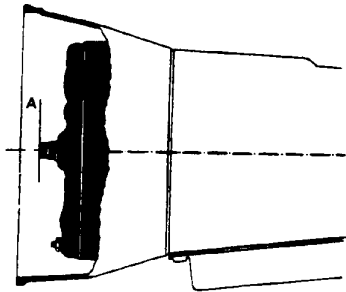

2. With the converter properly installed, place the transmission on the jack and secure with a safety chain.
3. Rotate the converter so the drive studs are in alignment with their holes in the flywheel.
4. With the transmission mounted on a transmission jack, move the converter and transmission assembly forward into position being careful not to damage the flywheel and the converter pilot.

**During this move, to avoid damage, do not allow the transmission to get into a nose down position as this will cause the converter to move forward and disengage from the pump gear. The converter housing is piloted into position by dowels in the rear of the engine block. The converter must rest squarely against the flywheel. This indicates that the converter pilot is not binding in the engine crankshaft.**

5. Install two (2) converter housing-to-engine attaching bolts at the engine dowel locations. Tighten to 38-51 N-m (28-38 ft-lb).
6. Install the remaining converter housing-to-engine attaching bolts and tighten to 38-51 N-m (28-38 ft-lb).
7. Remove the safety chain from the transmission.
8. Insert the filler tube in the stub tube and secure it to the cylinder block with the attaching bolt. Tighten the bolt to 38-51 N-m (28-38 ft-lb). If the stub tube is loosened or dislodged, it should be replaced.
9. Install the oil cooler lines in the retaining clip at the cylinder block. Connect the lines to the transmission case.
10. Remove the jack supporting the front of the engine.
11. Raise the transmission. Position the crossmember, insulator and support and damper to the frame side supports and install the attaching bolts. Tighten the bolts to 27-41 N-m (20-30 ft-lb).
12. Lower the transmission and install the rear engine support-to-crossmember nut. Tighten the bolt to 82-108 N-m (60-80 ft-lb).
13. Remove the transmission jack.
14. Install the vacuum hose on the transmission vacuum unit. Install the vacuum line into the retaining clip.
15. Connect the neutral start switch plug to the switch. Install the converter clutch / 3-4 shift solenoid connector.
16. Install the four flywheel-to-converter attaching nuts.  
When assembling the flywheel to the converter, first install the attaching nuts and tighten to 27-46 N-m (20-34 ft-lb).
17. Install the converter access cover and adapter plate bolts. Tighten the bolts to 16-22 N-m (12-16 ft-lb). On 2.3L engines, tighten the oil pan access cover bolts to 2.5-3.6 N-m (22-32 in-lb).
18. Install the starter and tighten the attaching bolts to 20-27 N-m (15-20 ft-lb).
19. Connect the muffler inlet pipe to the exhaust manifold if disconnected for removal.

20. Connect the transmission shift rod to the manual lever.
21. Connect the downshift cable to the downshift lever.
22. Install the speedometer cable as described in Section 13-02, Speedometer / Odometer.
23. Install the driveshaft so the marks scribed on the driveshaft and rear axle flange are in alignment. Tighten the companion flange U-bolt attaching nuts to 95-130 N-m (70-95 ft-lb).
24. Adjust the manual and downshift linkage as required.
25. Lower the vehicle. Connect the battery negative cable. Fill the transmission to the proper level with the specified fluid.  
  
Pour in five quarts of fluid; then run the engine and add fluid as required.
26. Check the transmission, converter assembly and oil cooler lines for leaks.

5. Push vacuum diaphragm into case and secure with retaining clamp and bolt. Tighten bolt to 9-12 N-m (80-106 in-lb).
6. Install vacuum diaphragm hose to vacuum diaphragm.

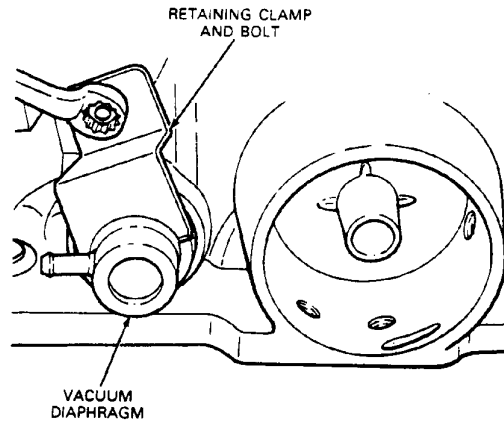

### Vacuum Diaphragm

#### Removal and Installation

1. Disconnect hose from vacuum diaphragm.
2. Remove vacuum diaphragm retaining bolt and clamp. **Do not pry or bend clamp.** Pull vacuum diaphragm from transmission case.
3. Remove the vacuum diaphragm control rod from transmission case.
4. Install vacuum diaphragm control rod in transmission case.

### Control Valve Body

#### Removal

1. Raise vehicle on a hoist so transmission and pan is accessible.
2. Loosen pan attaching bolts and drain fluid from transmission. **If the same fluid is to be used again, filter through a 100 mesh screen. Reuse fluid only if it is in good condition.**
3. Remove transmission fluid pan attaching bolts, pan and gasket.
4. Remove filter screen and O-rings.
5. Remove low-reverse servo cover, piston, spring and gasket.
6. Disconnect two wires at the converter clutch solenoid and the two wires at the 3-4 shift solenoid.

- Remove bolts from the control valve body. **Note that the bolts are of different lengths and their locations are different from the bolt locations on other automatic transmissions. Carefully ease the body from the case while unlocking and detaching the selector lever connecting rod.**

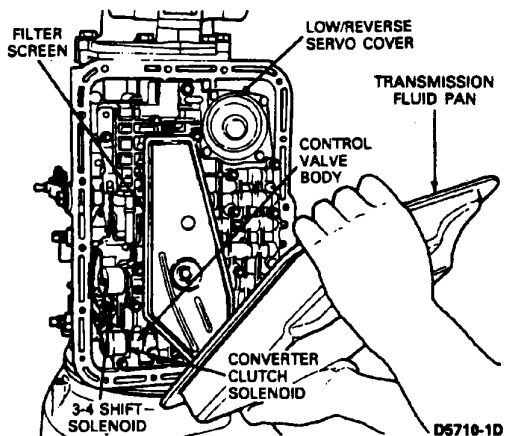

### Installation

- Clean and inspect the valve body prior to installation, as detailed in this section.

- Attach and lock the selector lever connecting rod (Z-Link) to the manual valve and ease control body into the case.  
**CAUTION: Use care not to bend selector lever connecting rod (Z-Link).**
- Insert correct length bolts, finger-tight, in holes A and B to position control body to case.
- Insert all remaining bolts (correct length) except filter screen bolt and tighten to specification.
- Remove the bolt from hole A and install detent spring to bolt, then reassemble and tighten A and B locations to specification.
- Install low-reverse servo cover, piston, spring and gasket.
- Connect the converter clutch solenoid wires.
- Clean filter screen with solvent. Then install filter screen O-ring and filter screen.
- Using a new gasket, install fluid pan. Tighten retaining bolts to 11-13.5 N·m (8-10 ft·lb).
- Lower vehicle and fill transmission with proper grade and quantity of fluid.  
Pour in 2.8L (3 quarts) of fluid. Run engine and add fluid as required.
- Operate vehicle and check for leaks.

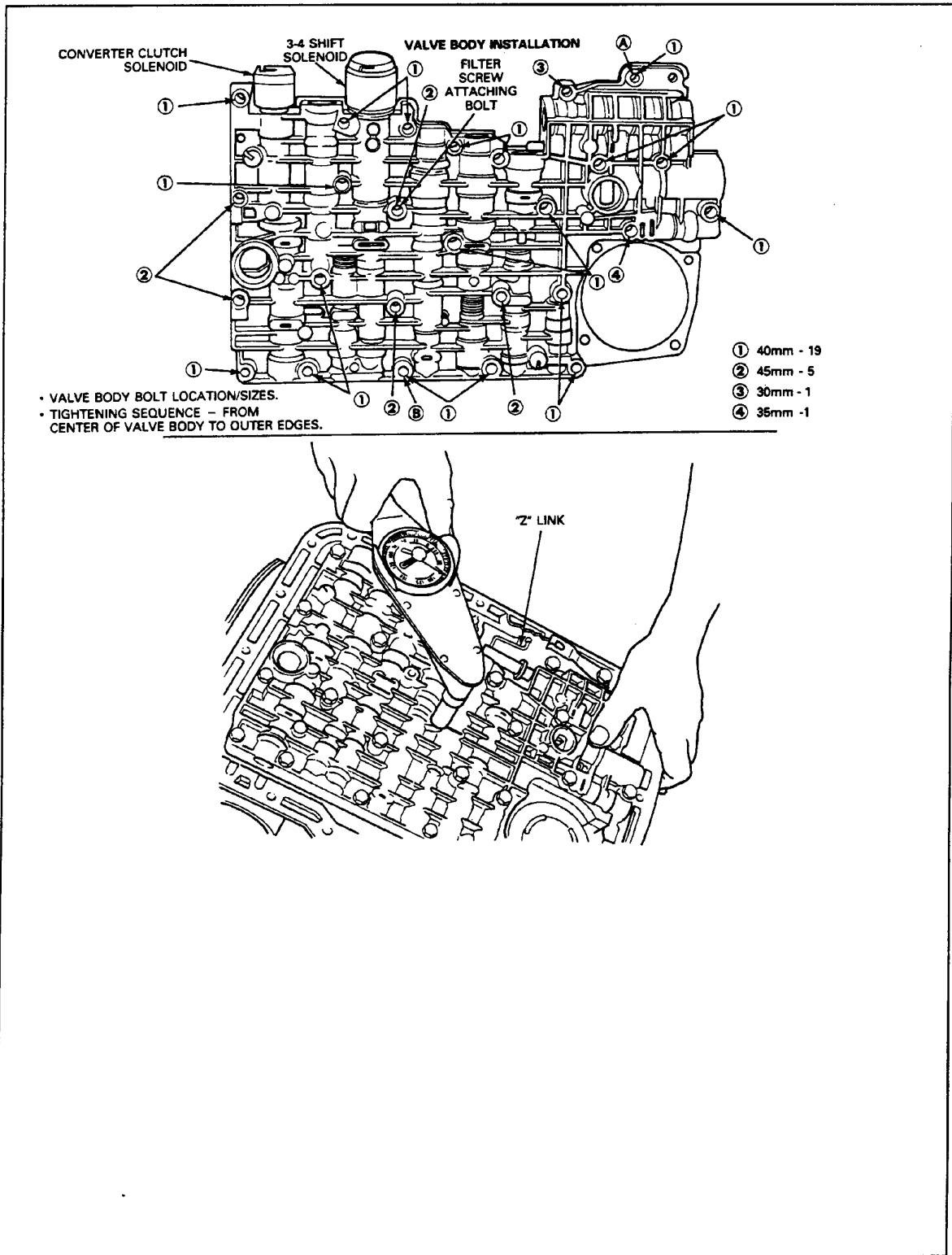

## Low-Reverse Servo

### Removal

1. Raise vehicle on a hoist.
2. Place a drain pan under transmission fluid pan. Starting at rear of pan and working toward front, loosen attaching bolts and allow fluid to drain. Remove all of the pan attaching bolts except two at the front to allow fluid to further drain. Finally remove all of bolts and remove the pan.
3. Remove oil filter screen and gasket.
4. Remove retaining screws, low-reverse servo cover, piston, spring and gasket.

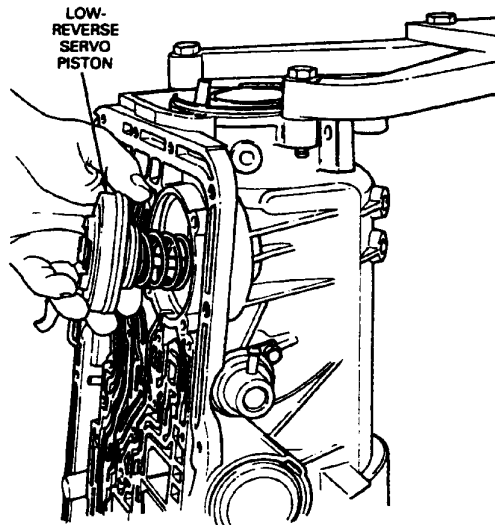

### Installation

1. Install low-reverse servo piston and spring in the servo housing.
2. Install servo cover and gasket.
3. Clean and replace filter screen and gasket.
4. Position transmission fluid pan and a new gasket. Install retaining screws in two steps.
5. Refill transmission with the proper grade and quantity of fluid.  
Pour in 2.8L (3 quarts) of fluid. Run engine and add fluid as required.
6. Operate vehicle and check for leaks.

## Extension Housing Oil Seal

### Removal and Installation

1. Raise vehicle on a hoist.
2. Remove driveshaft. Driveline General Service. Make scribe marks on driveshaft end yoke and rear axle companion flange to assure proper positioning of driveshaft during assembly.
3. Remove oil seal using Extension Housing Seal Remover T71P-7657-A or equivalent.
4. Remove extension housing bushing using Extension Housing Bushing Remover T77L-7697-E or equivalent.
5. Install new extension housing bushing using Extension Housing Bushing Replacer T77L-7697-F or equivalent.
6. Before installing a new seal, inspect the sealing surface of the universal joint yoke for scores. If scoring is found, replace yoke.

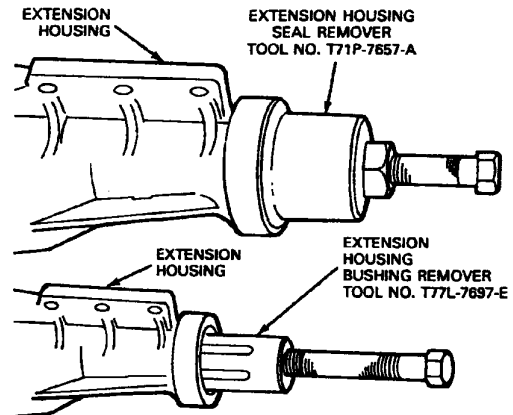

7. Inspect counterbore of housing for burrs. Remove any burrs with crocus cloth.
8. Install new oil seal using Extension Housing Seal Replacer T74P-77052-A or equivalent. Coat inside diameter at the end of the rubber boot portion of seal with Long-Life Lubricant C1AZ-19590-BA (ESA-M1C75-B) or equivalent. Coat the front universal joint spline with Long-Life Lubricant C1AZ-19590-BA (ESA-M1C75-B) or equivalent.
9. Install driveshaft using scribe mark as a guide to assure correct balance.

10. Lower vehicle and check oil level in transmission.  
Add oil if necessary.

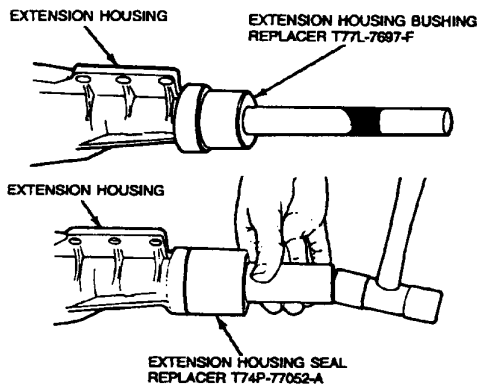

## Extension Housing

### Removal

1. Raise vehicle on a hoist.
2. Remove driveshaft. Make scribe marks on driveshaft end yoke and rear axle companion flange to assure proper positioning of driveshaft during assembly.
3. Support transmission with a transmission jack.
4. Remove speedometer cable from extension housing.
5. Remove rear support-to-crossmember attaching bolts or nuts.
6. Raise transmission slightly and remove rear support from extension housing.
7. Loosen extension housing bolts and allow the transmission fluid to drain.
8. Remove bolts and extension housing.

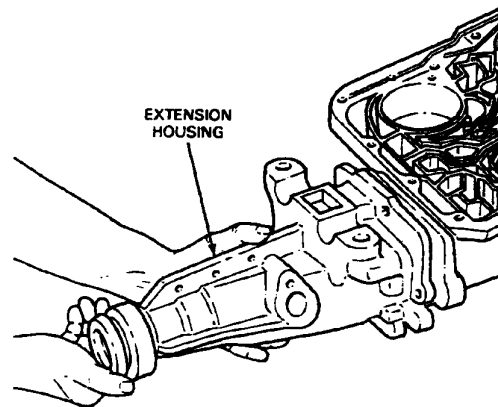

### Installation

1. Clean and inspect extension housing as outlined.
2. Install a new extension housing gasket on case.
3. Verify that park pawl and park pawl return spring are installed properly in extension housing and are preloaded.

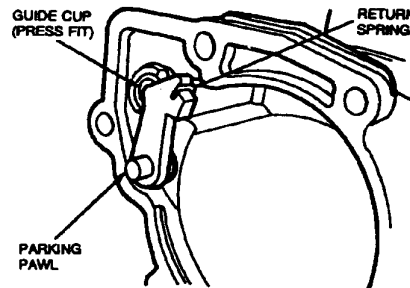

4. Position extension housing on the case, making sure to correctly seat the park pawl actuating rod in the guide cup bore in extension. Install the retaining bolts. Tighten bolts to 37-52 N-m (27-39 ft-lb).
5. Install rear support and lower transmission.
6. Install attaching bolts. Remove the transmission jack.
7. Install the speedometer cable as described in Section 13-02, Speedometer / Odometer.
8. Install driveshaft using scribe mark as a guide to assure correct balance.
9. Lower vehicle and fill transmission with fluid, adding as required while running engine.

10. Check extension housing area for fluid leaks.

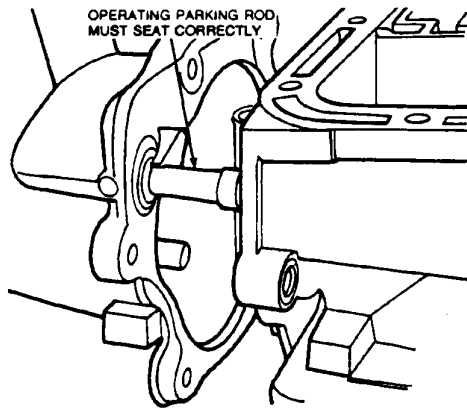

2. Position governor body over the oil feed holes of the oil collector body.
3. Install governor body to oil collector body attaching bolts and tighten to specification.
4. Install extension housing as outlined.

## DISASSEMBLY AND ASSEMBLY

**NOTE:** Before beginning the transmission overhaul, review the following guidelines. These general rules are provided to emphasize the need for attention to detail and care when servicing an automatic transmission.

- If the transmission is being removed for major overhaul, it is important to completely clean all transmission components including converter, cooler, cooler lines, main control valve body, governor, all clutches, and all check balls after any transmission servicing that generates contamination. These contaminants are a major cause of recurring transmission troubles and must be removed from the system before the transmission is put back into service.
- Thorough cleaning of the transmission exterior will reduce the possibility that damaging contaminants might enter the sub-assemblies during disassembly and assembly.
- All fasteners must be tightened to specification.
- When building up sub-assemblies, each component part should be lubricated with clean transmission fluid. It is also good practice to lubricate the sub-assemblies as they are installed in the case.
- Needle bearings, thrust washers and seals should be lightly coated with petroleum jelly during sub-assembly buildup or transmission assembly.
- Many components and surfaces in the transmission are precision machined. Careful handling during disassembly, cleaning, inspection and assembly can prevent unnecessary damage to machined surfaces.
- When building up sub-assemblies or assembling the transmission, always use new gaskets and seals.
- The transmission service area should be kept clean, well organized and supplied with clean lint-free shop cloths.
- Whenever a seal is removed from a piston, shaft or servo, note the type of seal and when applicable, the direction of the sealing lip.
- Always use the specified transmission fluid when lubricating seals or other components prior to assembly. Refer to Specifications.

### Governor

#### Removal

1. Remove extension housing as described.
2. Remove governor body to oil collector body attaching bolts.
3. Remove governor body, valve, spring and weight from collector body.

**NOTE:** Components are not retained once the governor body to oil collector body attaching bolts have been removed. It is therefore necessary to hold the governor body and components while removing or installing.

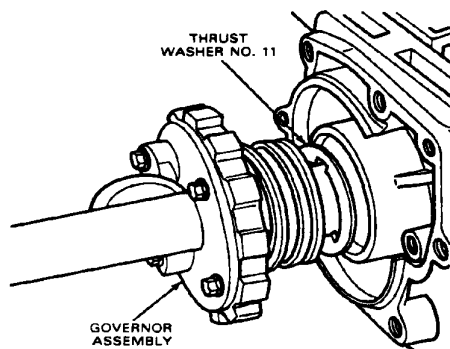

#### Installation

1. Assemble governor body and components.

4.0L Engines

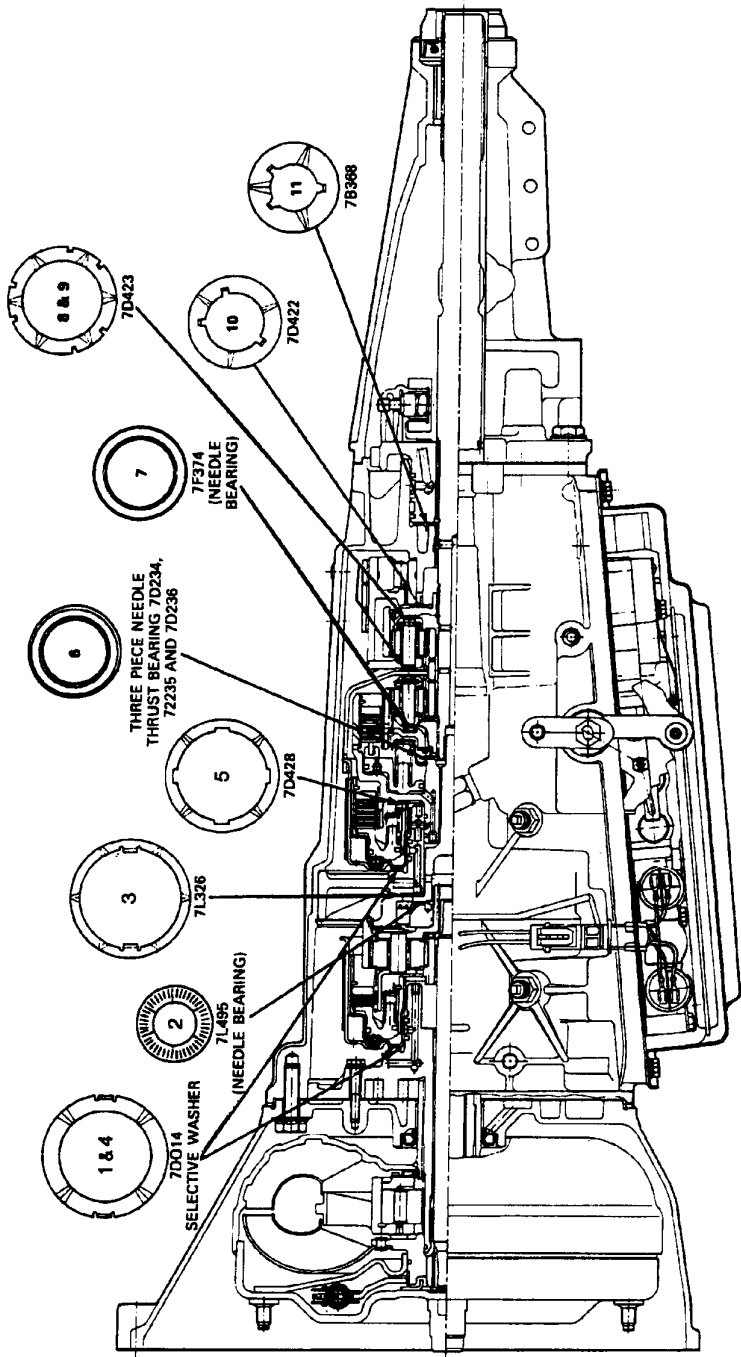

THRUST WASHER LOCATION AND IDENTIFICATION  
A4LD TRANSMISSION 4.0L ENGINES



2.3L, 2.9L and 3.0L Engines

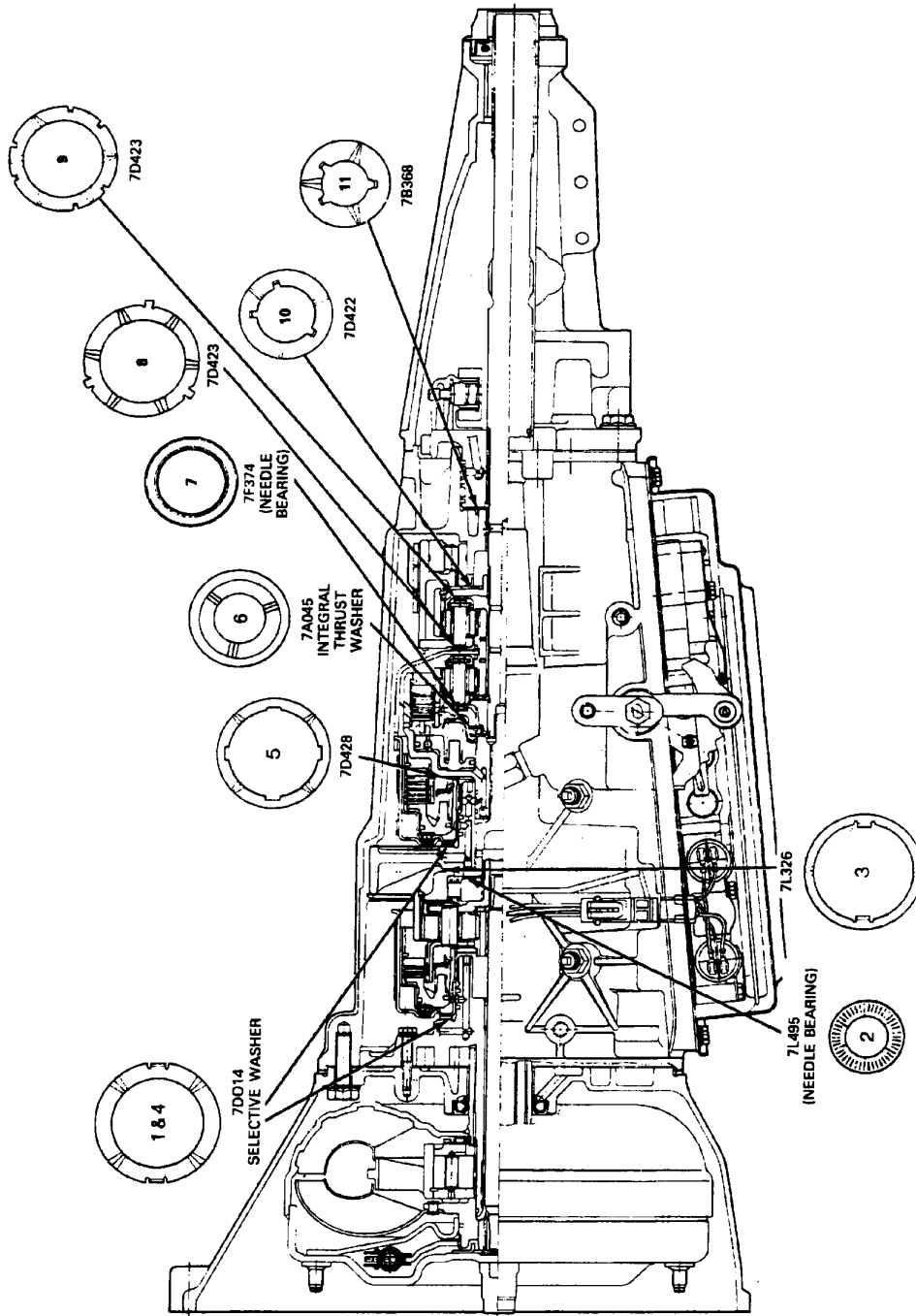

THRUST WASHER LOCATION AND IDENTIFICATION  
A4LD TRANSMISSION 2.3L, 2.9L AND 3.0L ENGINES

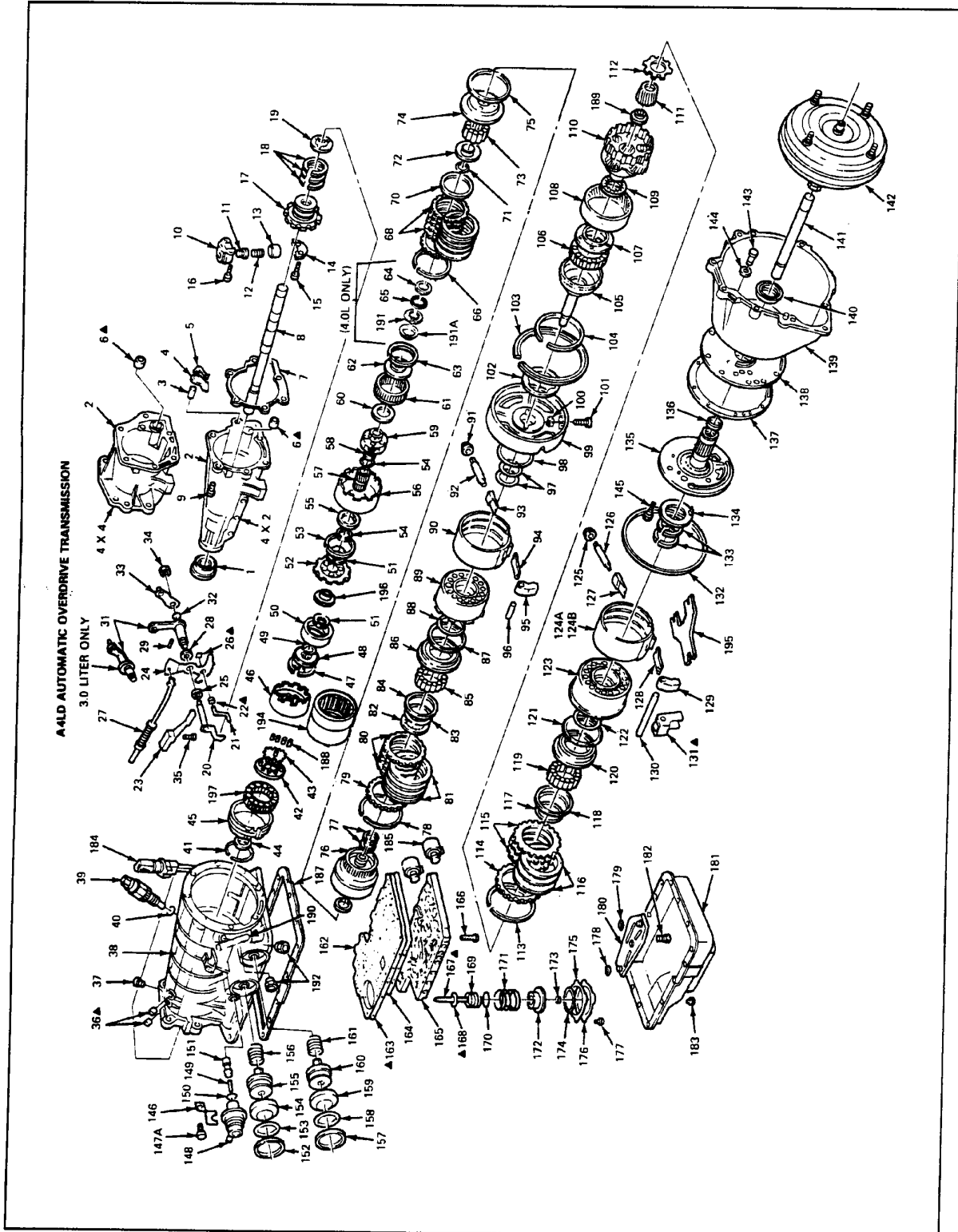



# Technical Service Information

## KEY TO EXPLODED VIEW — A4LD TRANSMISSION

Ref. No.	Basic Part No.	Description	Ref. No.	Basic Part No.	Description	Ref. No.	Basic Part No.	Description
1	7052	Seal Assy (Ext. Hsg.) Oil	41	E860120-S	Ring — Retaining 4.0L	80	78442	Plate (Clutch) High
2	7A039	Housing (Ext.)	42	7D181	Retainer — Overrun Cl. Spring 2.3L, 2.9L & 3.0L	81	7B164	Plate Assy. (Clutch) High
3	7D071	Shaft (Parking Pawl)	43	7D170	Spring — Overrun Clutch 2.3L, 2.9L & 3.0L	82	7D428	Washer (Intern. Brake Drum Thrust) — #5
4	7A441	Pawl (Parking)	44	7D422	Washer (O.P. Shaft Hub Thrust #10)	83	E860125-S	Ring 63 mm (High Cl. Pist. In Int. Bk. Drum)
5	7D070	Spring (Parking Pawl Return)	45	7D085	Band Assy. — Reverse	84	7D041	Ret. (Rev. Clutch Piston Spring) — 8 Tabs
6	7D419	Cup — Parking Rod Guide	46	7C498	Drum Assy. (Rev. Brake) 2.3L, 2.9L & 3.0L	85	7C151	Spring (Rev. Clutch Piston) 20 Req'd
7	7096	Gasket (Ext. Hsg.)	47	E860122-S	Ring 87 mm Retain Forward Ring Gear to Hub	86	7A256	Piston (Rev. Clutch)
8	7060	Shaft Assy (Output) 4.0L Vehicle Shaft Has no Lubr Hole	48	7D164	Hub — Output Shaft — 57 Ext — 34 In Teeth	87	7A548	Seal (Clutch Piston Oil)
9	E800152-S72	Screw — Extension to Case	49	E861125-S	Retaining Ring 25 x 1.2	88	7D404	Seal (High Clutch Piston Inner)
10	7A300	Body — Gov. Valve	50	7A153	Gear — Output Shaft Ring	89	7D044	Drum Assy (Intern. Brake)
11	7C034	Valve (Governor Primary)	51	7D423	Washer — Planet Carrier Thrust — (2 Req'd) #8 and #9	90	7D034	Band Assy (Intern. Servo)
12	7A302	Spring (Governor Valve)	52	7D006	Planet Assy (Rev.)	91	388307-S100	Screw (Rev. Band Adj.)
13	7D324	Weight — (Governor Outer)	53	E860119-S	Ring (Planet to Drum) Except 4.0L	92	7C482	Shaft (Intern. Bk. Band Anchor)
14	7F124	Counterweight — Governor	54	E860121-S	Ring — 39 mm (Input Shell to Sun Gr. Assy.) — (2 Req'd)	93	7D430	Shaft (Intern. Bk. Band Apply)
15	E602164-S72	Boil (Gov. Body to Collector Body) — (2 Req'd)	55	7D066	Washer (Input Shell Thrust) Except 4.0L	94	7D029	Lever (Intern. Band Servo)
16	E800156-S	Boil — M6 x 20 (Gov. Body to Collector Body) — 2 Req'd	56	7D064	Shell (Input)	95	7D396	Shaft (Intern. Band Act. Lever)
17	7D220	Body (Gov. Oil Collector)	57	7D063	Gear Assy (Sun)	96	7D433	Seal Ring (High Clutch) 2 Req'd — Vion
18	7D011	Ring (Gov. Hsg. Seal) — (3 Req'd)	58	7D235	Big. Thrust — Sun Gear Race — RR	97	7D429	Washer (Fri. Pump Input Thrust) — Sel. Fil. — #4
19	7B368	Washer (Output Shaft Thrust Gr. — #11)	59	7A398	Planet Assy (Fwd)	98	7D014	Support Assy — Center O/D Nut & Cage Assy S/L Mtl. M6
20	7D261	Lever Assy — Dwn/Shift Det. — Inner	60	7C374	Big. Assy. — Cl. Int. Drum Thrust — #7	100	E804373	Screw Cap — Hex 8.8 M6 x 15
21	7E333	Pin — Man. Vlv. Det. Lever — Inner	61	7D392	Gear (Ring Fwd) 72 Ext. 57 In. Teeth	101	71326	Washer (Center Support Thrust) — #3
22	E630020-S	Washer — Flat Steel	62	7C393	Hub (Fwd Ring Gear)	102	E860066-S	Ring Retaining (Retain 76033 In Case) Except 4.0L
23	7E332	Spring Assy — Man. Vlv. Detent	63	E860122-S	Ring — Ret 87 mm (Fwd. Ring Gr. to Hub)	105	7A656	Shaft — Center Assy — O/D
24	7C484	Lever — Manual Valve	64	7D235	Washer (Fwd. Cyl. Hub Thrust)	106	7C109	Clutch Assy — Overrun — O/D
25	E820112-S	Nut (Lvr. to Lev. Assy Dwn/Shift Det. Inlet)	65	7D234	Needle Thrust Bearing #6	107	71339	Washer — Over Clutch — O/D
26	E662312-S	Clip — Rod Retaining	66	E860115-S	Ret. Ring (Sel. Fil)	108	7653	Gear — O/D Ring
27	7D410	Pod Assy — Park Pawl Adju.	67	7B066	Plate (Clutch Pressure)	109	71495	Big. Assy — O/D Inner Race — #2
28	7B498	Seal Assy — Main Control Lvr. Oil	68	7B442	Plate (Clutch) Forward	110	7B446	Center Assy — Pl. Gear — O/D
29	E840125-S	Pin — Spring Roller (Retain Outer Man. Lvr. Assy)	69	7B164	Plate Assy — Clutch (Fwd)	111	7D063	Gear Assy — Sun O/D
31	7A256	Lever Assy — Manual Control	70	7E457	Spring — Forward Clutch Cushion	112	7660	Adapter — O/D Clutch
32	386078-S	O Ring — Outer Man. Lvr. Shaft Oil	71	E860109-S	Ring 34 mm (Hub to Fwd. Ring Gear)	113	E860126-S	Ring — Retaining (Sel. Fil)
33	7A394	Lever Assy — Dwn/Shift Ctrl — Outer	72	7C411	Ret (Fwd. Cl. Piston Spring)	114	7B006	Plate — O/D Clutch Pressure
34	E820109-S72	Nut — Hex M8 x 1 (Outer Man. Lvr. to Shaft)	73	7C151	Spring — Fwd Cl. Piston (15 Req'd)	115	7B442	Plate — O/D Clutch
35	E800185-S72	Screw M6 x 30 (Valve Body to Case)	74	7A262	Piston Assy (Fwd. Clutch)	116	7B164	Plate Assy — O/D Clutch Int. Spline
36	E840115-S	Pin — Rev. Band Anchor (2 Req'd)	75	7A548	Seal (Clutch Piston Oil)	117	E860125-S	Ring — Ret. 63 mm (O/D Cl. Pist. to O/D Bk. Drum)
37	7034	Vent Assy — Case	76	7D424	Cyl. Assy. (Fwd. Clutch)	118	7D041	Retainer — O/D Cl. Pist. Spring — 8 Tabs
38	7005	Case Assembly	77	7D019	Seal (Fwd Clutch Cyl.) — 2 Req'd	119	7C151	Spring — O/D Cl. Piston (20 Req'd)
39	7A247	Switch Assy — Gr. Shift Neutral	78	E860126-S	Ret Ring (Select Fil)	120	7A258	Piston — O/D Clutch
40	E853116-S	Seal — O Ring	79	7B066	Plate (Clutch Press) Rev.			

All light trucks transmissions use (4) E800152-S72 Screws and (2) E804137-S72 Studs.



# Technical Service Information

KEY TO EXPLODED VIEW — A4LD TRANSMISSION (Cont'd.)

Ref. No.	Basic Part No.	Description	Ref. No.	Basic Part No.	Description	Ref. No.	Basic Part No.	Description
121	7A548	Seal — O/D Cl. Piston — Outer	146	7E458	Clamp — TV Control Diaphragm	174	7423	Seal — Rev. Brd. Servo Ret. Oil — Large
122	7D404	Seal — O/D Cl. Piston — Inner	147	E800341-S72	Boil M6 x 12 mm (Valve Clamp to Case)	175	7L173	Gasket — Rev. Servo Sep. Plate Cover
123	7L669	Drum Assy — O/D	147A	E804533-S	Stud-M6 x M6 x 12.0 (2.9L 4x4 and all 4.0L)	176	7D036	Cover — Rev. Brd. Servo Piston
124A	7D034	Band Assy — O/D, 2.3L, 2.9L, 3.0L	148	7A377	Diaphragm Assy — TV Control	177	E800156-S72	Bot M6 x 20 (Rev. Servo to Vw. Bdy.) 4 Req'd
124B	7F196	Band Assy — O/D 4.0L (not shown)	149	7A380	Rod — TV Control	178	E863137-S	Offring — Oil Screen Assy — Small
125	388307-S100	Nut & Seal — Hex	150	E863110-S	Offring — Throttle Valve	179	E863132-S	Offring — Oil Screen Assy — Large
126	7C492	Screw — O/D Band Adj.	151	7D080	Valve — Throttle Control	180	7A088	Screen Assy — Oil Pan
127	7D430	Shut — O/D Brk. Drum Anchor	152	E8680343-S	Ring — Ret. 67 x 15 Intermediate	181	7A264	Oil Pan
128	7D028	Shut — O/D Brk. Drum Apply 2.3L, 2.9L & 3.0L	153	E863170-S	O-Ring — Servo Cover to Case — Intern.	182	E800154-S72	Screw — M6 x 45 (Vw. Bdy. to Case) 5 Req'd
129	7D396	Lever — O/D Band Servo	154	7L493	Cover & Seal Assy. Inter. Band Servo	183	E800158-S72	Screw — M8 x 14 (Oil Pan to Case) 18 Req'd
130	7D433	Shaft — O/D Band Adj. Lever	155	7E221	Piston & Rod Assy. — Intermediate	184	14488	Corrector — Conv. Cl. Overhub-3.4 Shift
▲131	7A663	Bracket — O/D	156	7D028	Spring Intern. Band Servo Piston	185	6916	Solenoid Assy — Converter Clutch
132	7D441	Seal (Front Oil Pump)	157	E860343	Ring — Ret. 67 x 15 — O/D	186	6916	Solenoid Assy — 3.4 Shift
133	7D429	Seal (Intern. Brk. Drum) — 2 Req'd	158	E863170-S	Seal — Servo Cover to Case — O/D	187	7A191	Gasket — Oil Pan
134	7D014	Weather (Frt. Pump Input Thrust) Seal. Frt. — #1	159	7L493	Cover & Seal Assy. — O/D Band Servo	188	7190	Roller Overrun Clutch 2.3L, 2.9L & 3.0L
135	7L201	Support & Gear Assy (Frt. Pump)	160	7E221	Piston & Rod Assy — O/D	189	7D235	Roller Overrun Clutch 2.3L, 2.9L & 3.0L
136	7L323	Seal (Front Pump Support)	161	7D028	Spring — O/D Band Servo Piston	190	7D235	Roller Overrun Clutch 2.3L, 2.9L & 3.0L
137	7A136	Gasket — Oil Pump	162	7D100	Gasket — Cont. Vw. Bdy. Sep.	191	7A463	Tube-Lube Oil Inlet — Short
138	7B472	Plate (Oil Pump Adapter)	▲163	7A008	Plate — Viv. Bdy. Separating	192	7D235	Washer — Fwd. Ring Gear Thrust — #6
139	7975	Hsg. Assy — Converter	164	7D100	Gasket — Cont. Vw. Bdy. Separating	191A	7D0901	Washer — Fwd. Ring Gear Thrust
140	7A248	Seal Assy (Frt. Oil Pump)	165	7A100	Control Assy — Main	192	N804798-S100	Connector Assy-Oil Tube — 2 Req'd
141	7017	Input Shaft	166	E800153-S72	Screw M6 x 40 (Valve Body to Case) 19 Req'd	194	7A045	Integral Thrust Washer 2.3L, 2.9L and 3.0L Engines
142	7902	Converter Assembly	▲167	7D190	Rod — Rev. Band Servo Piston	195	7C489	Drum Assy (Rev. Brake) 4.0L
143	E804594-S	Screw M10 x 30 (Conv. Hsg. to Case) 8 Req'd	▲168	E830138-S	Rod — Rev. Servo Cushion Spring	196	7F205	Stud-O/D Brk. Drum Apply (4.0L)
144	E854104-S	O-Ring	169	7E207	Spring — Rev. Servo Cushion Spring	197	7B178	Output Shaft Sleeve (4.0L only)
145	E804372-S72	Boil — Fig. Htd. B.8 x M8 x 35.0 (Pump Supt. Assy to Conv. as Assy) 5 Req'd	170	7423	Seal — Rev. Brd. Servo Ret. Oil — Small	197	7C109	Overrun Clutch — Spring Type (4.0L only)
			171	7D031	Spring — Rev. Servo Piston			
			172	7D030	Piston & Rod Assy — Rev. Servo			
			▲173	E860167-S	Ring Retainer (Ret. Rod to Piston)			

## Transmission

NOTE: Bolt identification sizes for the following procedures indicate the head size, not the thread size.

### Disassembly

1. Remove torque converter.

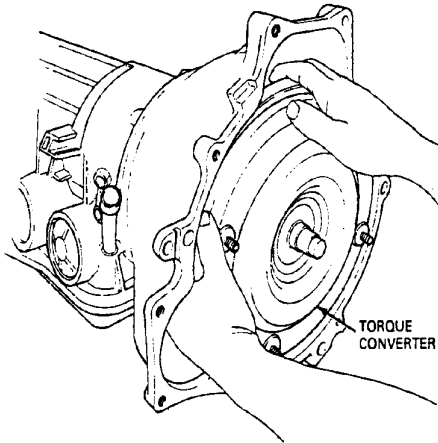

2. Remove input shaft.  
NOTE: The two splined ends are different.

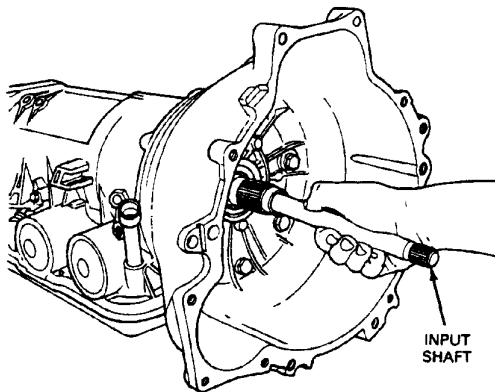

3. Remove eighteen 13mm bolts, then oil pan.

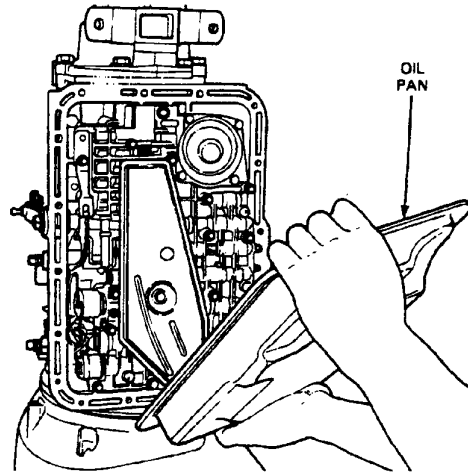

4. Remove 10mm bolt (M6 x 45mm long) then remove filter screen.
5. Remove detent spring.

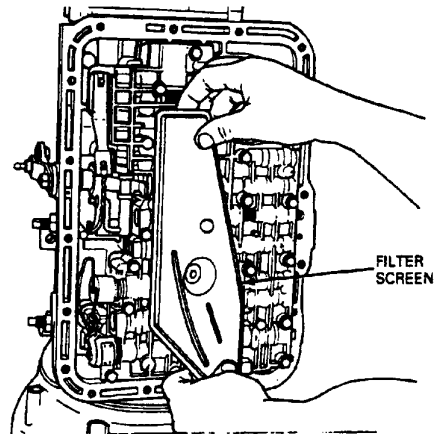

6. Disconnect 2 wires at converter clutch solenoid. Disconnect the 2 wires at the 3-4 shift solenoid.

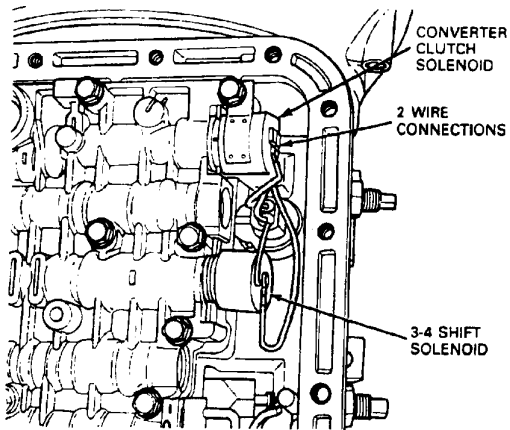

7. Remove twenty five-10mm bolts retaining valve body to case. While easing valve body out of the transmission, unlock and remove selector lever connecting link. Remove valve body and gasket.

NOTE: There are four different lengths of bolts—30mm, 35mm, 40mm and 45mm.

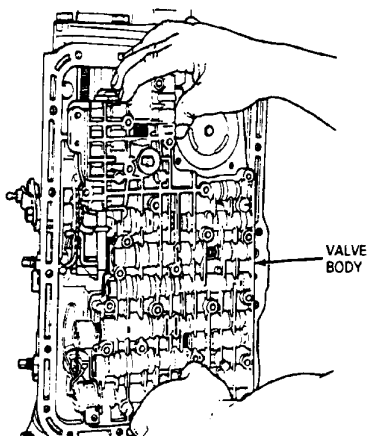

8. Remove 5mm allen-head retaining bolt holding center support.

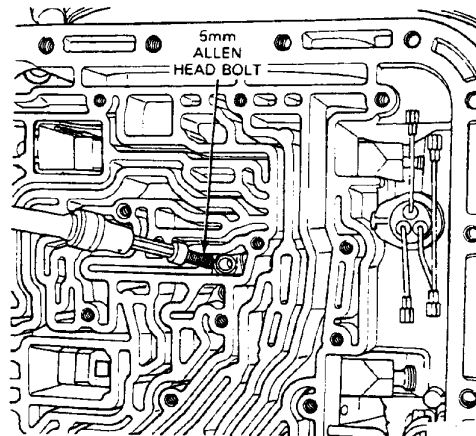

9. Remove six 17mm bolts and studs, then remove extension housing.

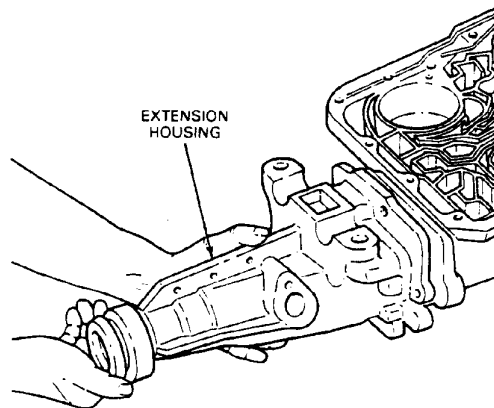

10. Remove the parking pawl and the return spring.

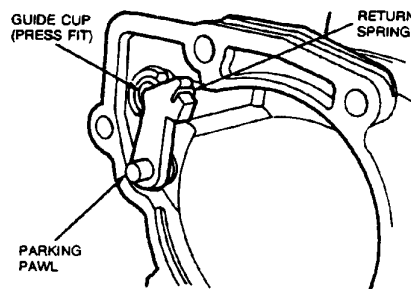

11. Remove two 10mm bolts, then remove governor.

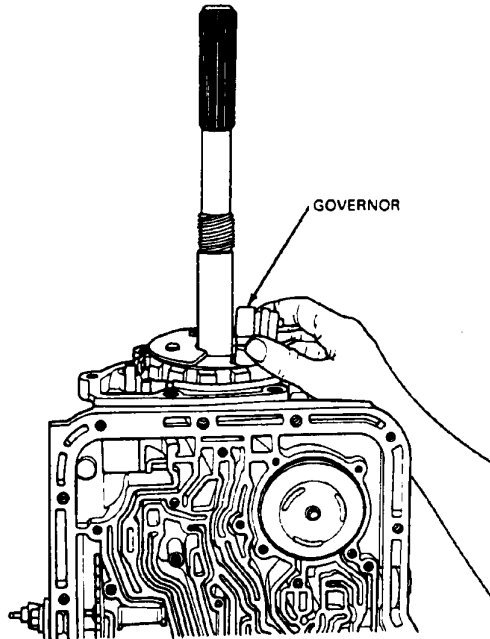

- 12. Mount transmission in Bench Mounted Holding Fixture T57L-500-B (or equivalent) as shown.
- 13. Two 10mm bolts, 50mm long will be required.

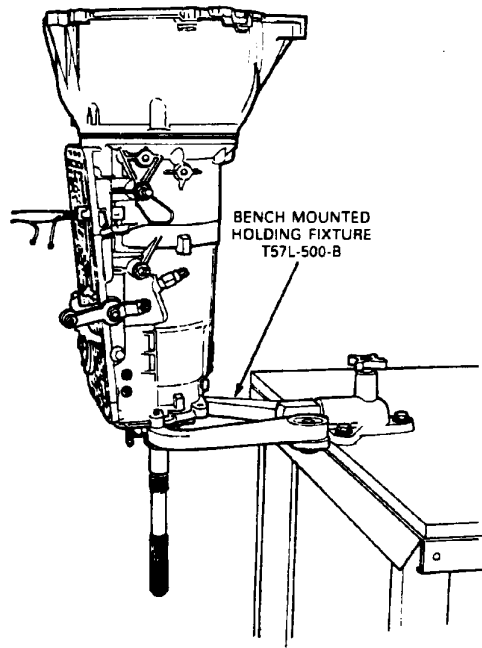

- 14. Remove eight 17mm bolts, then remove converter housing and pump as an assembly.
- 15. Rotate and lift so that clutches will stay in place. Remove the No. 1 thrust washer and the gasket.

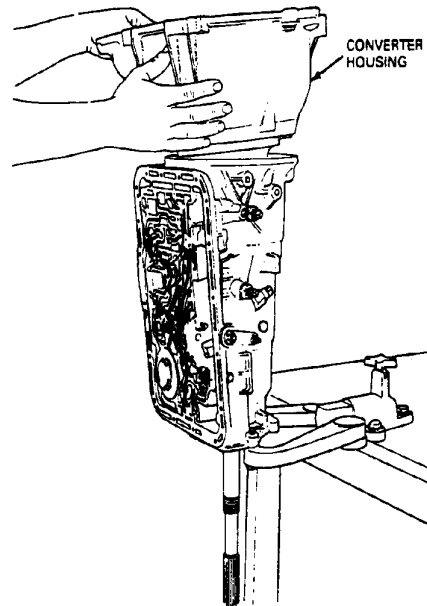

16. Remove hydraulic pump oil seal using Seal Remover T74P-77248-A, or equivalent, with a spanner.
17. Remove the hydraulic pump from the converter housing and remove the steel plate (behind oil seal) with the O-ring.

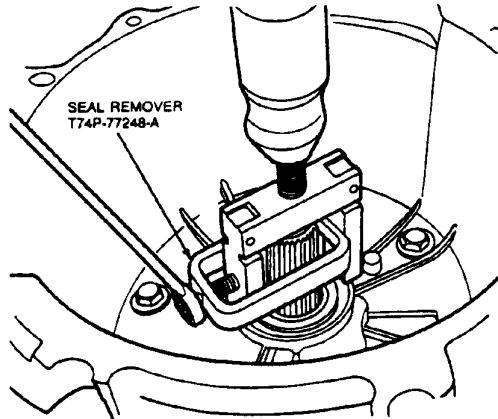

18. Loosen overdrive band lock nut and back off adjusting screw.
19. Lock nut will be discarded and a new nut will be used, as lock nut and seal are one piece.
20. Remove anchor and apply struts.
21. Lift out overdrive clutch assembly and band.  
NOTE: Identify band as "overdrive" and identify either "apply" or "anchor" end for reinstallation in order to distinguish it from the intermediate band. 4.0L applications use a double wrap design band.

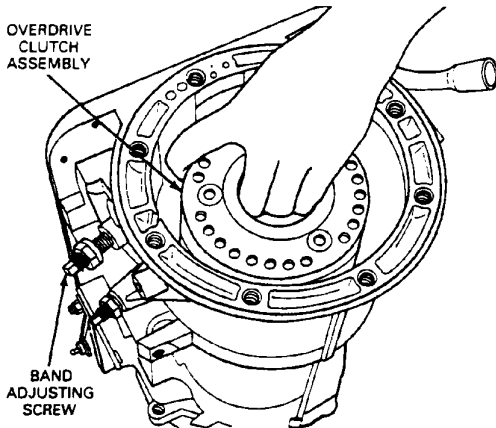

22. Lift out overdrive one-way clutch and planetary assembly.

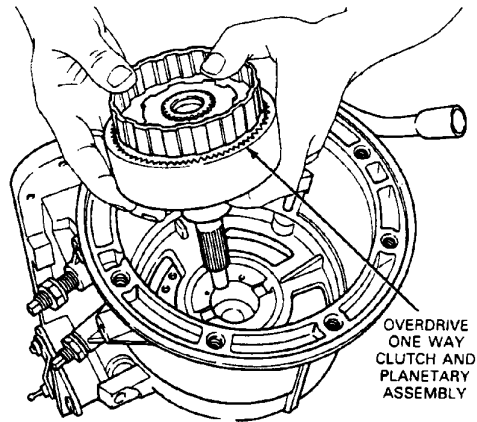

23. Remove center support retaining snap ring.

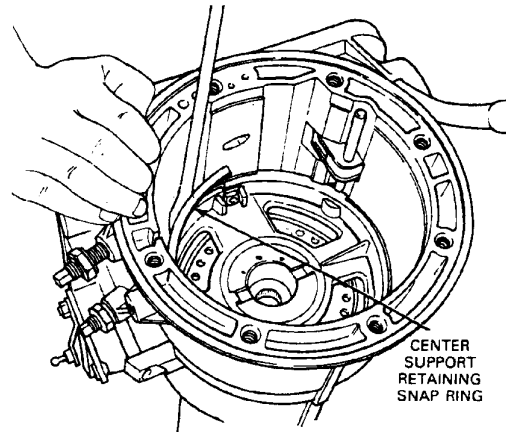

24. Remove overdrive apply lever and shaft.
25. Remove overdrive control bracket from valve body side of case.



NOTE: The overdrive apply lever does not have a boss on the shaft hole as compared to the intermediate apply lever. The overdrive apply lever shaft is longer as compared to the intermediate apply lever shaft.

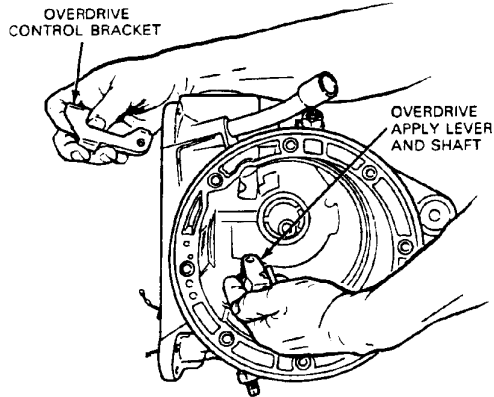

26. Remove thrust washer on top of center support.  
NOTE: Identify thrust washer for reassembly.

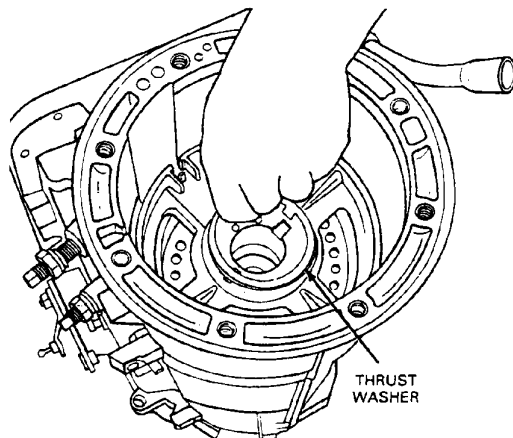

27. Remove center support being careful to pry upward evenly.

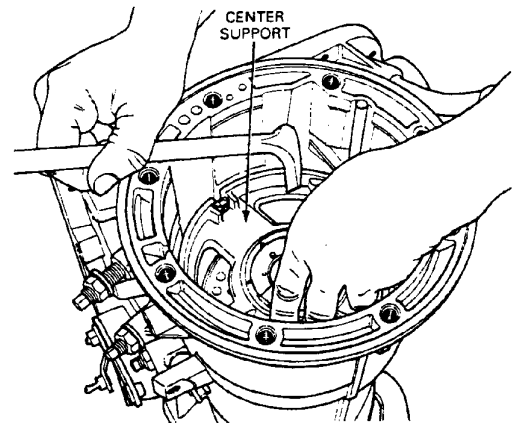

28. Remove thrust washer below center support.  
NOTE: Identify thrust washer for reassembly.

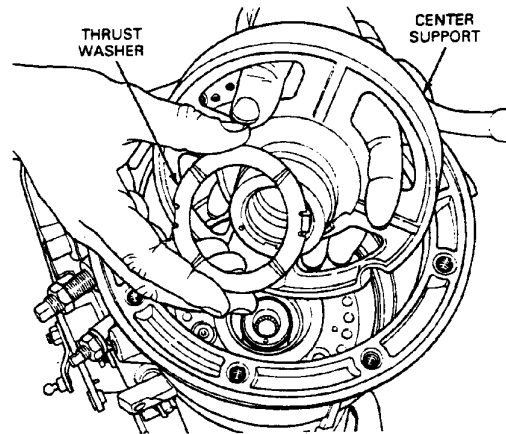

29. Loosen intermediate band lock nut and back off adjusting screw.  
30. Lock nut will be discarded.  
31. Turn transmission in holder, down 90 degrees.  
32. Remove anchor and apply struts.

33. Remove reverse / high and forward clutch assembly.

REVERSE/HIGH  
AND FORWARD  
CLUTCH ASSEMBLY

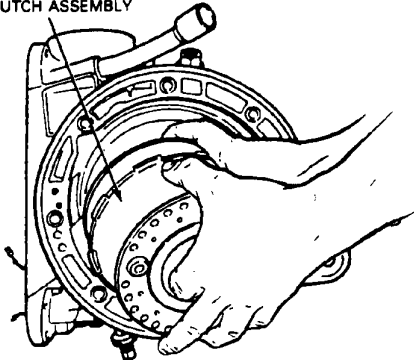

34. Remove intermediate band.

NOTE: Identify band as "Intermediate" and identify which end is "apply" or "anchor" side for reinstallation purposes.

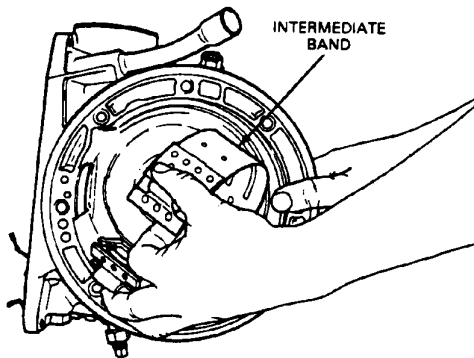

35. Remove forward planet assembly. Depending on application, some vehicles will have transmissions with aluminum planet carrier assemblies and some will have stamped steel planet carrier assemblies.

36. Note and identify No. 6 thrust washer, or thrust bearing.

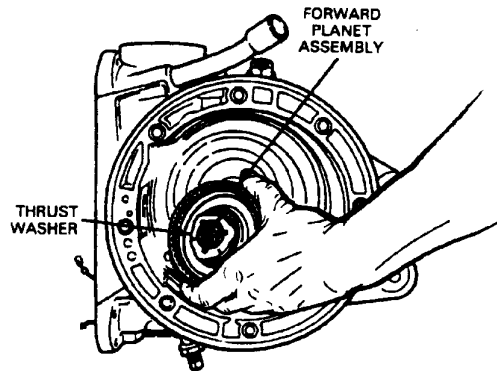

37. Remove sun gear shell.

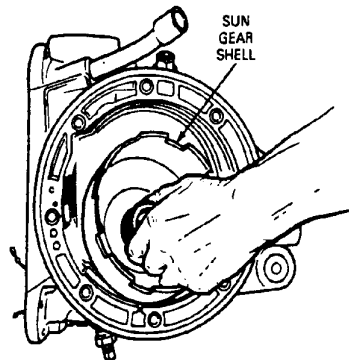

38. For all applications except 4.0L; remove large snap ring from reverse planet gear carrier.

NOTE: Transmissions used with 4.0L engines do not use a snap ring at this location.

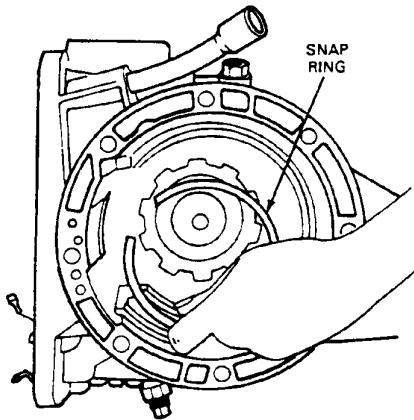

- 39. Remove reverse planet assembly.
- 40. Note and identify thrust washers on both sides. They are identical.

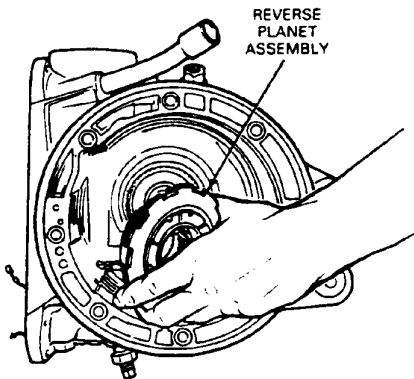

- a. With 4.0L applications; remove output shaft sleeve (lubricant guide).

OUTPUT  
SHAFT  
SLEEVE

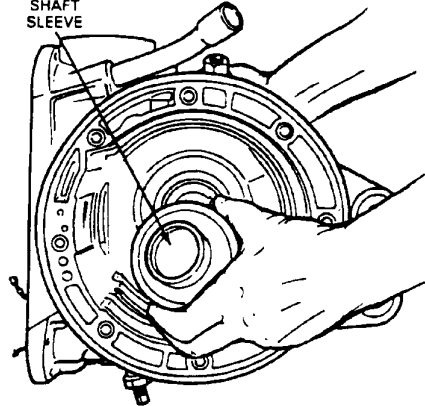

- 41. Remove small snap ring on output shaft.

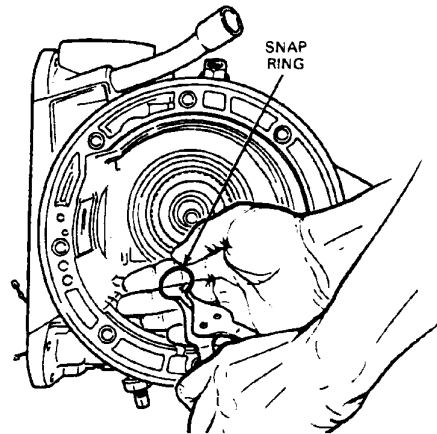

- 42. Remove output shaft ring gear.

OUTPUT  
SHAFT  
RING GEAR

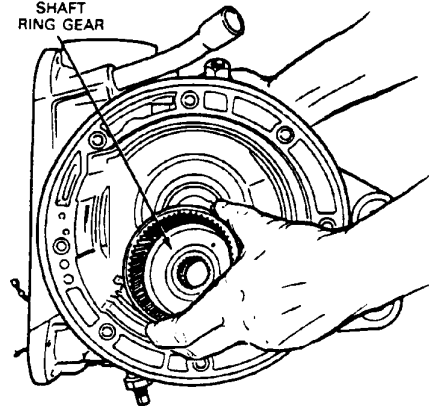

43. Remove low-reverse drum and one-way clutch assembly.

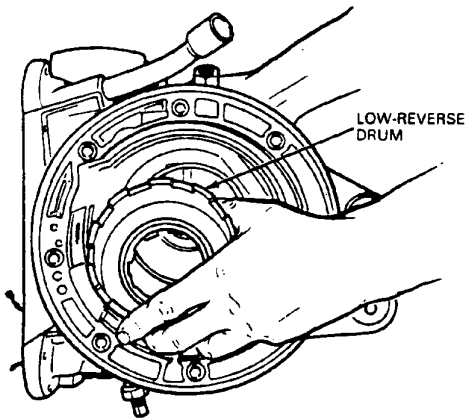

44. Remove low-reverse servo from valve body side of case.

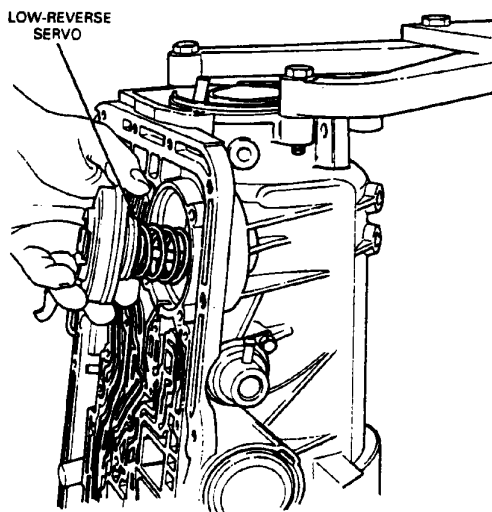

45. Remove low-reverse band.

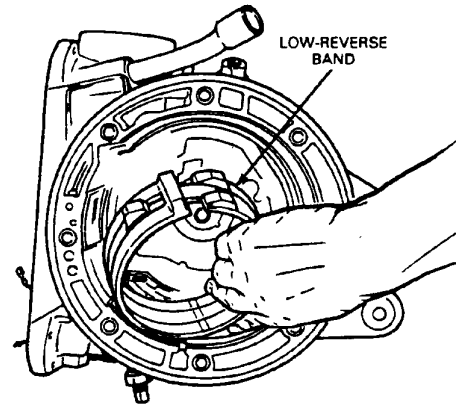

46. Remove thrust washer.

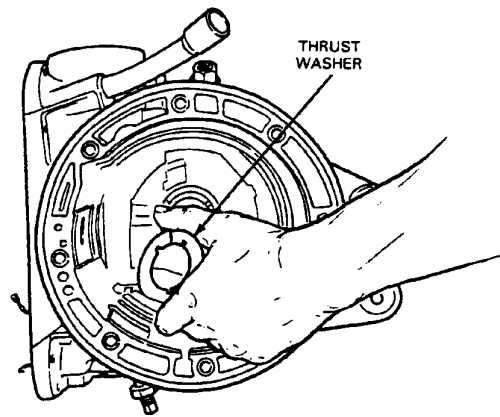

NOTE: Inner race of rear one-way clutch is not removable from case.

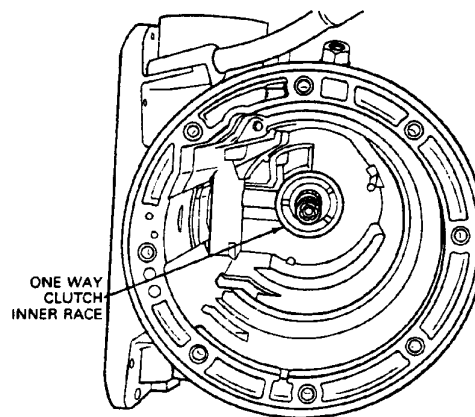

47. Remove intermediate apply lever and shaft.
  48. This apply lever has a boss on the shaft hole and the shaft is shorter than the overdrive shaft.
- NOTE: A control bracket is not used.

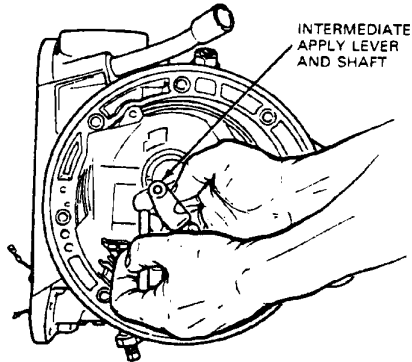

49. Turn transmission so that output shaft points upward.
  50. Remove output shaft by pulling upward.
- NOTE: If output shaft is to be replaced, 4.0L applications use an output shaft that does not have a lubricant hole.

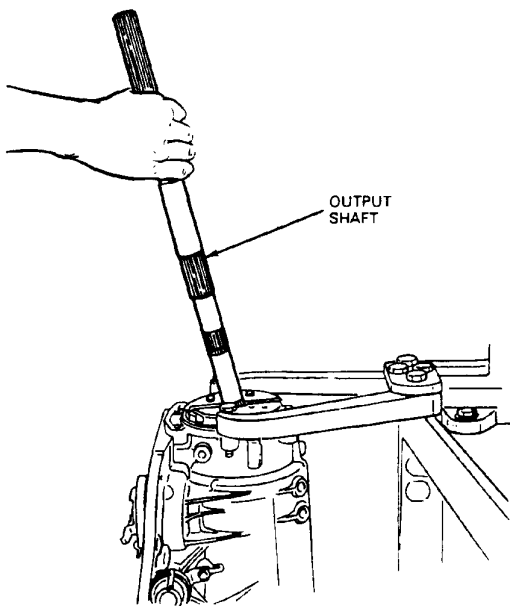

51. Remove park gear / collector body assembly from rear of case.

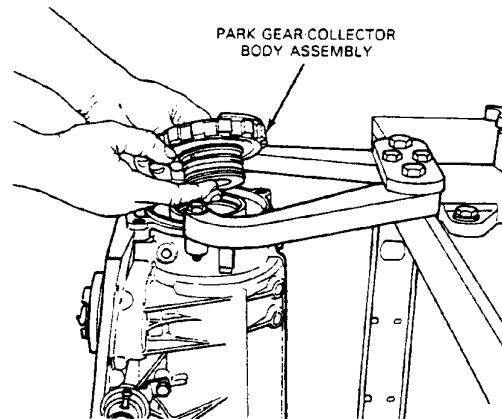

52. Remove thrust washer.

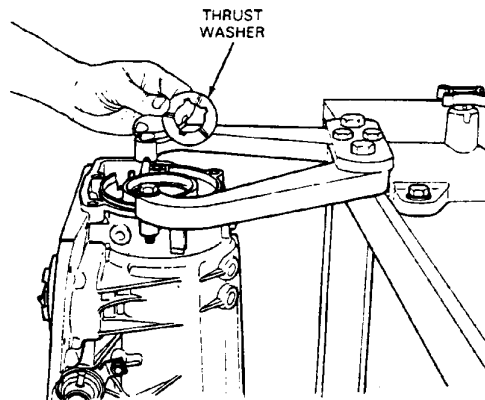

53. Remove one 10mm (M6 x 12mm long) bolt and retainer.
54. Remove vacuum diaphragm and throttle valve actuator rod.

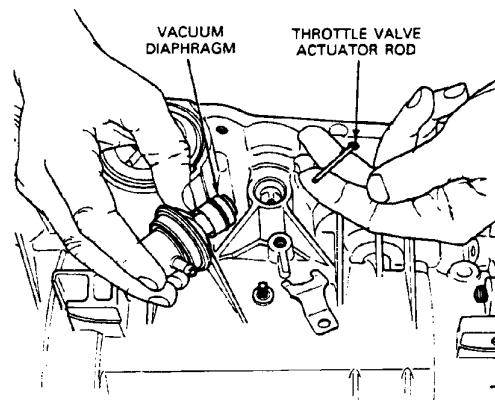

55. Verify that the throttle valve moves freely using flat needle nose pliers.
56. Remove throttle valve, using needlenose pliers.

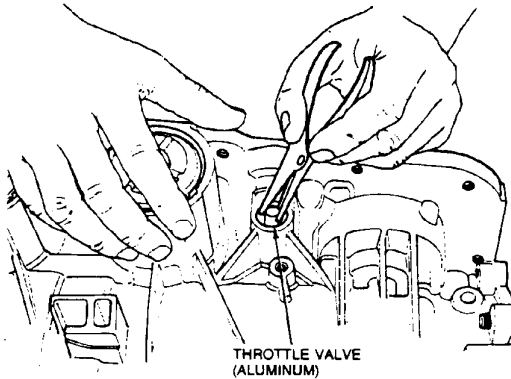

57. Remove intermediate servo cover snap ring.
58. Transmission case is notched out to permit easy snap ring removal.

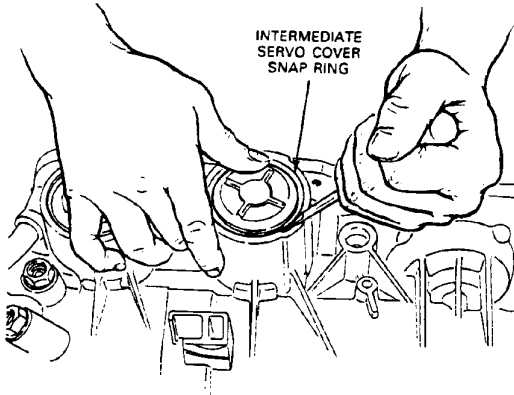

59. Remove intermediate servo cover, piston and spring.
  60. Remove overdrive servo cover snap ring.
  61. Remove overdrive servo cover, piston and spring.
- WARNING: COVERS CAN POP OFF DUE TO SPRING PRESSURE BEHIND PISTON.**
62. Covers usually can be removed by tapping lightly on cover or side of case.

63. Occasionally, covers must be removed using air pressure.

**CAUTION: Identify the overdrive cover and piston from the intermediate cover and piston. Keep separate or tag for proper installation. Installation in the incorrect bore could cause band concerns due to pressure differences.**

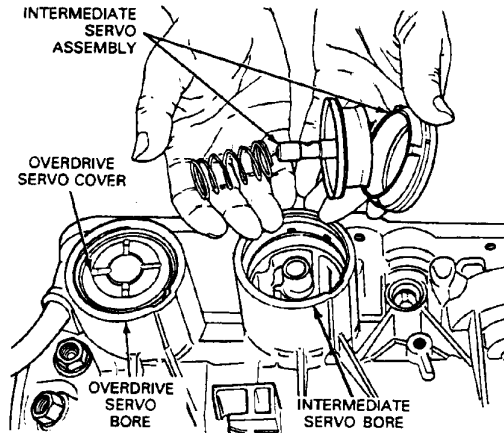

64. Air pressure may be used on release sides of pistons.

**CAUTION: Air pressure should not be greater than 137 kPa (20 psi).**

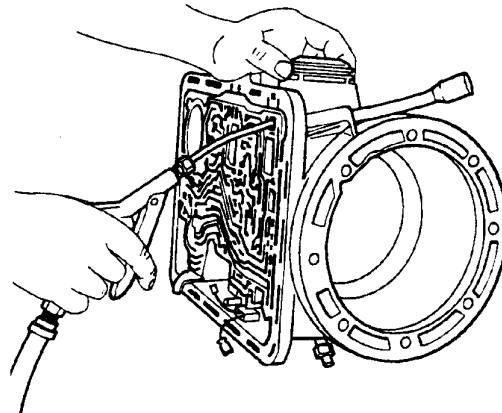

65. Remove neutral start switch using Neutral Start Switch Socket T74P-77247-A or equivalent.

**CAUTION:** Do not use an open-end wrench. Damage to neutral start switch can result.

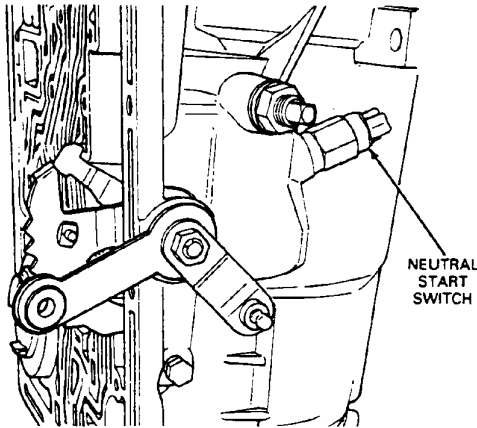

66. Remove 13mm kickdown lever nut, lever and O-ring seal.

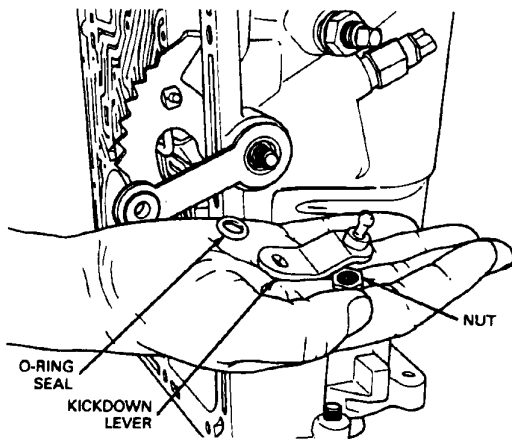

67. Remove linkage centering pin, taking care not to damage case flange.

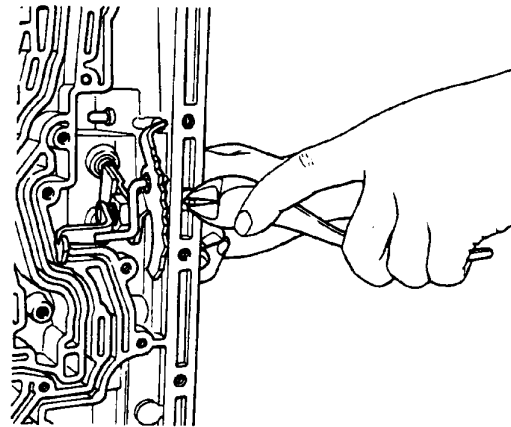

68. Remove 7/8 inch nut, manual lever, internal kickdown lever and park pawl rod and detent plate assembly.

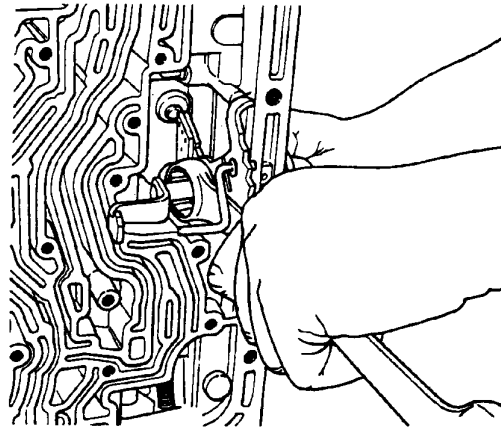

69. Remove lever shaft oil seal.

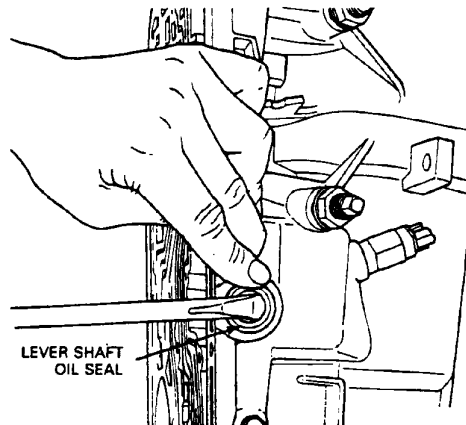

70. Remove case solenoid connector.
71. A tab on the outside of the case on backside of connector must be depressed while pulling with pliers. The tab is depressed with a small pair of locking pliers.
- NOTE: The connector need not be removed unless it is to be replaced, and / or if the case is to be immersed in a degreaser.

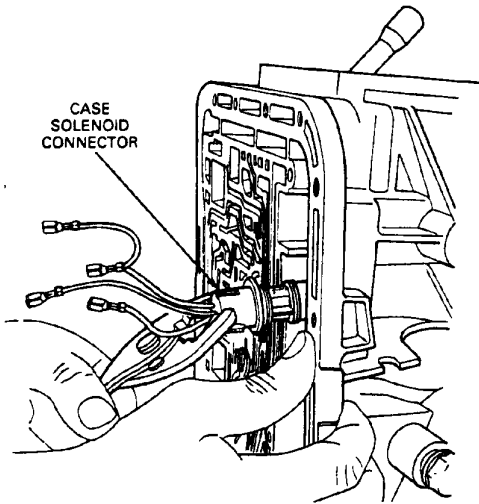

### Assembly

NOTE: Before beginning assembly of the transmission, the following high clutch seal sizing procedure must be performed.

1. Install new high clutch seals on the support hub. It is necessary to size these seals.

NOTE: The seal grooves have a "dovetail" contour with straight sidewalls on the pressure sealing sides.

NOTE: If this is not done, the seals can be cut or rolled over when entering the intermediate brake drum cavity.

Apply a liberal amount of petroleum jelly to the center support hub and seals.

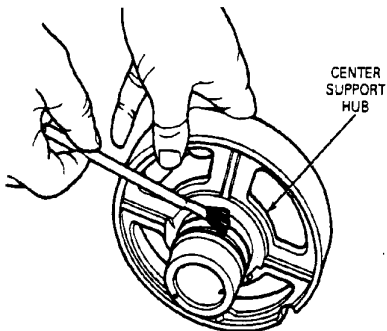

2. Use overdrive brake drum as sizing tool. Carefully rotate the center support while inserting.

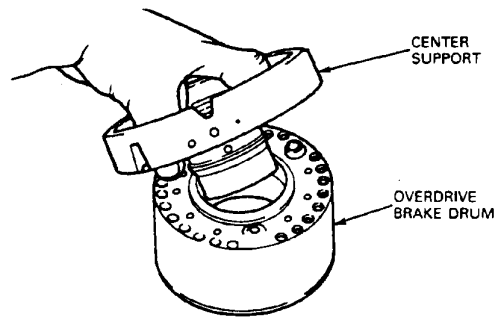

3. Observe the seals as they enter the cavity to see that they do not roll over or get cut.

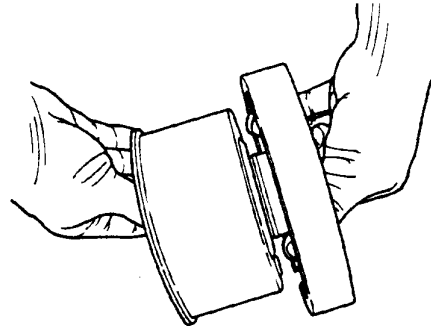

4. Be sure the center support is seated fully into the overdrive drum. Allow to stand for several minutes so that the seals seat in the grooves. Set aside until required for reassembly later in this section.

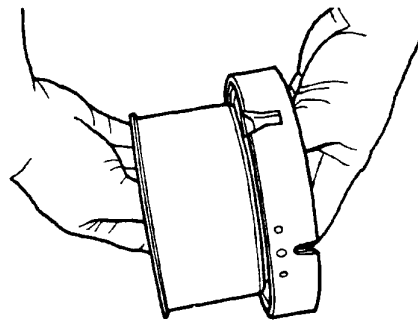



5. Place thrust washer No. 11 (7B368) into back of case.

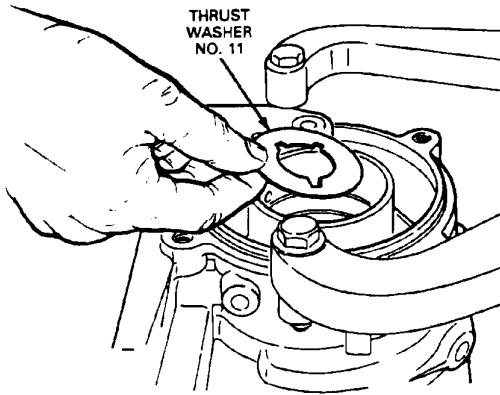

6. Install collector body in rear of case.

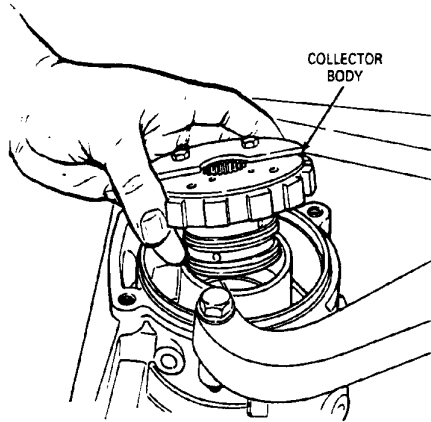

7. Install output shaft.
- NOTE: If a new output shaft is being installed, 4.0L applications use an output shaft that does not have a lubricant hole.

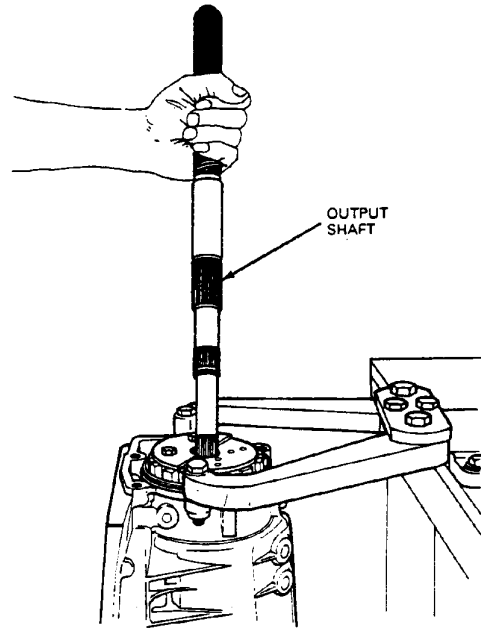

8. Install governor on collector body with two retaining bolts. Tighten to 9-14 N·m (84-120 lb-in).

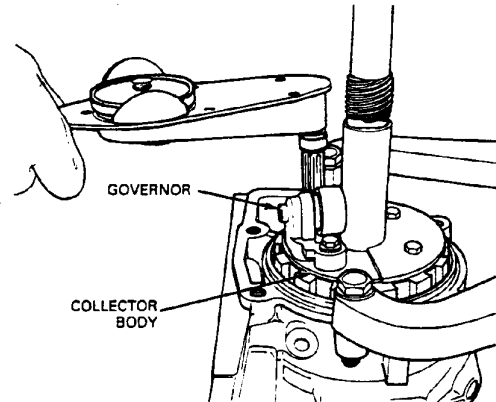

9. Place thrust washer No. 10 (7D422) into case from the front.

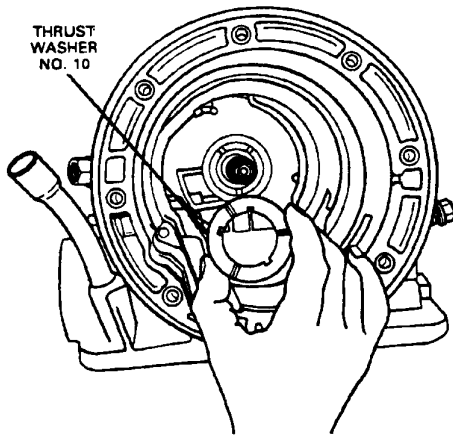

10. Install low-reverse drum using Overrunning Clutch Replacement Guide Tool T74P-77193-A or equivalent.

NOTE: With 4.0L applications, use a "sprag" type overrunning clutch and the replacement guide tool is not required.

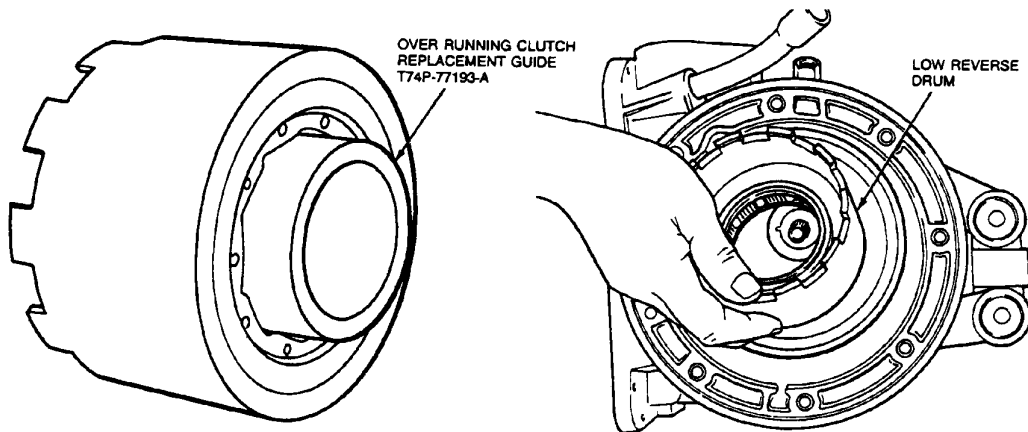

11. Install output shaft ring gear and snap ring onto output shaft.  
 NOTE: Always use a new snap ring for assembly.

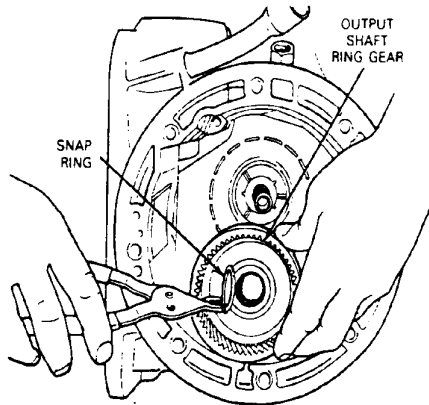

- a. With 4.0L applications; install the output shaft sleeve (lubricant guide).

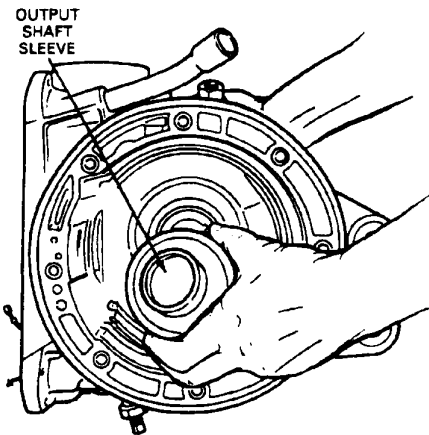

12. Install thrust washer No. 9 (7D423), reverse planet assembly and thrust washer No. 8 (7D423).

13. Use petroleum jelly to hold thrust washers in position on planet assembly.

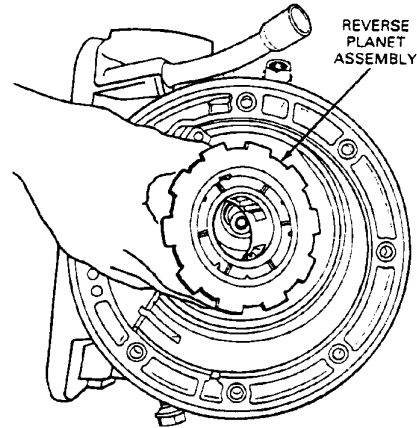

14. Install snap ring in drum to hold planet assembly in place.

NOTE: 4.0L applications do not have a snap ring at this location.

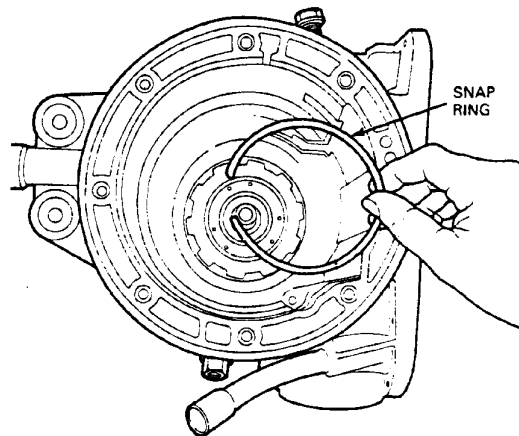

15. Install low-reverse band.

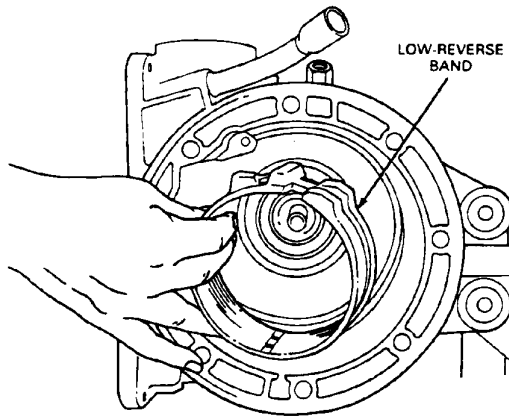

16. Replace servo piston or O-ring if necessary.

17. Install low-reverse servo piston to hold band in position.

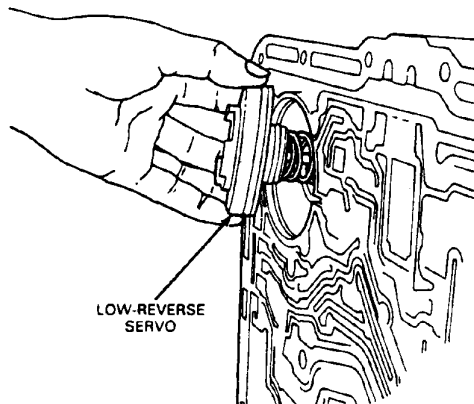

18. Replace piston or O-ring if necessary.

19. Install intermediate servo spring, piston, cover and snap ring. Refer to the Specifications portion of this section for proper means of identifying overdrive from intermediate servo covers and components.

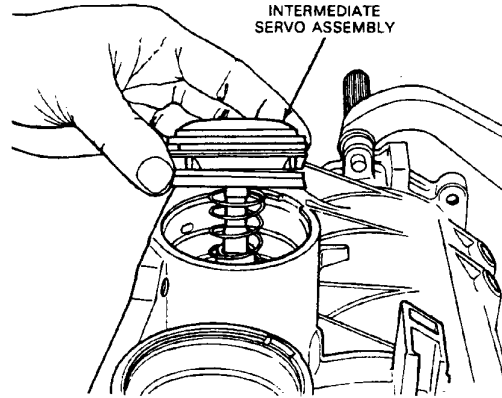

20. Replace piston or O-ring if necessary.

21. Install overdrive servo spring, piston, cover and snap ring. Ensure correct cover is installed, as identified by a tag during disassembly.

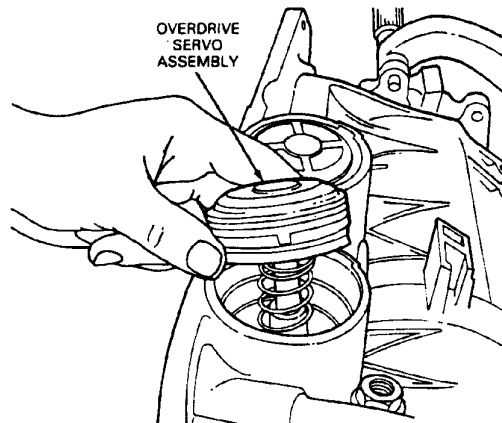

22. Locate and identify intermediate servo apply lever and shaft.

23. The intermediate servo apply lever is the lever that has a boss on the shaft hole and the shaft is shorter than the overdrive shaft.

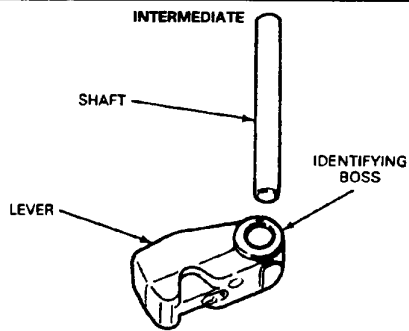
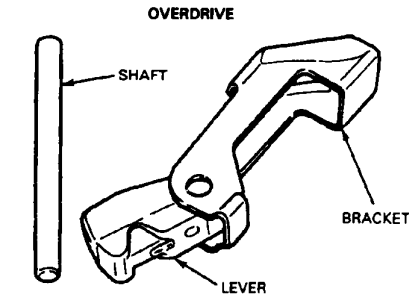

24. Install intermediate servo apply lever and shaft into case.

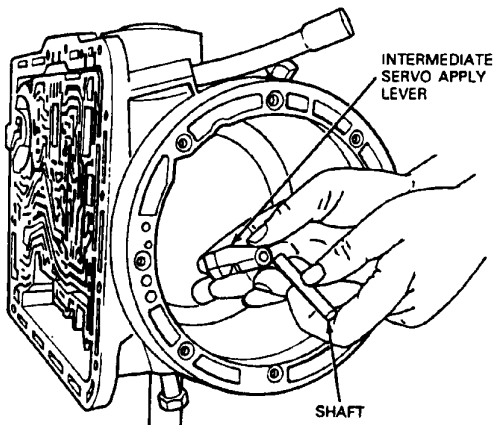

25. Install the complete forward clutch and reverse and high clutch assemblies.

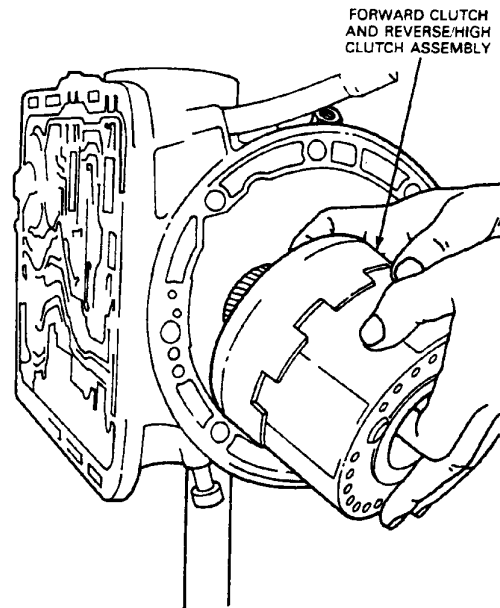

26. Turn transmission so that the output shaft points downward.

27. Install intermediate band and apply strut.

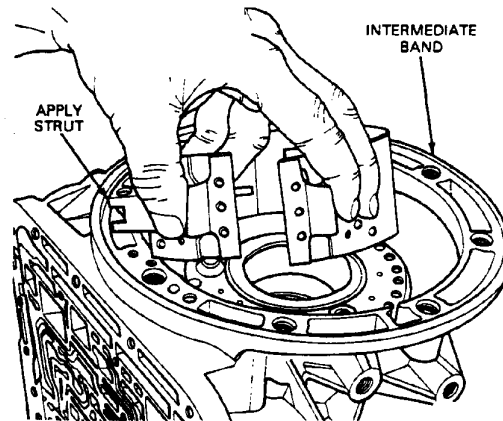

28. Install the intermediate band anchor strut and input shaft (temporarily) as an alignment guide, then go to the transmission rear end play check.

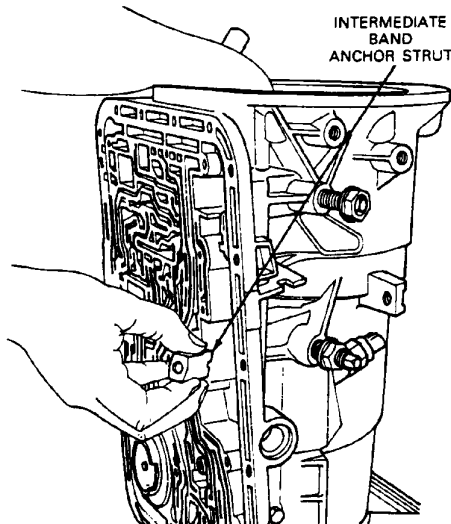

29. The transmission rear end play check determines:

- a. the amount of space existing between the thrust washer surfaces of the overdrive center support and the intermediate brake drum.
- b. the thickness of the No. 4 thrust washer that is required to obtain an end play of 0.30-0.54mm (0.012-0.022 inch).

To perform the end play check, fabricate a depth gauge fixture from a spare overdrive center support. A 3mm (1/8 inch) hole must be drilled through the thrust washer surface of the center support. This allows Depth Micrometer D80P-4201-A or equivalent access to the area between the thrust surfaces of the support and the intermediate brake drum. Remove the rubber seals from the spare center support to allow easy insertion into the intermediate brake drum.

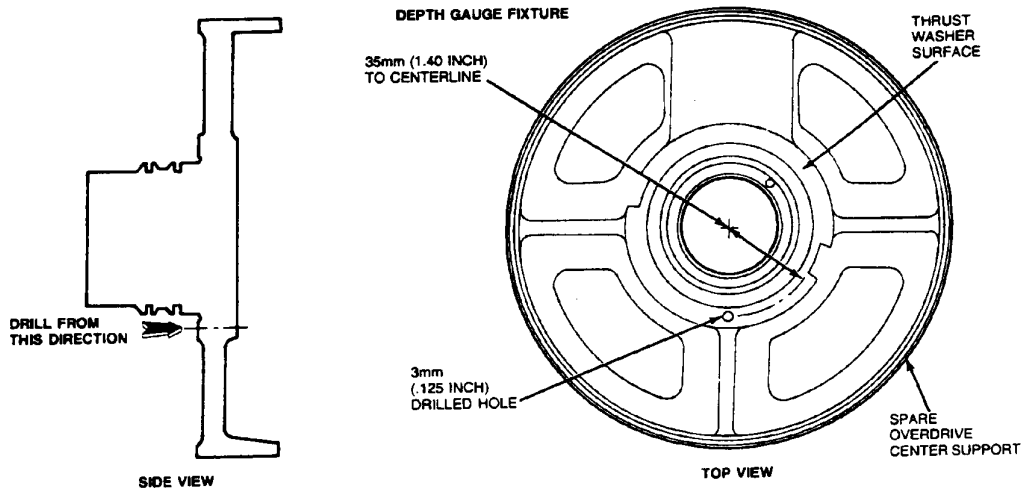

30. Place Depth Micrometer D80P-4201-A or equivalent over drilled hole in the fabricated depth gauge fixture. Extend micrometer probe until it is flush with the thrust washer surface of the fixture. Record the micrometer reading. This is Reading A.

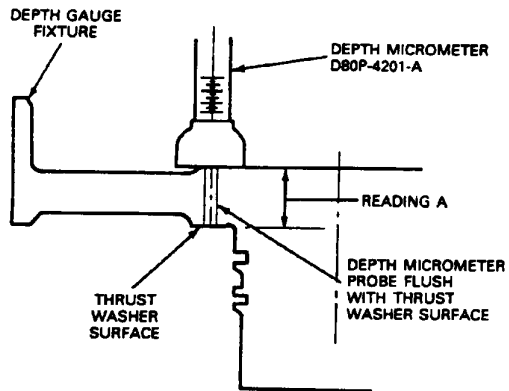

31. Install the depth gauge and input shaft fixture into the intermediate brake drum and make sure it is fully seated in the transmission case. Gently "wiggle" input shaft to allow center support fixture to slide into intermediate brake drum using its own weight. The fixture axially locates the drum in its proper position.

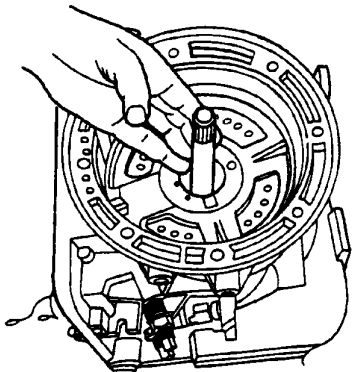

32. Place depth micrometer over the drilled hole in the fixture.

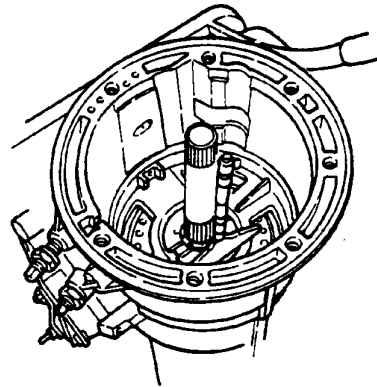

33. Continue extending the micrometer probe until it contacts the thrust washer surface of the intermediate brake drum. This is Reading B.
34. Subtract Reading A from Reading B. The difference between these readings is Dimension A. This is the space between the thrust surfaces.

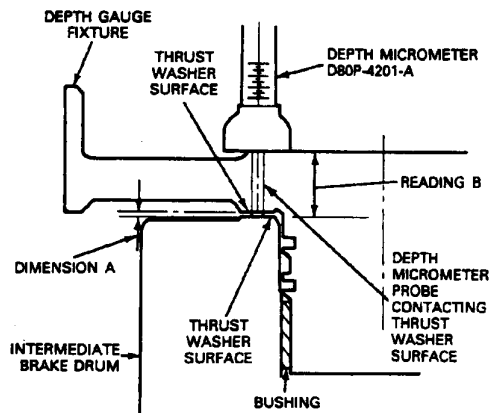

35. Remove and rotate the fixture 180 degrees. Repeat steps 30 through 34.
36. Average the two Dimension A readings to obtain the final Dimension A reading.
37. Locate the final Dimension A reading in the following chart and select the proper thrust washer required to obtain the specified end play of 0.30-0.54mm (0.012-0.022 inch). If Dimension A is outside the specified limits, this indicates improper assembly, missing parts or parts out of specification. This requires a rebuild of the unit.

### TRANSMISSION END PLAY SELECTIVE THRUST WASHER CHART

Dimension A		Thrust Washer Identification	Thrust Washer Thickness		Thrust Washer Part Number
mm	Inch		mm	Inch	
1.46-1.65	0.057-0.064	A	1.2	0.047	89DT-7D014-HA
1.66-1.85	0.065-0.073	1	1.4	0.055	89DT-7D014-AA
1.86-1.95	0.074-0.077	2	1.6	0.063	89DT-7D014-BA
1.96-2.05	0.078-0.081	3	1.7	0.067	89DT-7D014-CA
2.06-2.15	0.082-0.085	4	1.8	0.071	89DT-7D014-DA
2.16-2.25	0.086-0.089	5	1.9	0.075	89DT-7D014-EA
2.26-2.35	0.090-0.093	6	2.0	0.079	89DT-7D014-FA
2.36-2.45	0.094-0.100	7	2.1	0.083	89DT-7D014-GA
2.46-2.65	0.097-0.104	B	2.2	0.087	89DT-7D014-MA
2.66-2.85	0.105-0.112	C	2.4	0.094	89DT-7D014-JA
2.86-3.05	0.113-0.119	D	2.6	0.102	89DT-7D014-KA
3.06-3.15	0.120-0.096	E	2.8	0.110	89DT-7D014-LA

38. Remove depth gauge and input shaft fixture from overdrive drum. This procedure (sizing of seals) was begun in steps 1 through 4 of this section (Transmission Assembly). Position the correct No. 4 (7D014) selective washer on rear of center support using petroleum jelly.
39. Insert the input shaft (short splines down) through the center support and into the splines in the forward clutch cylinder.

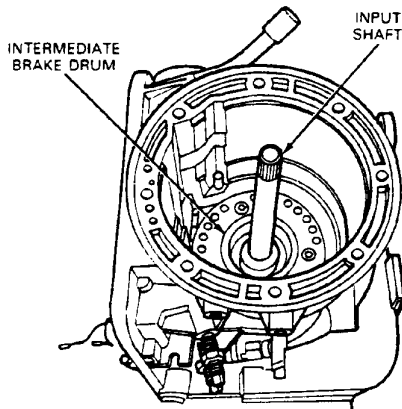

40. Carefully place the center support into the case, but do not start it into the intermediate brake drum. Be sure it is square with the case and the 5mm allen-head bolt retainer nut is oriented with the bolt hole in the case.

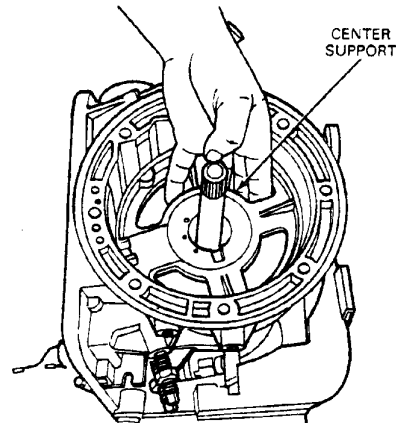

41. DO NOT apply any pressure to the center support. Gently "wiggle" the input shaft allowing the center support to slide into the intermediate brake drum using its own weight. Perform this operation until the support is fully seated. Remove the input shaft.



42. Position No. 3 (7L326) thrust washer on top of center support.

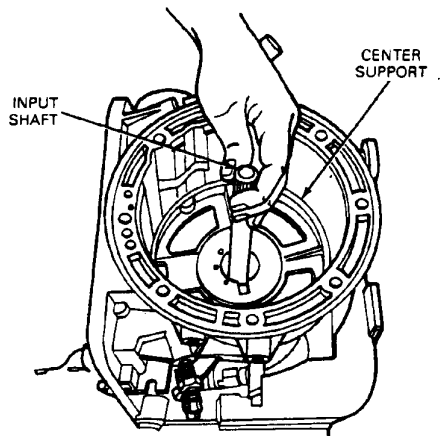

43. Install large snap ring to retain center support in position with taper snap ring toward the front of the transmission.

NOTE: The ends of the snap ring should be positioned in the wide shallow cavity located in the five o'clock position.

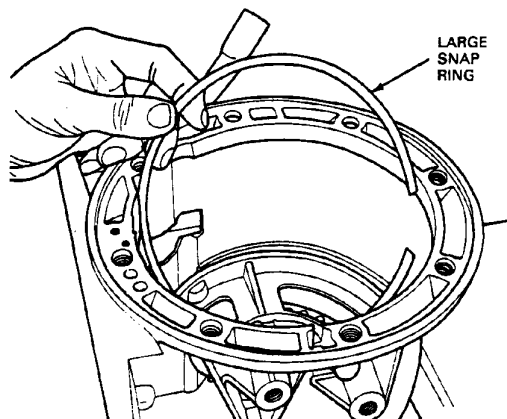

NOTE: Two types of center support retaining snap rings are used. One is identified by holes located in the inner and outer diameter; the other type of snap ring has no holes. They should be positioned as shown.

"HOLE TYPE" SNAP RING

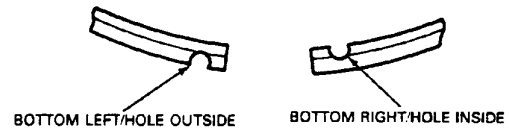

"NON-HOLE TYPE" SNAP RING

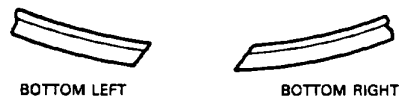

44. Install 5mm allen-head bolt that retains center support to case.

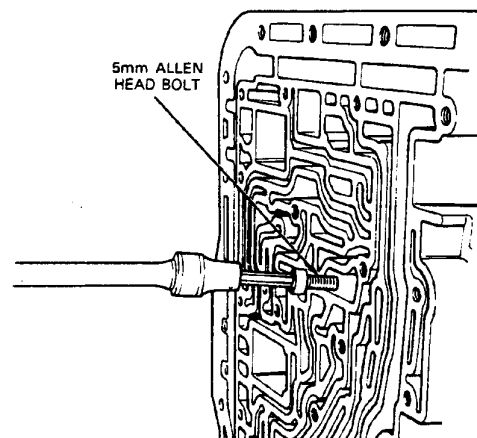

45. Install sun gear and overdrive clutch adapter into overdrive planet assembly and one-way clutch. The part number on the adapter should face the sun gear.

46. Take care to center needle bearing race inside of planetary. Be sure it stays centered, and positioned with the extruded lip in the upward position (toward sun gear).

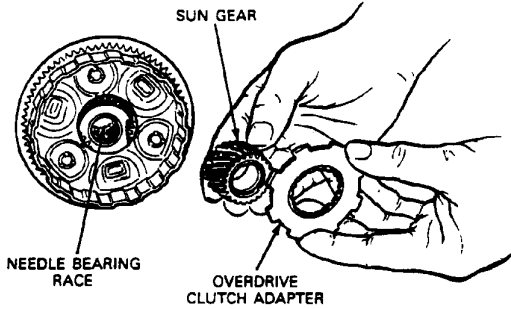

47. Assemble the overdrive planet and one-way clutch assembly.
- a. The one-way clutch assembly **MUST** be installed into the centershaft in such a way that the flanges of the inner and outer cages are toward the overdrive planet assembly which is toward the front of the transmission.

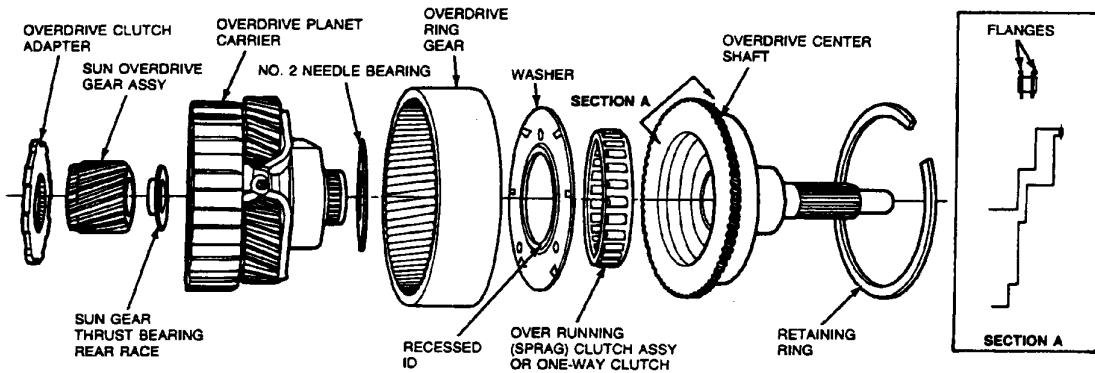

- b. The overdrive clutch washer, that is positioned between the overdrive planet carrier and centershaft must be installed in such a way that the "recessed ID" faces forward (not against sprag clutch).

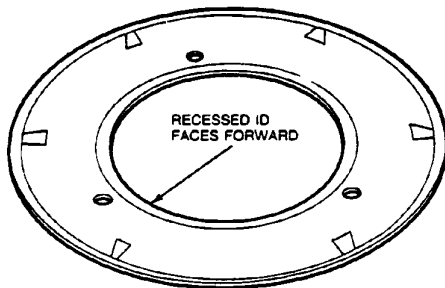

- c. To perform the proper assembly buildup check, hold the planet assembly—then the centershaft should turn clockwise.

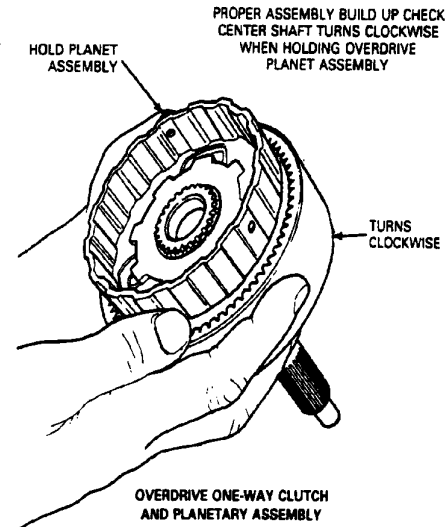

48. Install overdrive planet assembly and one-way clutch into case.

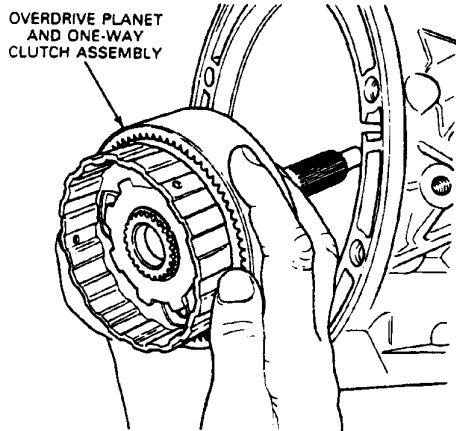

49. Install overdrive drum assembly.

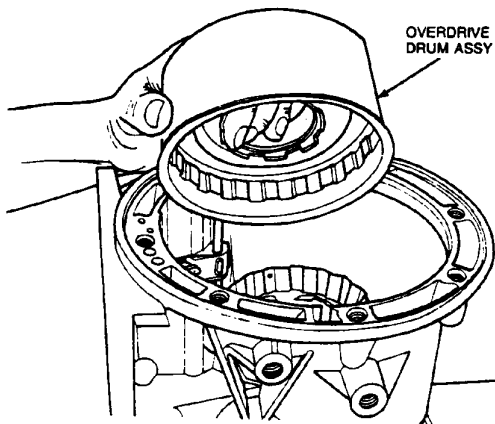

50. Install overdrive bracket, apply lever, and shaft.

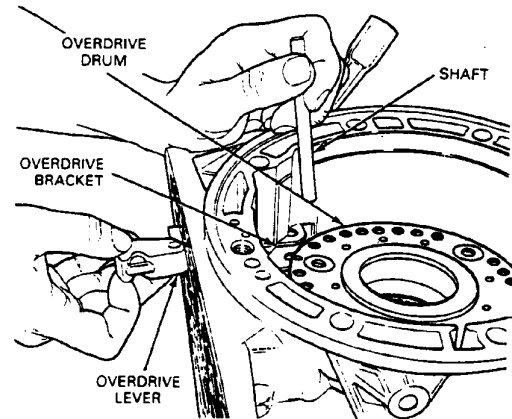

51. Install overdrive band and apply strut.

NOTE: Ensure correct band is installed as identified by a tag during disassembly.

NOTE: Band and strut for 2.3L, 2.9L and 3.0L applications shown. 4.0L applications use a double wrap design band.

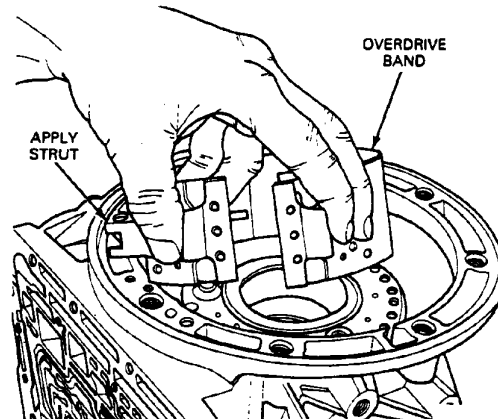

52. Install anchor strut.

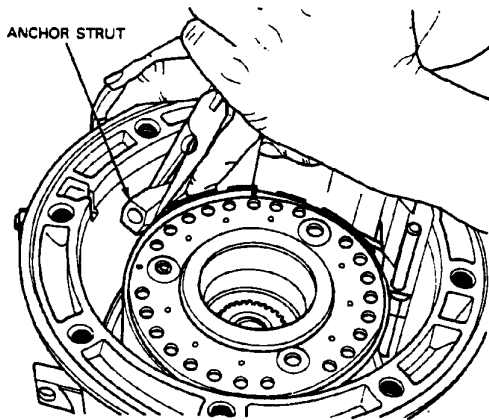

- 53. Verify that needle bearing race in overdrive planetary is centered and overdrive clutch is fully seated.
- 54. Place No. 1 (7D014) selective washer on top of overdrive clutch drum and temporarily install pump assembly into case. Be sure that it is fully seated in the case.
- 55. The pump body must be below the level of the case gasket in the case.

NOTE: Check for damaged or missing front pump support seal. Replace if necessary.

NOTE: Rough casting portion of the crescent. This is not a flaw and the pump should NOT be replaced.

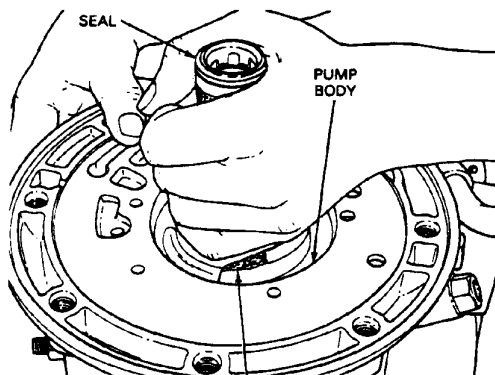

NOTE: ROUGH CASTING PORTION OF THE CRESCENT. THIS IS NOT A FLAW AND THE PUMP SHOULD NOT BE REPLACED.

- 56. Mount Dial Indicator D78P-4201-G or equivalent on the pump with plunger resting on the transmission housing. Set dial indicator to zero.

- 57. Swing indicator around so plunger contacts the pump. Check dial reading. This reading is the amount of end play. Note reading for later use.
- 58. Move dial indicator block to opposite side of the pump (180 degrees). Repeat steps 56 and 57.
- 59. Find average of two readings. This average reading of end play should be from 0.18mm to 0.64mm (0.007 to 0.025 inch). If reading exceeds the limits, change No. 1 selective washer.
- 60. The available selective washers are:

TRANSMISSION END PLAY SELECTIVE THRUST WASHER CHART

Thrust Washer Thickness		Thrust Washer Identification	Thrust Washer Part Number
mm	Inch		
1.2	0.047	A	89DT-7D014-HA
1.4	0.055	1	89DT-7D014-AA
1.6	0.063	2	89DT-7D014-BA
1.7	0.067	3	89DT-7D014-CA
1.8	0.071	4	89DT-7D014-DA
1.9	0.075	5	89DT-7D014-EA
2.0	0.079	6	89DT-7D014-FA
2.1	0.083	7	89DT-7D014-GA
2.2	0.087	B	89DT-7D014-MA
2.4	0.094	C	89DT-7D014-JA
2.6	0.102	D	89DT-7D014-KA
2.8	0.110	E	89DT-7D014-LA

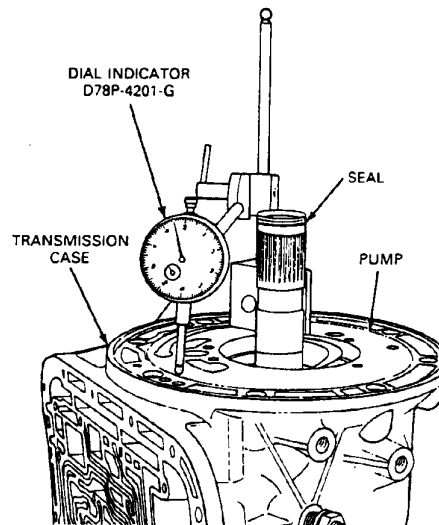

61. Install a new hydraulic pump oil seal using Front Pump Alignment Set T74P-77 103-X and Front Pump Seal Replacer T87L-77248-AH or equivalent. Stake the seal in place with tool T87L-77248-BH in 2 places between the existing stakes.

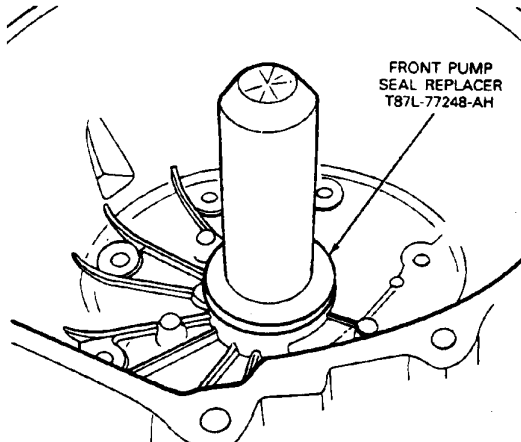

62. Properly position separator plate on converter housing.

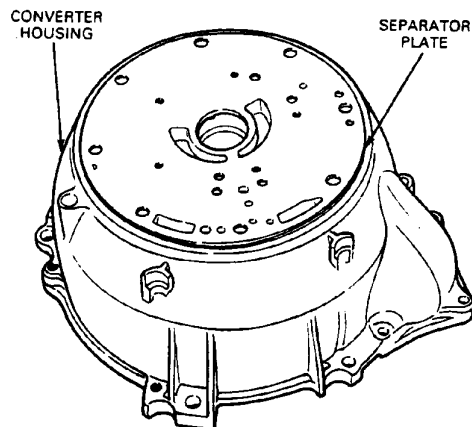

63. Properly position two pump gears into pump housing.  
64. The inside edge of the small gear has a chamfer on one side. This chamfer must be positioned toward the front of the transmission.

65. The larger gear has a dimple on one side which must be positioned toward the rear of the transmission.

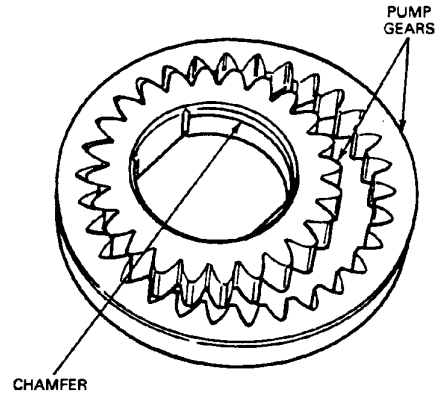

66. Position pump assembly onto separator plate and converter housing.

67. Install bolts finger-tight.

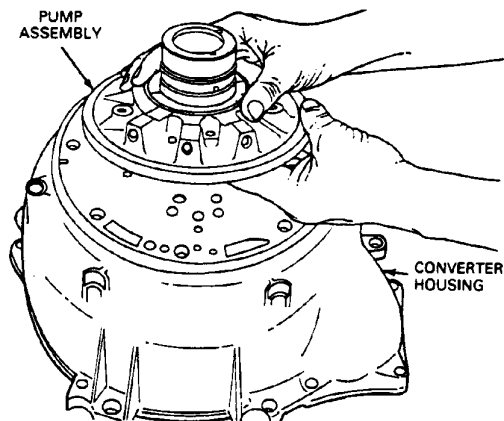

68. Align pump in converter housing using Front Pump Alignment Set T74P-77 103-X or equivalent. This tool must be used in order to prevent seal leakage, gear noise, pump breakage or bushing failure.

69. To use tool, select the arbor with the smallest ID that will fit completely over the pump shaft. Assemble the common handle to the selected arbor and slide the tool down over the shaft until it bottoms against the pump. The outside diameter of the tool arbor will then automatically center the pump in the converter housing.

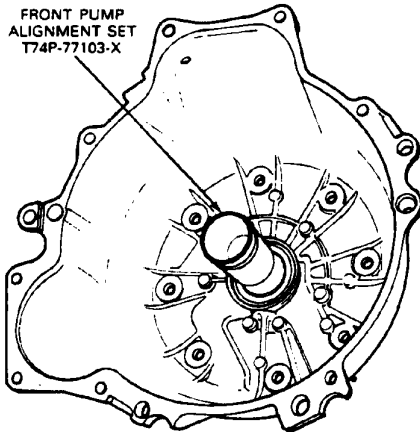

70. With alignment tool installed, tighten five new 6mm hex allen-head pump bolts (E804375-S72M) to 23-27 N-m (17-20 ft-lb).

**CAUTION: Be sure to install new bolts (E804375-S72M).**

71. Remove alignment tool.  
72. Insert the input shaft into the pump and install the converter into the pump gears. Rotate the converter to check for free movement, then remove the converter and input shaft.

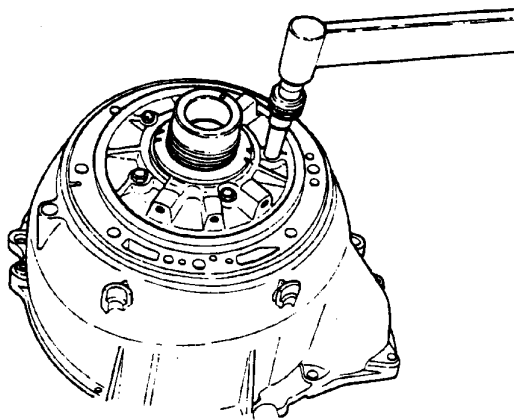

73. Coat converter housing gasket with petroleum jelly and position on housing.

74. Install seal on converter housing.

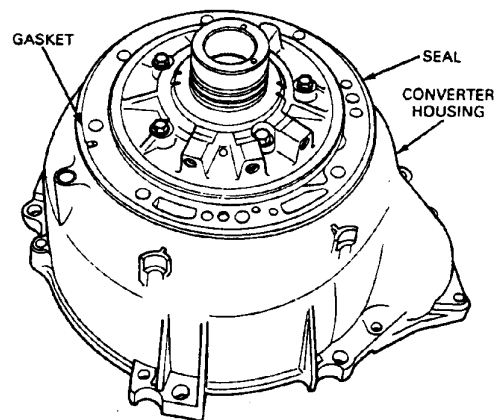

75. Using petroleum jelly, position No. 1 selective washer on rear of pump.  
76. Align converter housing and pump to the transmission.  
77. Install eight 17mm bolts, with new "O" rings, and tighten to 37-52 N-m (27-38 ft-lb).

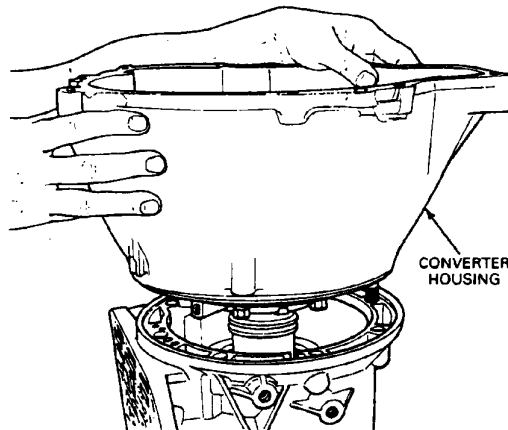

78. Using Band Adjustment Torque Wrench T71P-77370-A or equivalent, adjust overdrive band.  
79. Install a new lock nut on adjusting screw. Tighten adjusting screw until the tool handle clicks. This is 14 N-m (10 ft-lb).  
80. Back off adjusting screw exactly two turns (2.3L, 2.9L and 3.0L engine applications).  
a. For 4.0L engine applications back off adjusting screw exactly three and a half turns.

81. Hold adjusting screw from turning. Tighten the lock nut to 48-61 N-m (35-45 ft-lb).

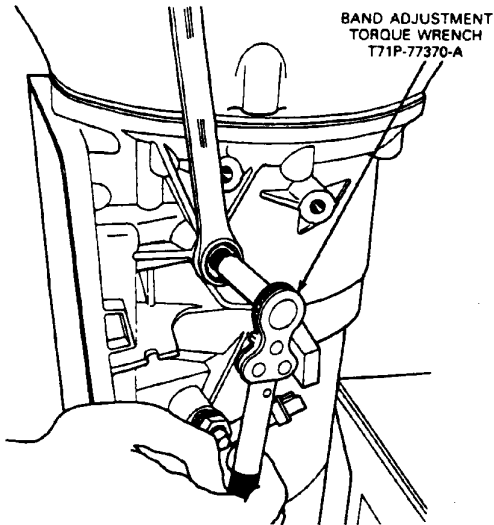

82. Following the previous method, adjust the intermediate band backing off the adjusting screw two turns before tightening the lock nut.

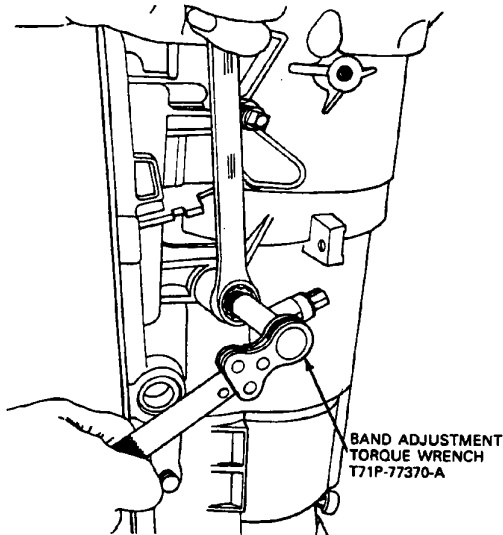

83. Install shift lever oil seal using Shift Lever Seal Replacer T74P-77498-A or equivalent.

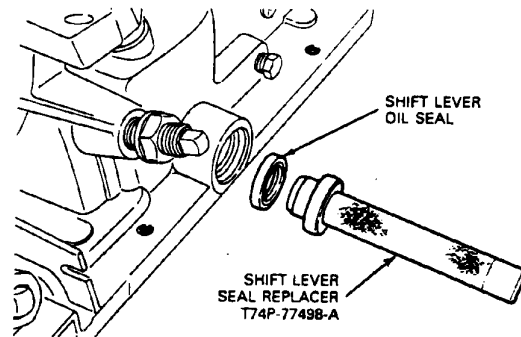

84. Install internal shift linkage, including external manual control lever, and centering pin. Tighten 7/8 inch nut to 41-54 N-m (30-40 ft-lb).

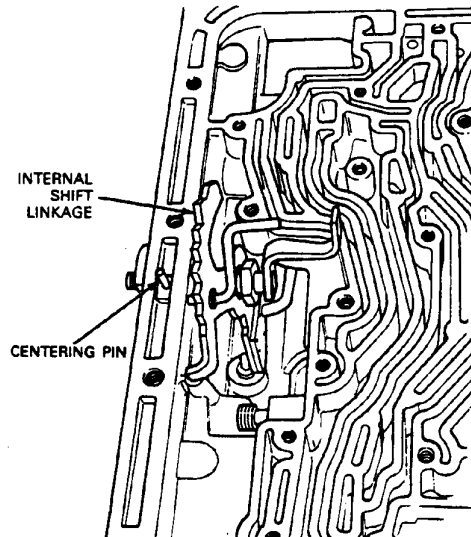

85. Install O-ring, kickdown lever and 13mm nut. Tighten to 10-14 N-m (7-10 ft-lb).

86. Install neutral start switch using Neutral Start Switch Socket T74P-77247-A "Thin Wall" socket or equivalent. Tighten to 9.5-13.6 N-m (84-120 in-lb).

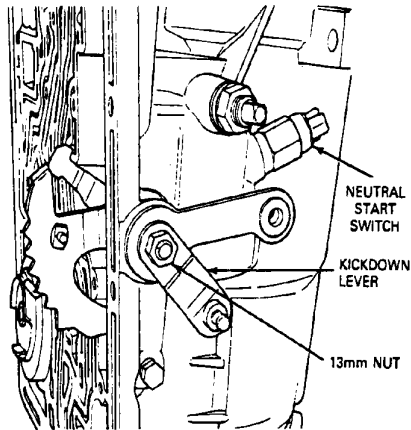

87. Install converter clutch solenoid connector.

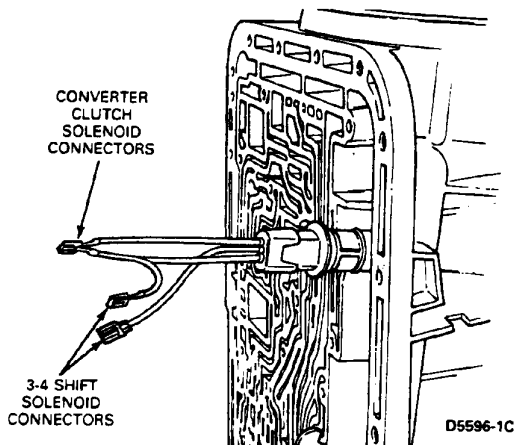

88. Install throttle valve, rod, vacuum diaphragm, retaining clamp and bolt.  
 89. Be sure the throttle valve moves freely in its bore. Use a pencil magnet to check movement if throttle valve is steel. If throttle valve is aluminum, use the end of a rubber object to check movement.

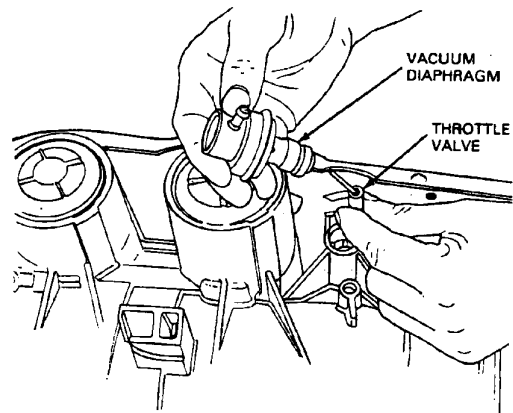

90. Align valve body to separator plate and gasket using tapered punches.  
 91. Install two 10mm bolts. Tighten to 9.5-12.1 N-m (84-107 in-lb).  
 92. Petroleum jelly must be used to keep gasket in proper location on the separator plate during assembly.

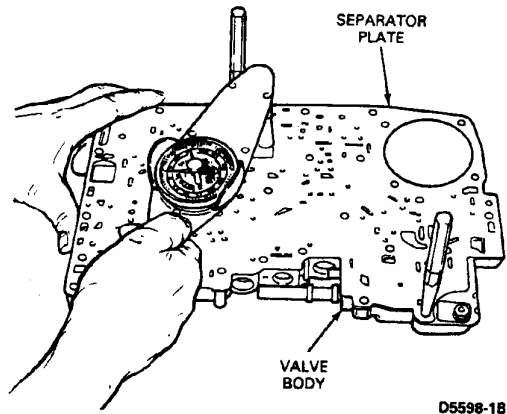

93. Remove transmission from holding fixture and place on bench bottom up.  
 94. Attach and lock the selector lever connecting rod (Z-Link) to the manual valve. Ease control body into the case.

**CAUTION: Use care not to bend selector lever connecting rod (Z-Link).**

Insert correct length bolts, finger-tight, in holes A and B to position control body to case.

95. Insert all remaining bolts (correct length) except the filter screen bolt. Tighten to specification.



96. Remove bolt from hole A and install the detent spring to bolt. Assemble and tighten A and B locations to specification. Install converter clutch solenoid wires.

97. For body bolt locations and sizes, refer to the following illustration.  
98. Follow tightening sequence from center of valve body to outer edges.

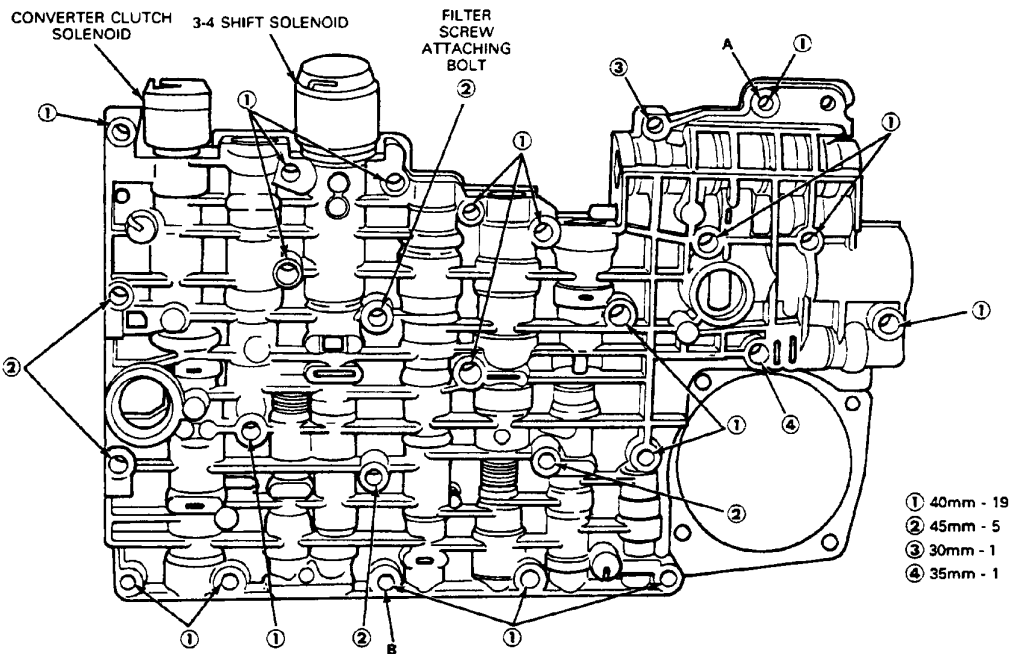
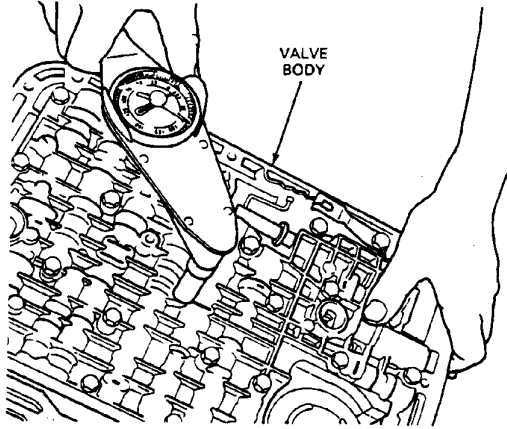

99. Install the reverse servo piston assembly into servo bore along with a reverse servo check spring D4ZZ-70031-A or equivalent.  
100. Install a new servo cover gasket and tool T74P-77190-A or equivalent and tighten with three attaching bolts.

101. Tighten servo tool adjusting screw to 4 N·m (35 in-lb).  
102. Install Dial Indicator with Bracketry TOOL-4201-C on transmission case and position indicator on piston pad. Set dial indicator to zero.

103. Back out the servo tool adjusting screw until piston bottoms out on the tool. Record the distance the servo piston traveled.

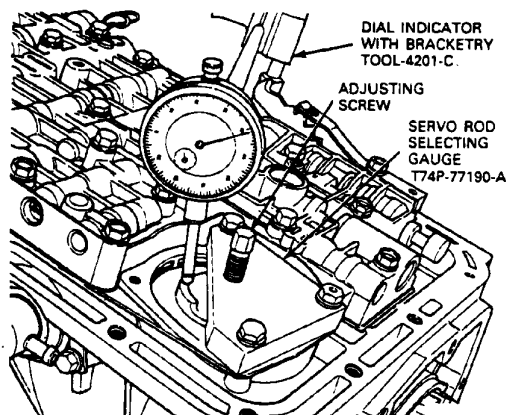

104. If piston travel is between 3 and 5.6mm (.120 and .220 inch), it is within specification.

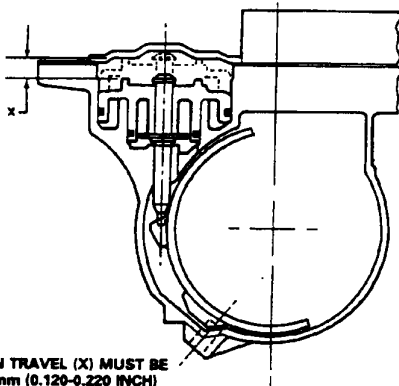

105. If piston travel is greater than 5.6mm (.220 inch), use the next longer piston and rod.  
106. If piston travel is less than 3mm (.120 inch), use the next shorter piston and rod.

Length — mm	Length — inches	I.D.
54/53 mm	2.112/2.085	1 Groove
51/50 mm	2.014/1.986	No Groove
49/48 mm	1.915/1.888	2 Grooves

107. Using the above procedure, check the piston travel with the new selected piston and rod (if required) to make sure that the piston travel is between 3 and 5.6mm (.120 to .220 inch).

108. Remove the servo adjusting tool and the reverse servo piston checking spring.  
109. Install the servo piston assembly, accumulator spring, gasket and cover.  
110. Install four 10mm servo retaining bolts and tighten to 10-13 N-m (7-10 ft-lb).  
111. Install new O-rings on the screen and lubricate with petroleum jelly.  
112. Install filter screen and one 10mm bolt. Tighten to 8-11 N-m (71-97 in-lb).

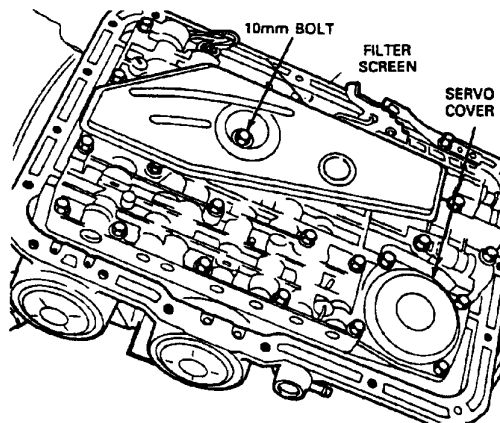

113. Remove any trace of old gasket on case and oil pan.  
114. Position oil pan gasket on case and install oil pan.  
115. Install 18-13mm oil pan retaining bolts. Tighten to 11-13 N-m (8-10 ft-lb).

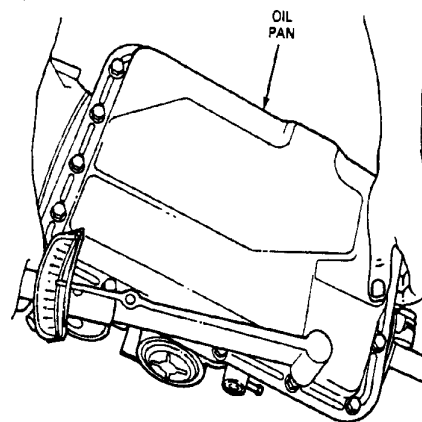

116. Remove any trace of old gasket on end of case and extension housing.

117. Install parking pawl and its return spring in the extension housing and preload.

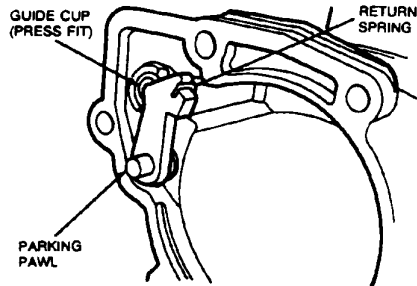

118. Using a new gasket, install the extension housing. Be sure to correctly seat the operating parking rod in the extension guide cup.
119. Install six extension housing retaining fasteners. Tighten to 37-52 N·m (27-38 ft·lb).

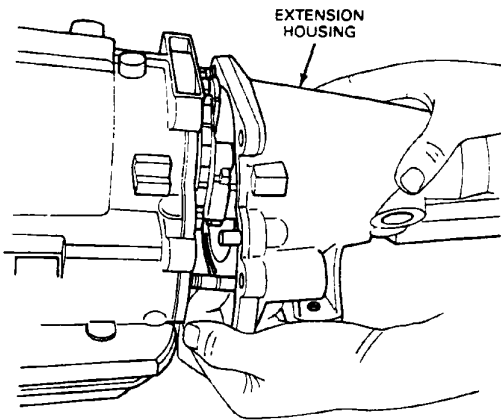

120. Remove extension housing seal using Extension Housing Seal Remover T71P-7657-A or equivalent.
121. Remove extension housing bushing using Extension Housing Bushing Remover T77L-7697-E or equivalent.
122. Install extension housing bushing using Extension Housing Bushing Replacer T77L-7697-F or equivalent.

123. Install extension housing seal using Extension Housing Seal Replacer T74P-77052-A or equivalent.

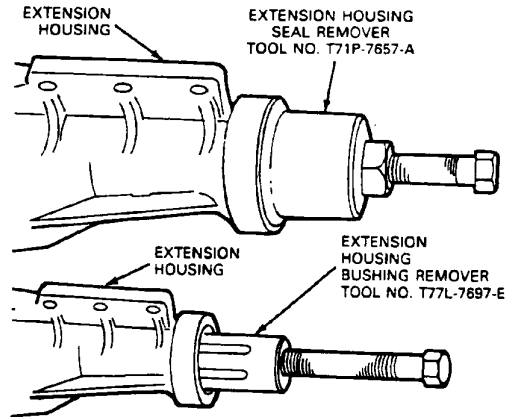

## Sub-assemblies

### Valve Body

#### Disassembly

1. Remove three Torx® head screws retaining separator plate and gasket to valve body.

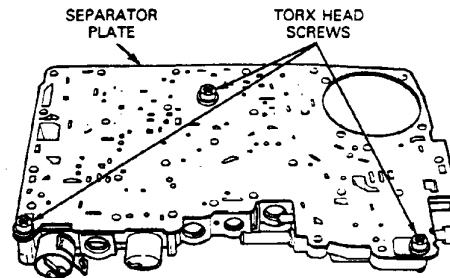

2. With separator plate and gasket removed, note location of:
  - Converter pressure relief valve and spring
  - TV pressure relief valve and spring
  - Three shuttle balls and one check ball
  - Accumulator check valve (two)

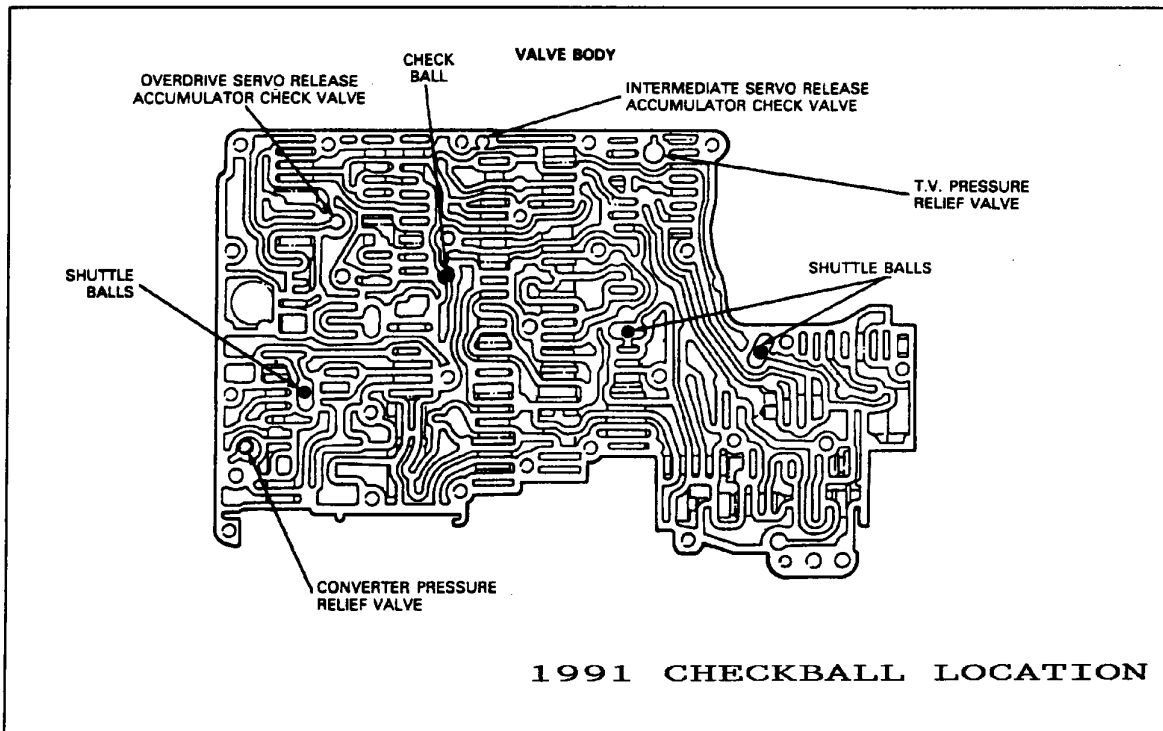

- Filter that is retained by the separator plate at converter clutch solenoid connector

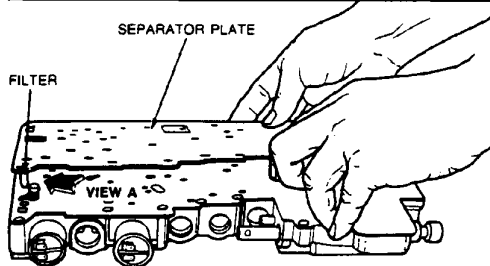
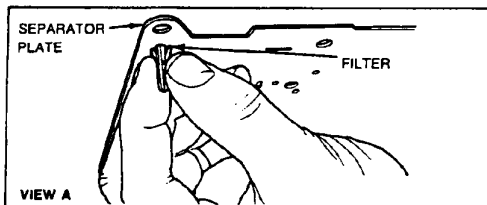

### Valve Body Valve Identification

The following procedural steps detail the removal and installation of the individual valves. Each valve body bore has been assigned a reference number on the assembled view. The illustrations have been assigned a corresponding reference number. Each set of illustrations contains the views necessary to remove and install the components contained in a particular valve body bore.



**EARLY 1985 - 1987  
HYDRAULIC 3-4 SHIFT CHECKBALL LOCATION**

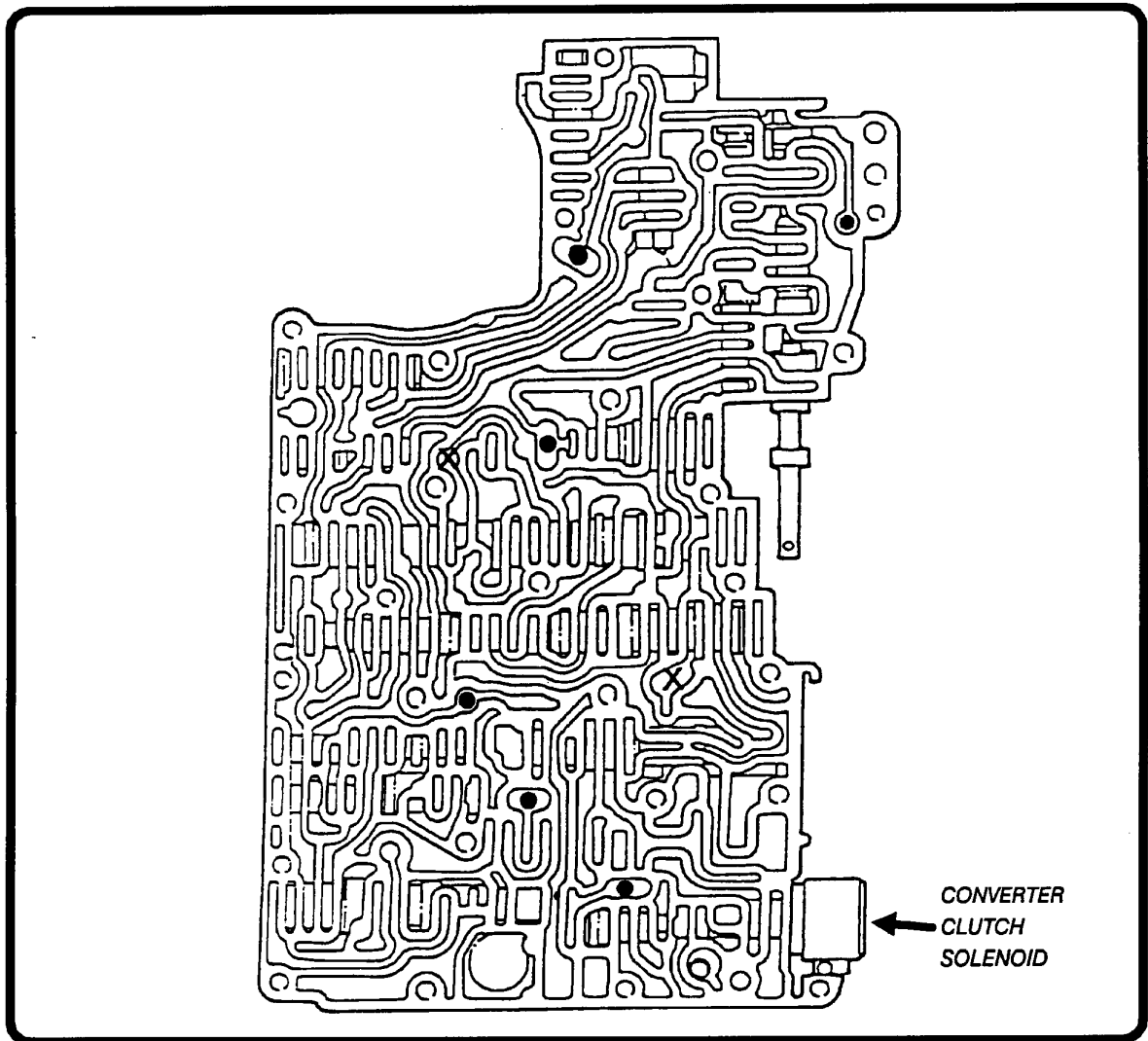

**LATE 1988-1990  
ELECTRONIC 3-4 SHIFT CHECKBALL LOCATION**

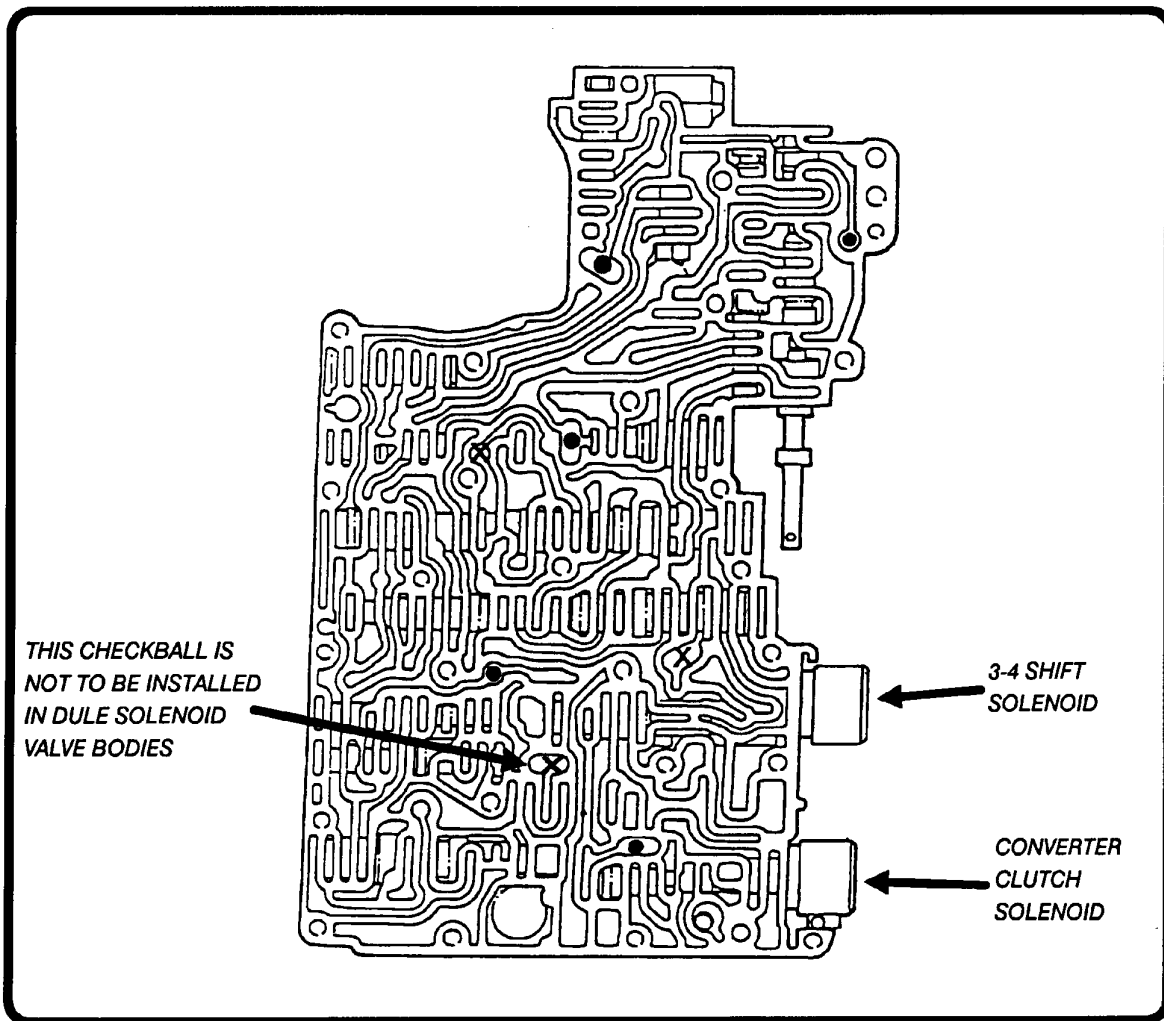

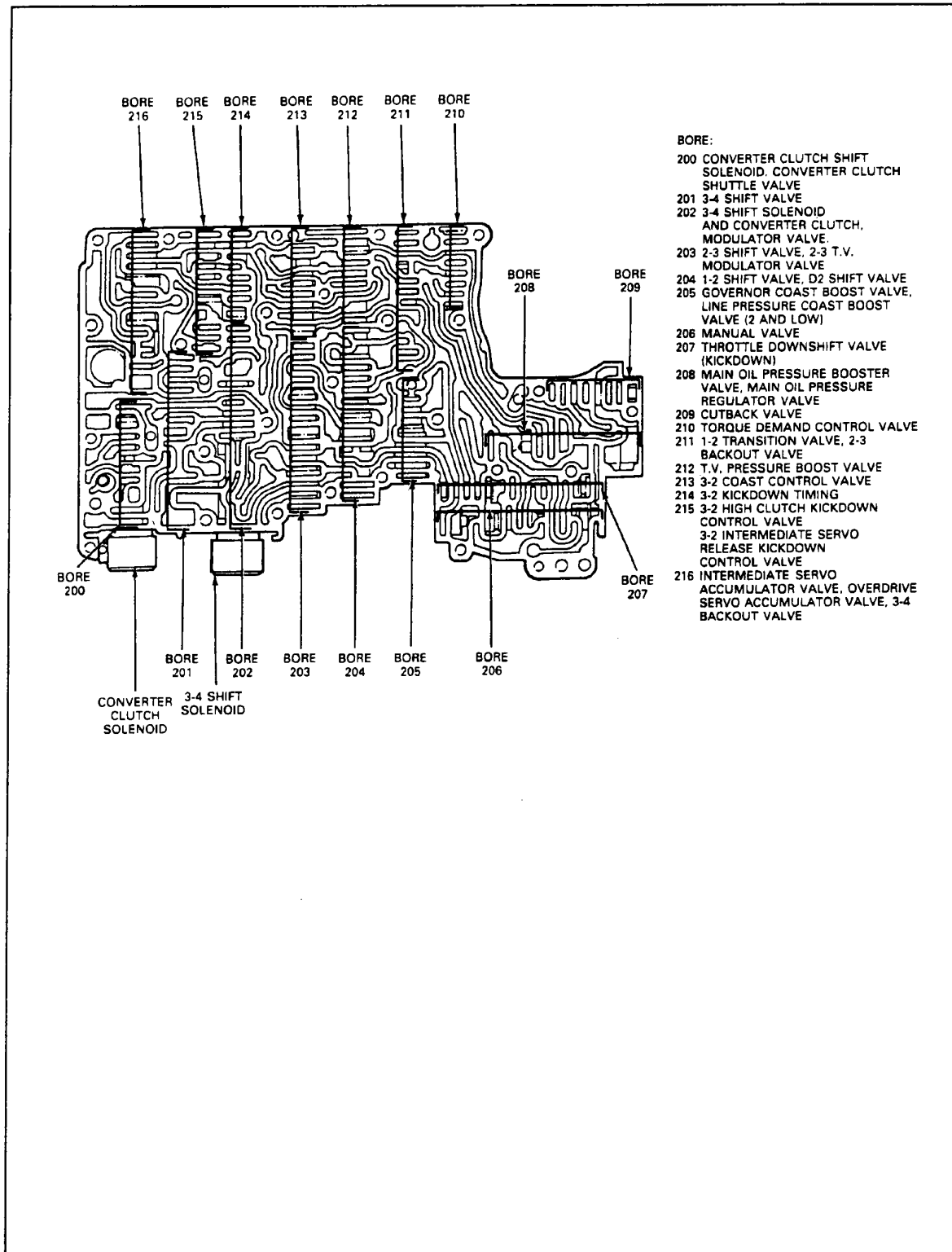

## Bore 200

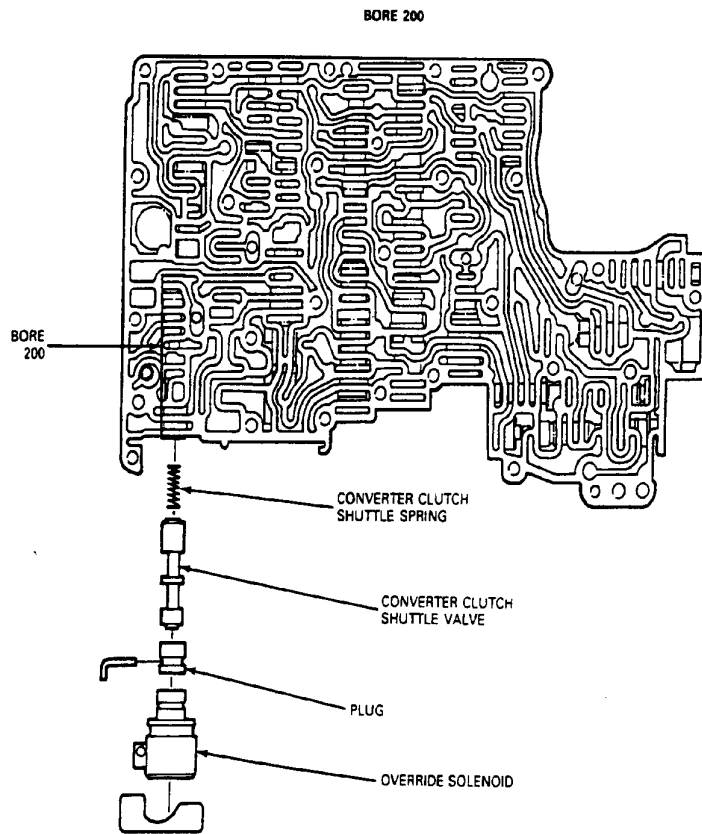



Bore 201

BORE 201

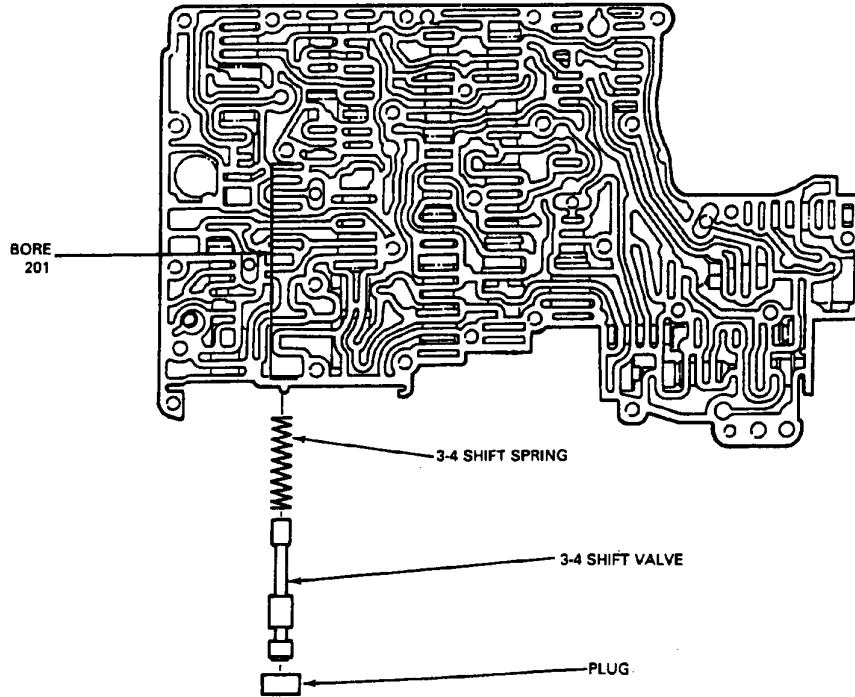

**Bore 202**

BORE 202

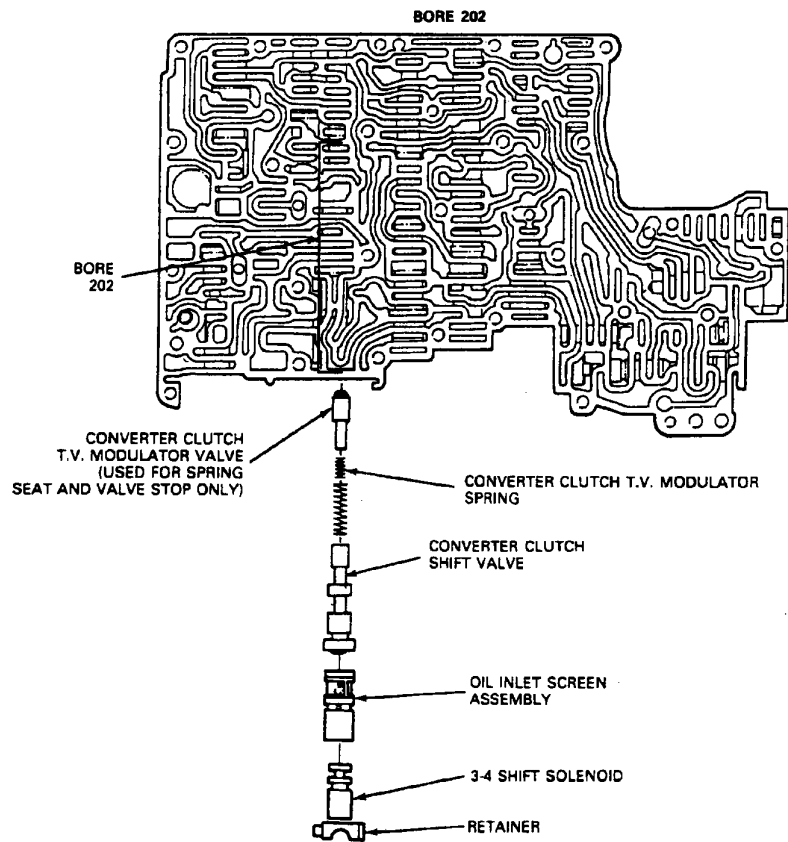

## Bore 203

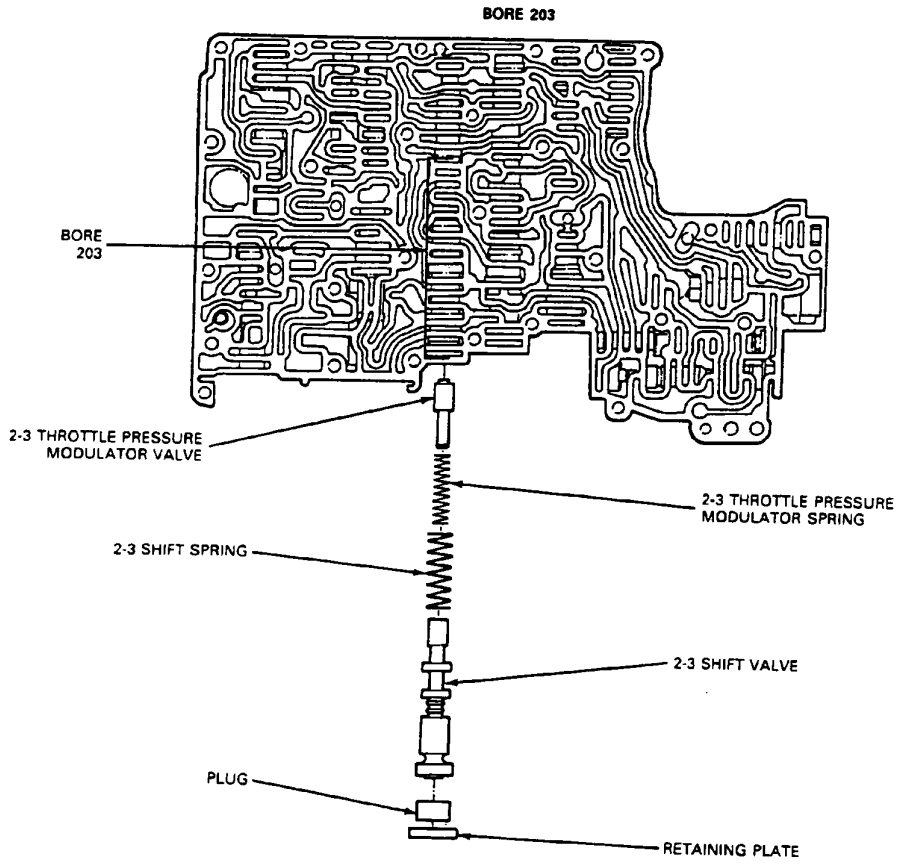

## Bore 204

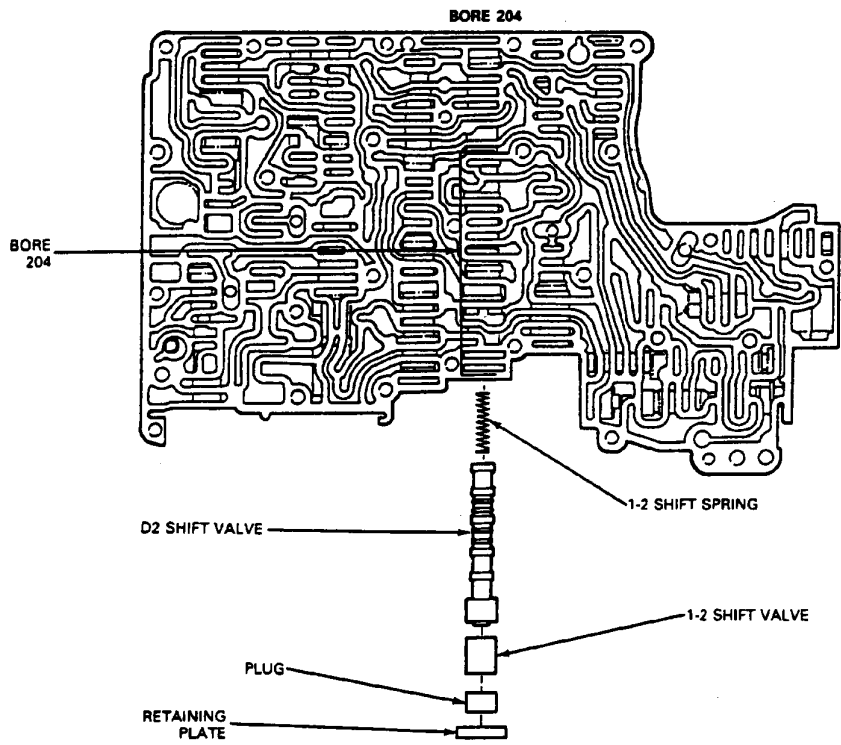

## Bore 205

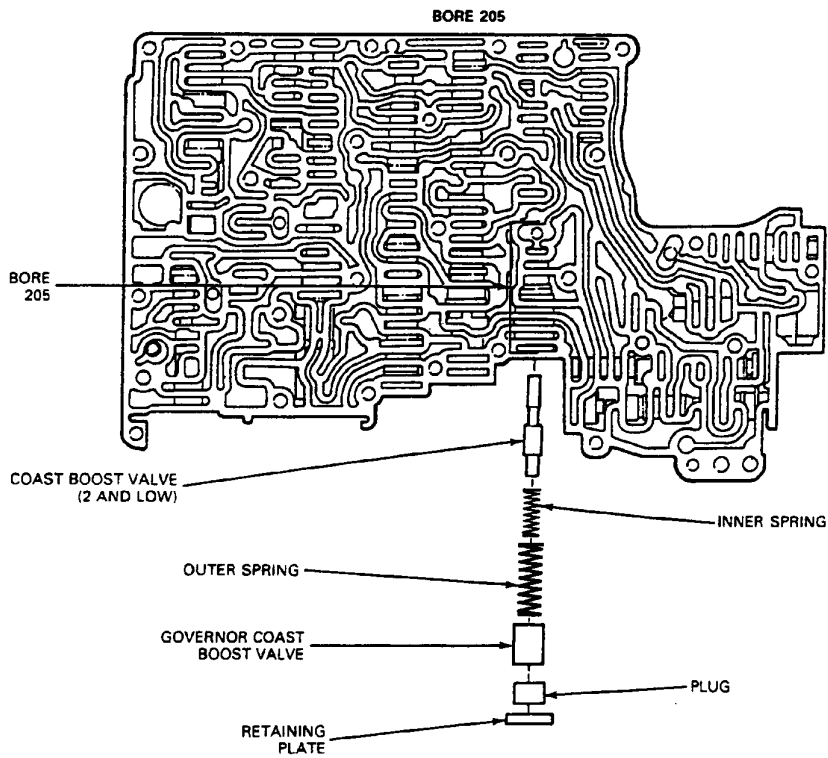

## Bore 206

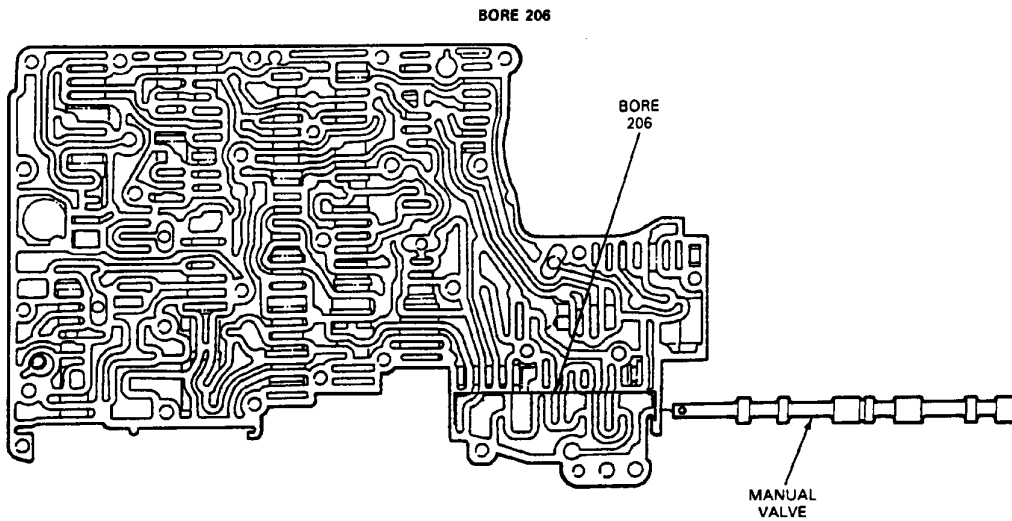

## Bore 207

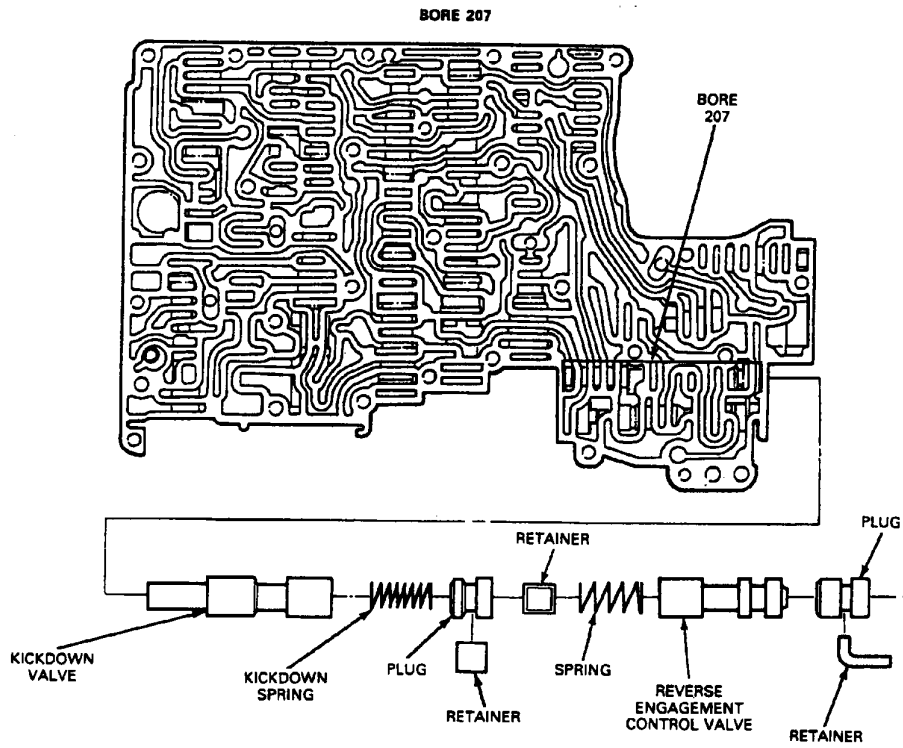

## Bore 208

BOOSTER 208

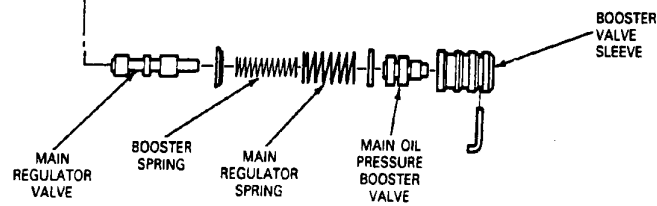
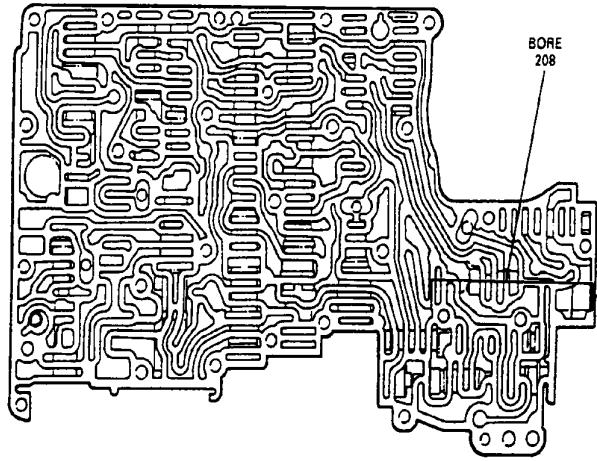

## Bore 209

BORE 209

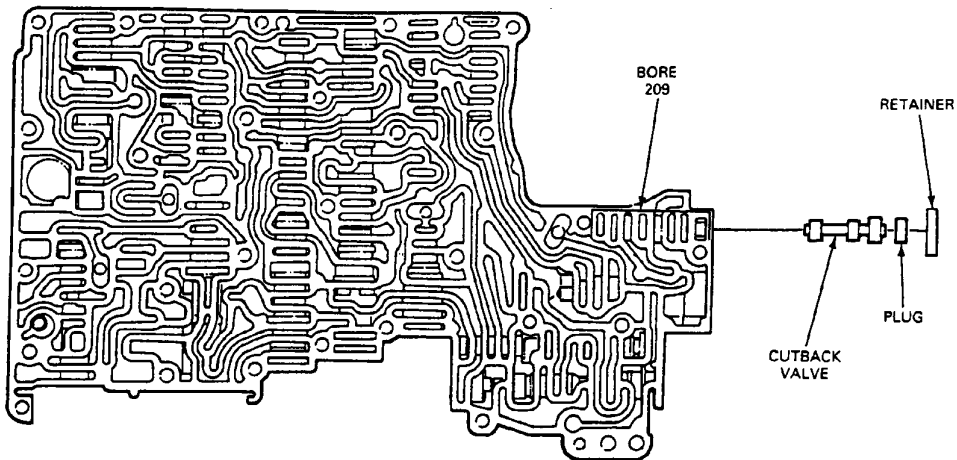

## Bore 210

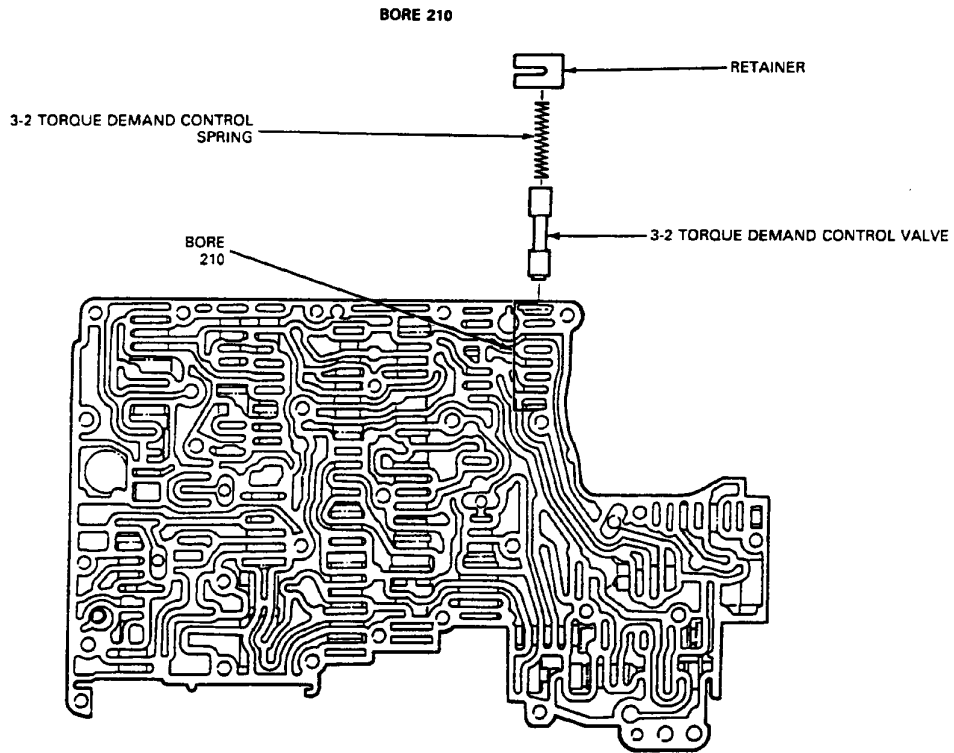



## Bore 211

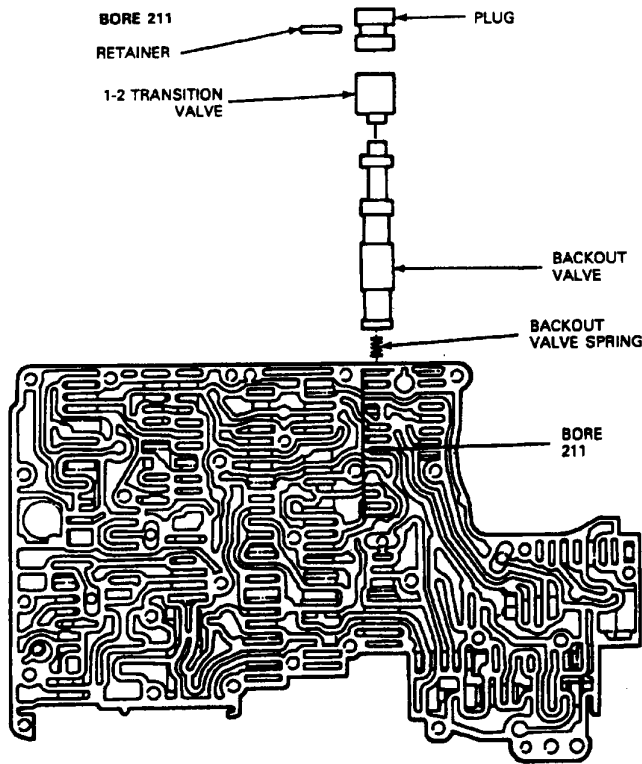

**Bore 212**

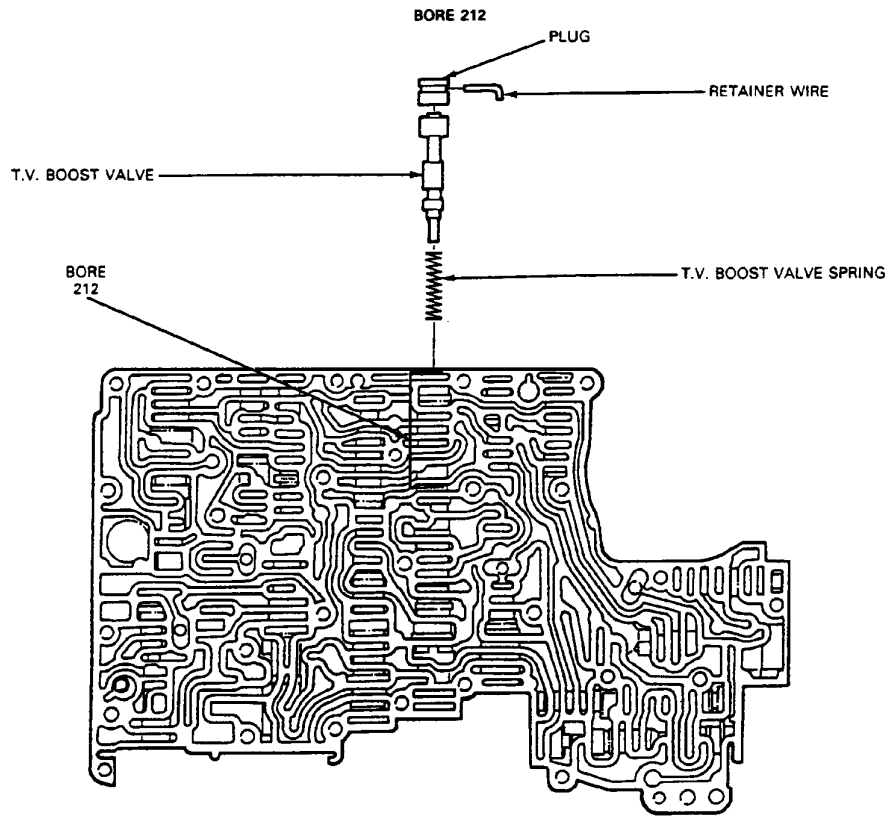

## Bore 213

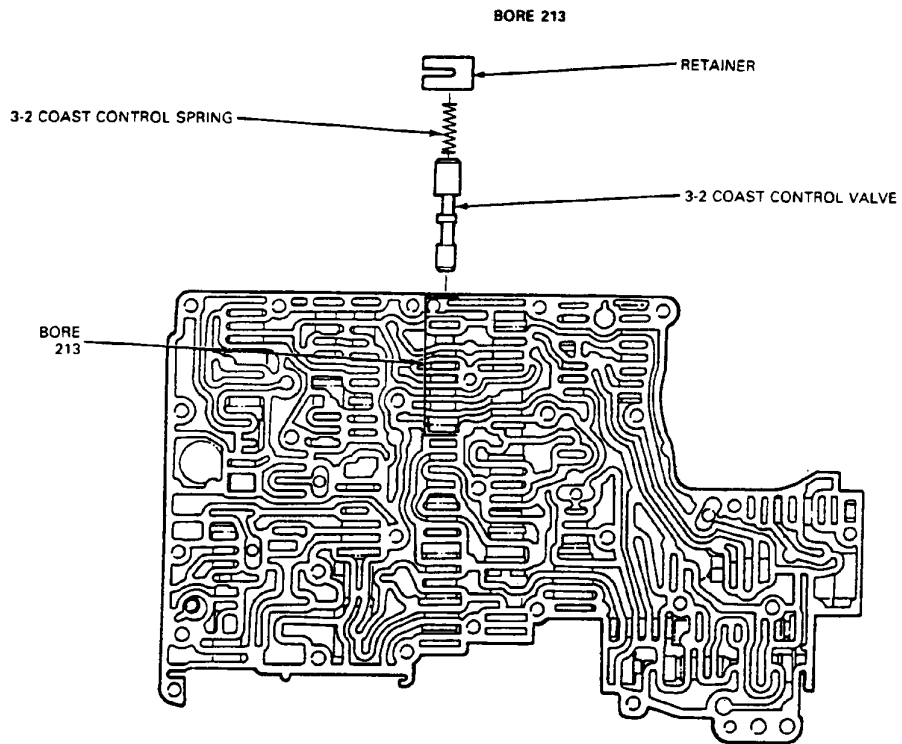

## Bore 214

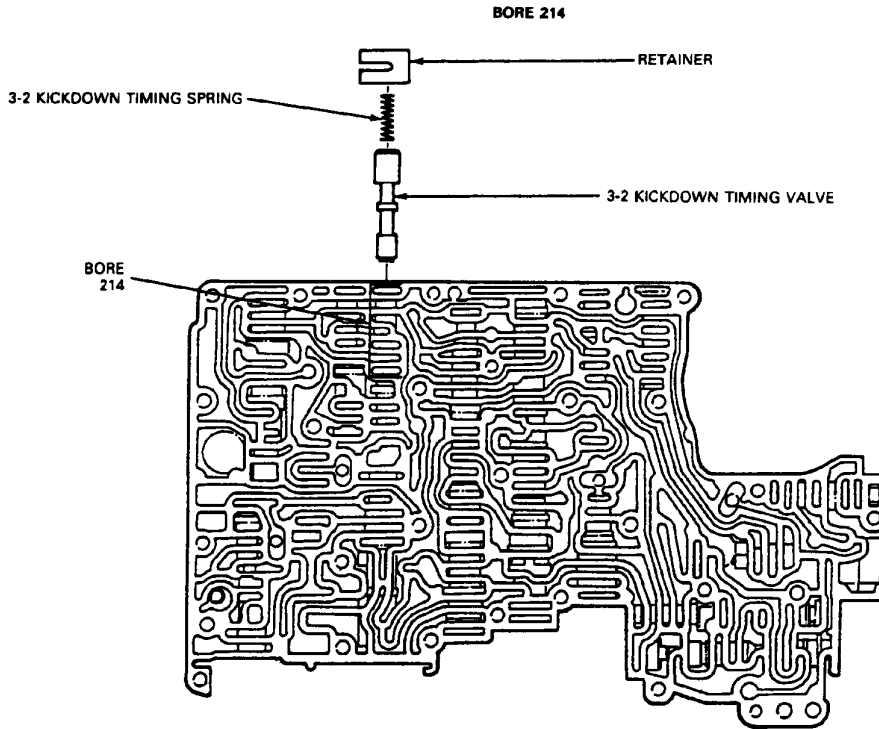

## Bore 215

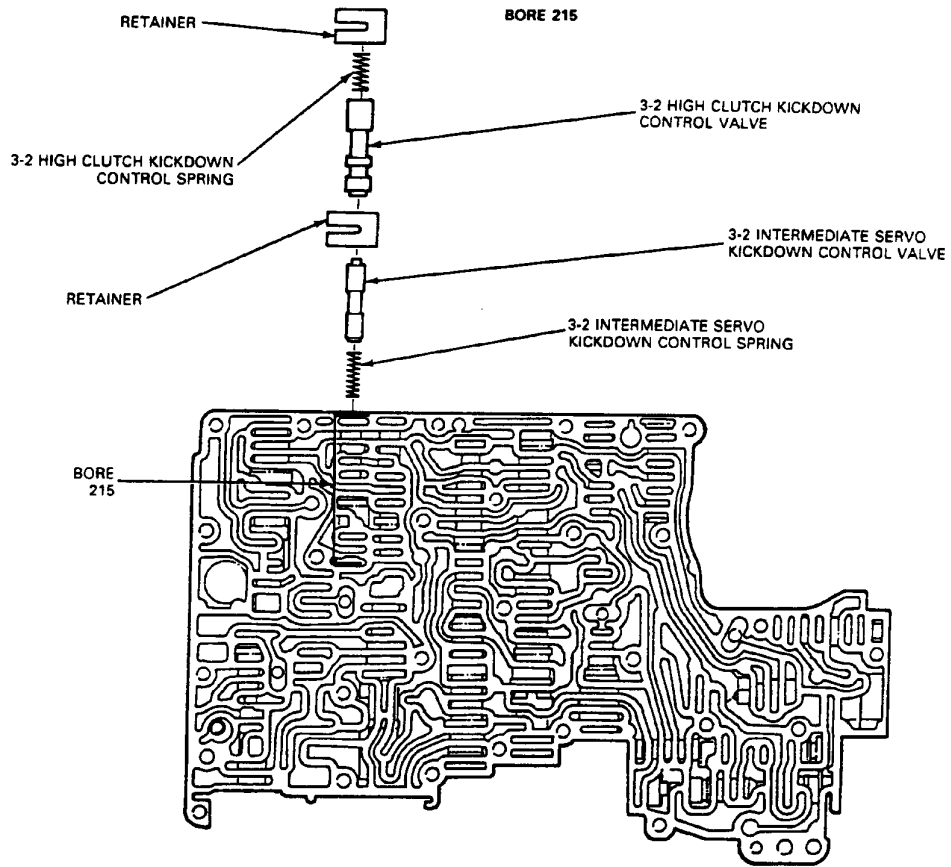

## Bore 216

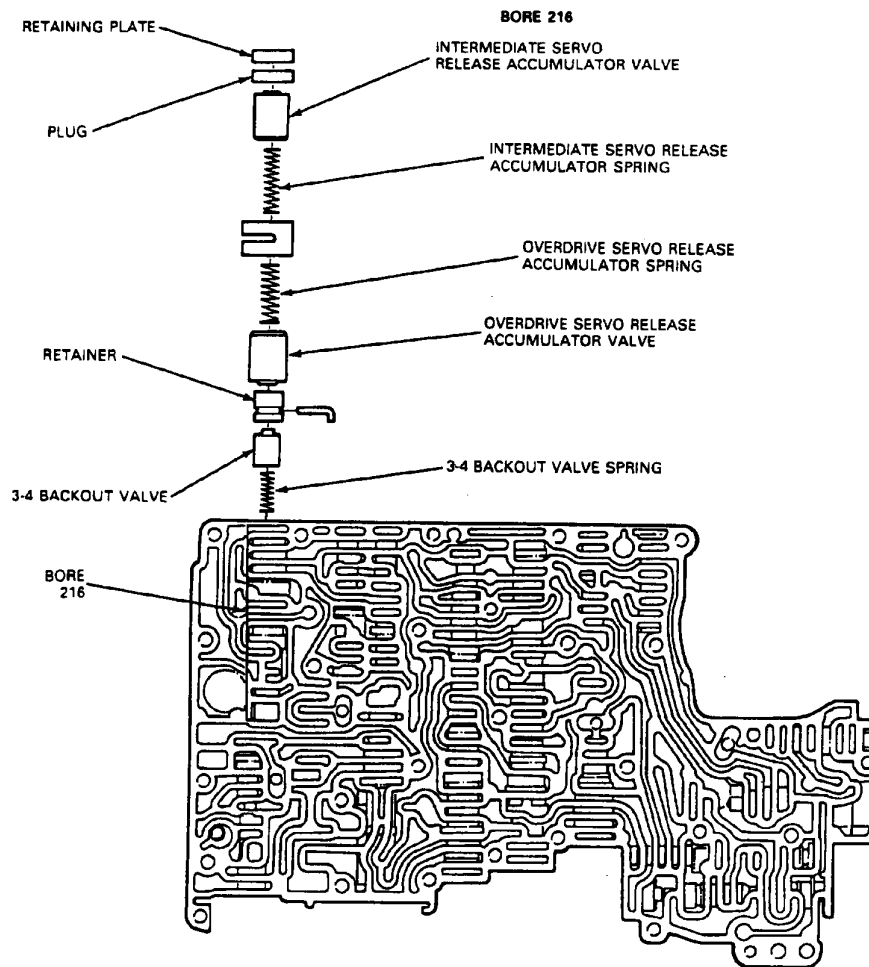

## Reverse-High Clutch

### Disassembly

1. Remove the pressure plate retaining ring. Remove the plate pack.
2. Inspect steel clutch plates and clutch lining plates for wear, damage or effects of overheating.
3. Replace the entire set if necessary.
4. If new plates are to be used, immerse them in transmission fluid for 30 minutes before assembly.

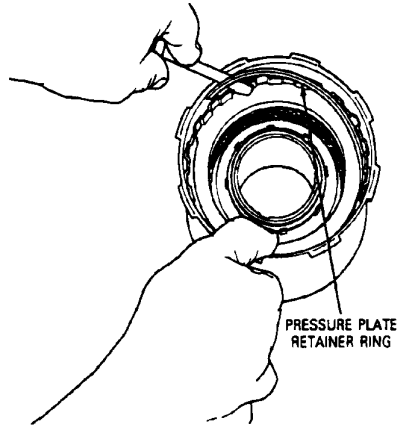

5. Compress the compression springs using Clutch Spring Compressor T65L-77515-A or equivalent. Remove retaining ring and carefully release pressure on the spring.
6. Remove the spring and compression spring retainer.

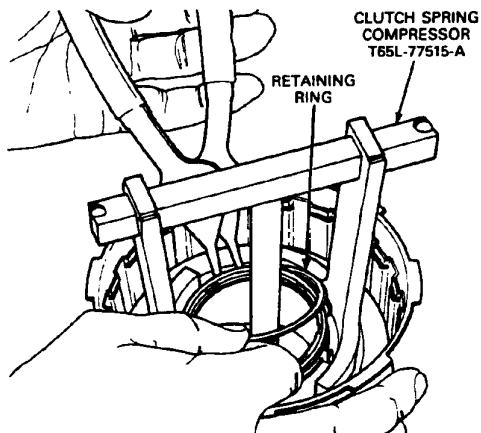

7. The piston is removed by air pressure as shown. Use finger to close off opposite hole.
8. Apply air pressure to blow out clutch piston.  
**CAUTION: Do not exceed 137 kPa (20 psi).**

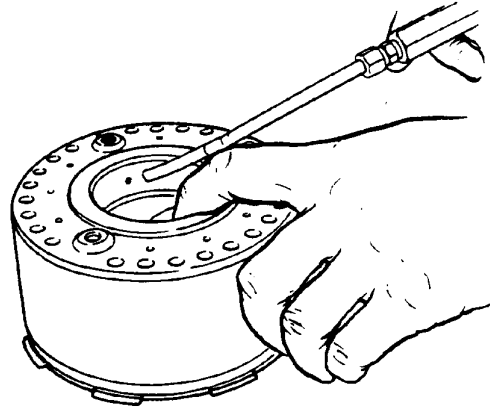

### Assembly

1. Install new seal rings on clutch piston.
2. Carefully install clutch piston into clutch body.
3. Install compression spring and spring retainer.
4. Compress springs using Clutch Spring Compressor T65L-77515-A or equivalent. Install the retaining ring.
5. Release load on the springs and remove tool.

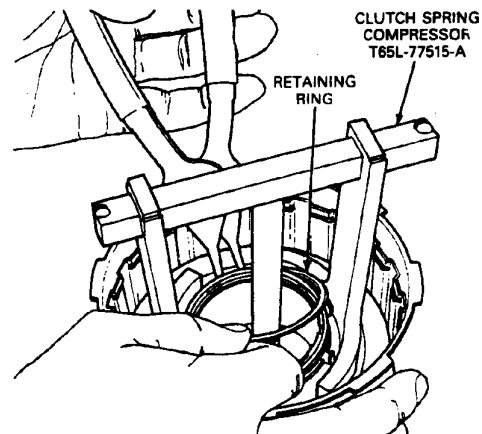

6. Install clutch plates beginning with a steel plate, then a friction plate / steel plate alternately, then the pressure plate. Secure with the retaining ring.

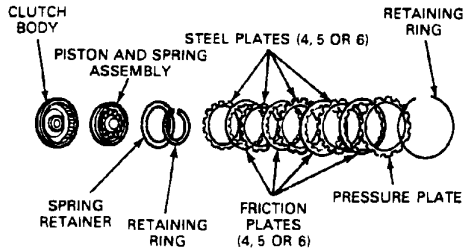

7. Use a feeler gauge to check the clearance between the retaining ring and pressure plate.
8. Push downward on the plates while making this check. The clearance should be to specification.
9. If clearance is not between 1.3 and 2.0mm (.051 and .079 inch), install a different suitable retaining ring.
10. Available retaining ring thicknesses are:
  - 1.37mm (.0539 inch)
  - 1.73mm (.0681 inch)
  - 2.08mm (.0819 inch)
  - 2.44mm (.0961 inch)

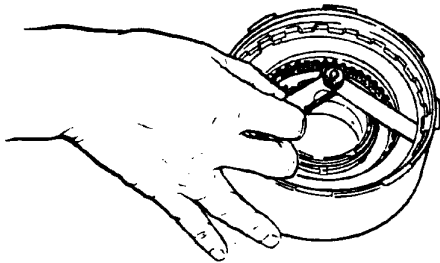

11. Perform the air test by blocking hole with finger to prevent air leakage.
12. Piston must apply when pressurized and release when air is removed.

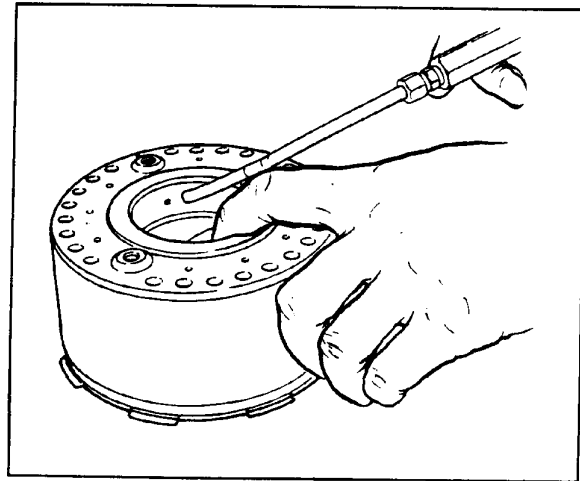

## Forward Clutch

### Disassembly

1. Disassembly of the forward clutch is the same as the disassembly of the reverse and high clutch that has been previously covered with one exception—removing the clutch piston.
2. The forward clutch piston is removed from the forward clutch cylinder with air pressure.
  - a. Install the center support on the forward clutch cylinder.

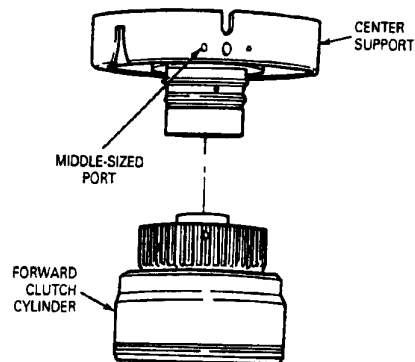



- b. Apply air pressure to the left (middle-sized) port in the center support as shown to force the piston assembly from the forward clutch cylinder.

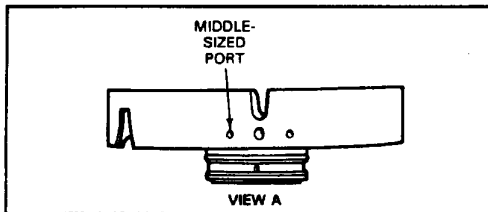
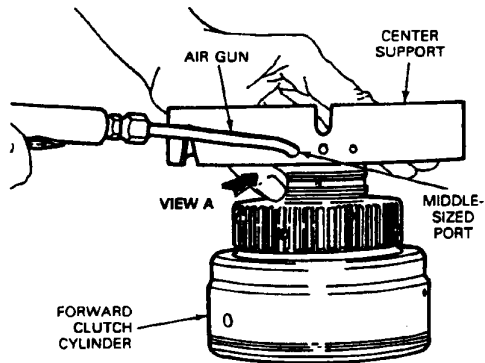

### Assembly

1. Reassembly of the forward clutch is the same as previously covered for the reverse and high clutch with the exception of the following:
  - A rubber forward clutch cushion spring between piston and steel plate.
  - Number of clutch plates: five steel and five friction.
2. Install clutch plates beginning with a steel plate, then alternate friction, steel, friction and so on. Install pressure plate and retaining ring.
3. Use a feeler gauge to check clearance between the retaining ring and pressure plate.
4. Push downward on the plates while making this check. The clearance should be to specification.
5. If clearance is not between 1.4 and 2.1mm (.055 and .083 inch), install a different suitable retaining ring.
6. Available retaining ring thicknesses are:
  - 1.37mm (.0539 inch)
  - 1.73mm (.0681 inch)
  - 2.08mm (.0819 inch)

2.44mm (.0961 inch)

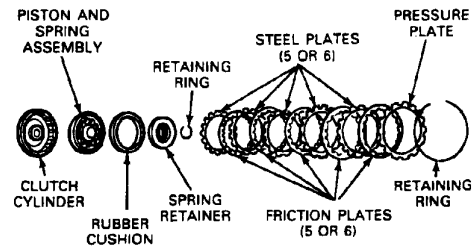

7. Perform the air test by installing the center support on the forward clutch cylinder. Apply air pressure to the left (middle-sized) port, as shown, to check piston application.
8. Piston must apply when pressurized and release when air is removed.

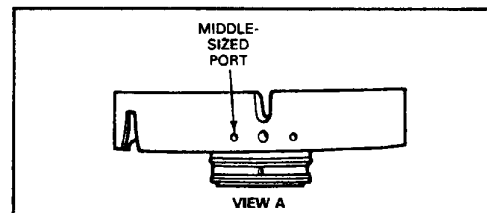
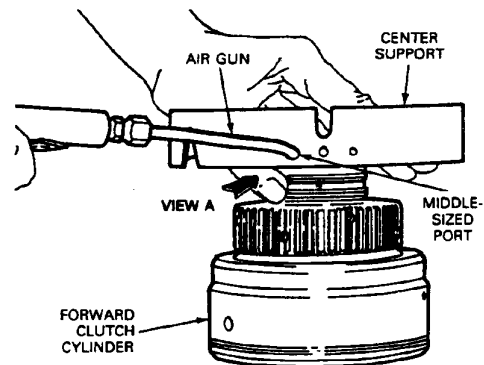

### Overdrive Clutch

#### Disassembly

1. Disassembly of the overdrive clutch is the same as disassembly of the reverse and high clutch with the exception of removing the clutch piston.

- The piston is removed by air pressure as shown. Use finger to close off air leak.

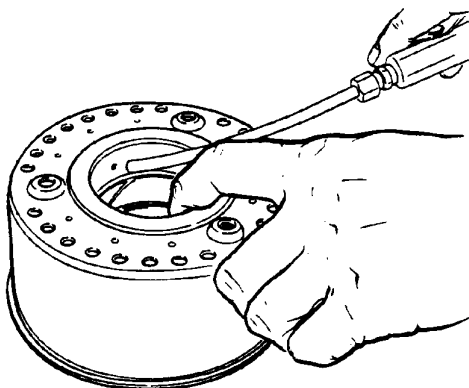

### Assembly

- Reassembly of the overdrive clutch is the same as previously covered for the reverse and high clutch with the exception of the following:
  - Place return springs around the assembly in groups of three.
  - Number of clutch plates: three steel and three friction.

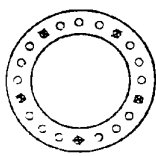

DO NOT PLACE RETURN SPRINGS AT X LOCATIONS

- Install clutch plates beginning with a steel plate, then alternate friction, steel, friction. Then, install the pressure plate and retaining clip.
- Use a feeler gauge to check clearance between the retaining ring and pressure plate.
- Push downward on the plates while making this check. The clearance should be to specification.
- If clearance is not between 1.4 and 2.1mm (.055 and .083 inch), install a different suitable retaining ring.

- Available retaining ring thicknesses are:

- 1.37mm (.0539 inch)
- 1.73mm (.0681 inch)
- 2.08mm (.0819 inch)
- 2.44mm (.0961 inch)

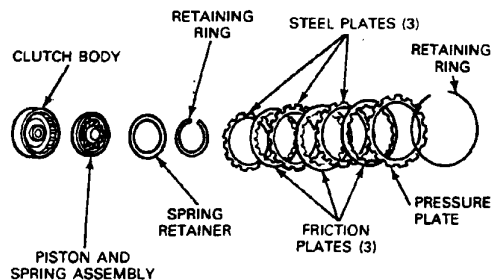

- Perform the air test by blocking the hole with a finger to prevent air leakage.
- Piston must apply when pressurized and release when air is removed.

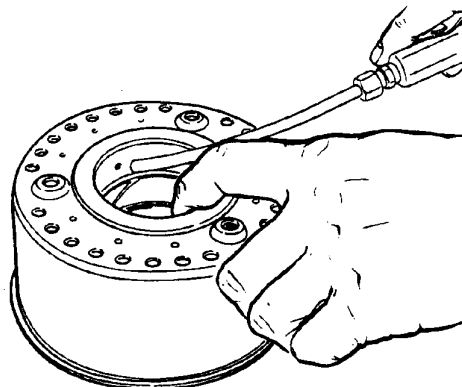

### Governor

#### Disassembly and Assembly

- Remove governor body to oil collector body attaching bolts.

**NOTE:** When the governor body attaching bolts are removed governor components are no longer retained in position to the governor body. Care must be taken not to drop the governor body and components when the attaching bolts are removed.

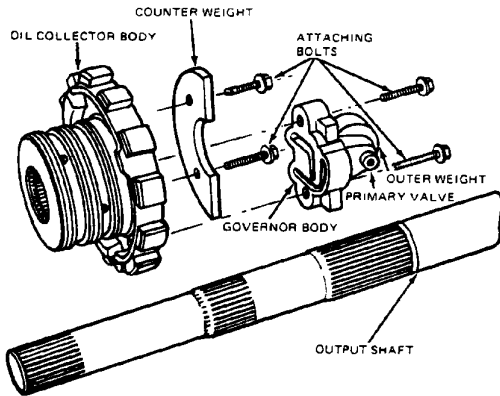

2. Remove governor components from the governor body.
3. Remove the counterweight.
4. Clean all parts. Replace parts that are worn or damaged.
5. Assemble the outer weight spring and primary valve in the governor body.
6. Assemble governor body and counterweight to the oil collector body.

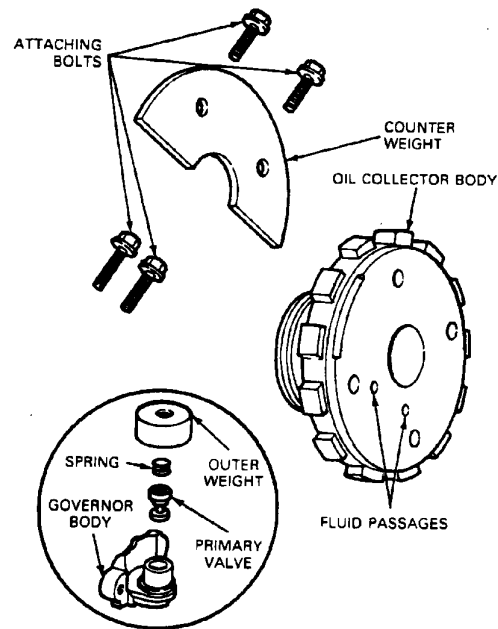

### Forward Geartrain Assembly

1. Assemble the forward clutch to the reverse and high clutch, positioning No. 5 (70428) thrust washer between them.
2. Assemble the forward planet gear carrier to the internal gear, with needle bearing thrust washer No. 7 (7F374) in between them.
3. On vehicles with 4.0L engines, position the No. 6 thrust bearing assembly on the gear carrier.  
**NOTE:** To prevent damage to the bearing needle cage, it must be installed as shown.
4. On 2.3L, 2.9L and 3.0L vehicles, position No. 6 integral thrust washer (7A045) on forward planet carrier hub.
5. Install the front planet assembly into the forward clutch.
6. Position needle bearing washer into forward planet gear carrier. Install clutch hub and sun gear.

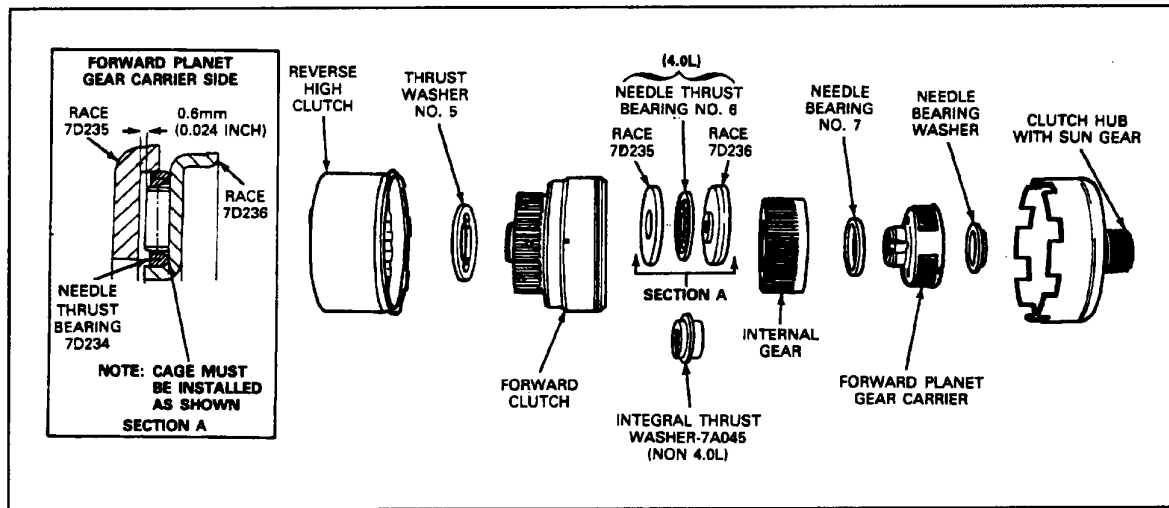

### One-Way Clutch

#### Disassembly and Assembly

NOTE: 4.0L applications use a sprag type one-way clutch that is not to be disassembled.

1. Remove the snap ring using a screwdriver.
2. Lift out the cage with the springs and bearing rollers as a unit.

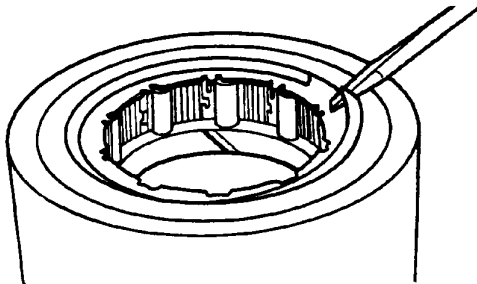

3. Install the cage with springs.

4. Insert bearing rollers one by one, using a suitable screwdriver and install snap ring.

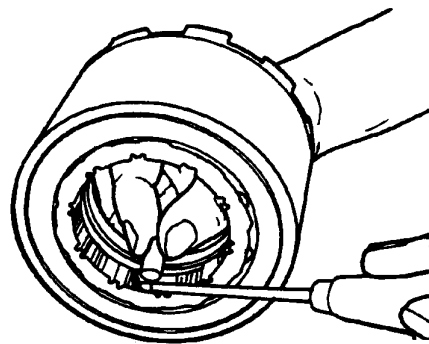



# Technical Service Information

## 1989 LINE PRESSURE SPECIFICATIONS

Trans.	Transmission Model/Application	Range	Idle		
			15" & Above	10"	WOT Stall Thru Detent
A4LD	2.3L TPH Ranger	D, D, 2, 1 R P, N	57-109 67-151 57-109	114-134 157-177	205-235 278-314
A4LD	2.9/3.0L Ranger/Br II/Aerostar	D, D, 2, 1 R P, N	57-78 67-105 57-78	114-134 157-177	205-235 282-316
A4LD	2.3L Mustang	D, D, 2, 1 R P, N	57-67 67-77 57-67	90-110 124-144	180-210 247-280

### A4LD TORQUE SPECIFICATIONS

Description	N-m	Ft-Lbs
Transmission to Engine	38.0-51.5	28-38
Converter Housing Lower Cover to Converter Housing	16.3-21.7	12-16
Converter Housing Access Cover (at Oil Pan on 2.3L)	2.5-3.6	*22-32
Converter Housing and Pump to Case	36.6-52.9	27-39
Oil Pump to Converter Housing	22-28	16-21
Center Support (O/D) to Case	9-13	*80-115
Extension Housing to Case	36.6-52.9	27-39
Oil Pan to Case	11-13.5	8-10
Main Control to Case	8.0-11.0	*71-97
Separator Plate to Valve Body	6.1-8.1	*54-72
Detent Spring to Valve Body	9.0-12.1	*80-107

Reverse Servo to Case	9.0-13.0	*80-115
Vacuum Diaphragm Retainer Clip to Case	9.0-12.0	*80-106
Governor Assembly to Oil Collector Body	9.5-13.6	*84-120
Outer Downshift Lever to Inner Lever Shaft Nut	9.5-15.0	7-11
Manual Lever Nut	40.7-54.2	30-40
Overdrive Band Adjusting Screw Locknut to Case	47.5-61.0	35-45
Intermediate Band Adjusting Screw Locknut to Case	47.5-61.0	35-45
Converter to Flywheel Attaching Nut	27.1-46.1	20-34
Cooler Line to Case Connector	24.4-31.2	18-23
Cooler Line to Connector — Tube Nut (5/16 Inch). (Torque Tube Nuts to Spec. While Holding the Transmission Fitting.)	16.3-24.4	12-18
Pressure Plug to Case	9.5-14.9	7-11

### AUTOMATIC TRANSMISSION REFILL CAPACITY A4LD\*\*

\*In-Lbs

Vehicle	Engine	Approximate Refill Capacity*	
		U.S. Quarts	Liters
Aerostar	3.0L/4.0L	9.7	9.2
Ranger 4x2	2.3L, 2.9L	9.7	9.2
Bronco II 4x2	2.9L	9.7	9.2
Ranger 4x4, Bronco II 4x4, Aerostar E4WD	2.9L/4.0L	10.0	9.5

\*Approximate dry capacity, includes cooler and lines. Fluid level indicator should be used to determine actual fluid requirements and fluid specifications. Check level at normal operating temperature. **DO NOT OVERFILL.**

If it is necessary to add or replace fluids, use only fluids which have been certified by the supplier as meeting one of the Ford Motor Company specifications shown below:

\*\*A4LD transmission — Use fluids meeting specification Motorcraft MERCON® WSP-M2C185-A.

### STALL SPEED SPECIFICATIONS

Vehicle Application	Engine Disp.	Transmission Type	Converter Size	Stall Speed RPM	
				Min.	Max.
Aerostar	3.0L	A4LD	10-1/4 Inches	2720	3165
Aerostar	4.0L	A4LD	10-1/4 Inches		
Ranger	4.0L	A4LD	10-1/4 Inches		
Ranger, Bronco II	2.9L	A4LD	10-1/4 Inches	2781	3268
	2.3L	A4LD	10-1/4 Inches	2437	2833



# Technical Service Information

## SELECTIVE THRUST WASHERS

Location	Transmission Front End Play	Part Number	Thickness mm (in.)	Number Stamped On Washer
No. 1 Thrust Washer Front Pump Support	0.18-0.64 mm (0.007-0.025 in.) without gasket	89DT-7D014-HA	1.2 (0.047)	A
		89DT-7D014-AA	1.4 (0.055)	1
		89DT-7D014-BA	1.6 (0.063)	2
		89DT-7D014-CA	1.7 (0.067)	3
		89DT-7D014-DA	1.8 (0.071)	4
		89DT-7D014-EA	1.9 (0.075)	5
		89DT-7D014-FA	2.0 (0.079)	6
		89DT-7D014-GA	2.1 (0.083)	7
		89DT-7D014-MA	2.2 (0.087)	B
		89DT-7D014-JA	2.4 (0.094)	C
89DT-7D014-KA	2.6 (0.102)	D		
89DT-7D014-LA	2.8 (0.110)	E		
No. 4 Thrust Washer O/D Center Support	Transmission Rear End Play .30-.54 mm (.012-.022 in.)			

## CLUTCH PLATES

Engine	Forward Clutch			Reverse/High Clutch		
	Steel	Friction	Clearance	Steel	Friction	Clearance
2.3L EFI, 2.3L	5	5	0.055-0.083	5	5	0.051-0.079
2.9L EFI	5	5	0.055-0.083	5	5	0.051-0.079
3.0L EFI	5	5	0.055-0.083	5	5	0.051-0.079
4.0L EFI	6	6	0.055-0.083	6	6	0.051-0.079

## CHECKS AND ADJUSTMENTS

Engine	Overdrive Clutch			Operation	Specification
	Steel	Friction	Clearance		
2.3L EFI 2.9L EFI	3	3	0.039-0.067	Remove and discard locknut. Install new locknut. Tighten adjusting screw to 10 ft-lb. Back off 2 turns for overdrive band (2.3L, 2.9L and 3.0L), or 3½ turns for 4.0L applications and 2 turns for intermediate band. Hold screw and tighten locknut.	Transmission End Play (Front) 0.18-0.64 mm (.007-.025 in.) Less Gasket
3.0L EFI	3	3	0.039-0.067		Transmission End Play (Rear) .30-.54 mm (.012-.022 in.)
4.0L EFI	3	3	0.039-0.067		Overdrive and Intermediate Band Adjustment

## VACUUM DIAPHRAGM ASSEMBLY SPECIFICATION

Transmission Type	Diaphragm Type	Diaphragm Part No.	Throttle Valve Rod		
			Part No. (7A380)	Length	Identification
A4LD	SAD	83DT-7A377-D2B/D1B	85GT-AA	No Selection	None
	HAD	83DT-7A377-A2B/A1B	85GT-AA		
	HAD	90DT-7A377-A3A	85GT-AA		

SAD — Single Area Diaphragm

HAD — High Altitude Diaphragm

## TORQUE CONVERTER END-PLAY

Transmission Model	Converter End-Play			
	New or Rebuilt Converter		Used Converter	
	mm	Inch	mm	Inch
A4LD	0.58 Max.	0.023 Max.	1.27 Max.	0.050 Max.

## SELECTIVE SNAP RINGS

Part Number	Overdrive And Reverse/High Clutch				Part Number	Forward Clutch			
	Thickness		Diameter			Thickness		Diameter	
	mm	Inches	mm	Inches		mm	Inches	mm	Inches
E 860126-S	1.37	.0539	130.1	5.122	E 860115-S	1.37	.0539	125.1	4.925
E 860127-S	1.73	.0681	130.1	5.122	E 860116-S	1.73	.0681	125.1	4.925
E 860128-S	2.08	.0819	130.1	5.122	E 860117-S	2.08	.0819	125.1	4.925
E 860129-S	2.44	.0961	130.1	5.122	E 860118-S	2.44	.0961	125.1	4.925

Automatic Transmission Service Group